

**CITY OF STURGEON BAY**  
**DRIVEWAY PERMIT**

**I HEREBY REQUEST A PERMIT FOR THE ITEMS SPECIFIED BELOW:**

Owner of Premises: \_\_\_\_\_

Phone No (\_\_\_\_) \_\_\_\_\_ - \_\_\_\_\_ Email: \_\_\_\_\_

Address or Legal Description: \_\_\_\_\_

\_\_\_\_\_

- CONSTRUCTION OF A DRIVEWAY IN ACCORDANCE WITH THE PROVISIONS OF CHAPTER 8 OF THE CITY OF STURGEON BAY MUNICIPAL CODE
- BREAK OUT \_\_\_\_\_ FEET OF CURB FOR DRIVEWAY PURPOSES
- CONSTRUCTION OF A DRIVEWAY ACROSS A CONCRETE SIDEWALK
- OTHER (Describe) \_\_\_\_\_

NOTE: See required DRIVEWAY DETAILS on page 2 of this form. If any existing City concrete sidewalk less than 6 inches thick will be crossed by a proposed new driveway it shall be removed and replaced with 6 inch thick concrete sidewalk.

I HEREBY CERTIFY THAT I AM FAMILIAR WITH, AND WILL CONFORM TO ALL THE REQUIREMENTS OF THE STATE CODE, AND CITY OF STURGEON BAY CODE COVERING THE WORK FOR WHICH, THIS PERMIT IS REQUESTED, AND THAT I WILL NOTIFY THE CITY ENGINEER WHEN SAID WORK IS READY FOR INSPECTION AS REQUIRED BY SAID CODE.

\_\_\_\_\_  
(Person making application)

\_\_\_\_\_  
Date of Application

\_\_\_\_\_  
City Engineer

\_\_\_\_\_  
Date of Approval

PERMIT # \_\_\_\_\_ HEREBY ISSUED FOR THE ABOVE DESCRIBED WORK, AND IS TO BE COMPLETED IN ACCORDANCE WITH STATE AND CITY CODES.

PERMIT ISSUED \_\_\_\_ / \_\_\_\_ / \_\_\_\_

THIS PERMIT EXPIRES: \_\_\_\_ / \_\_\_\_ / \_\_\_\_

FEE: **\$50.00** PAID: \_\_\_\_\_

# DRIVEWAY DETAILS

NO SCALE

## DRIVEWAY DETAIL

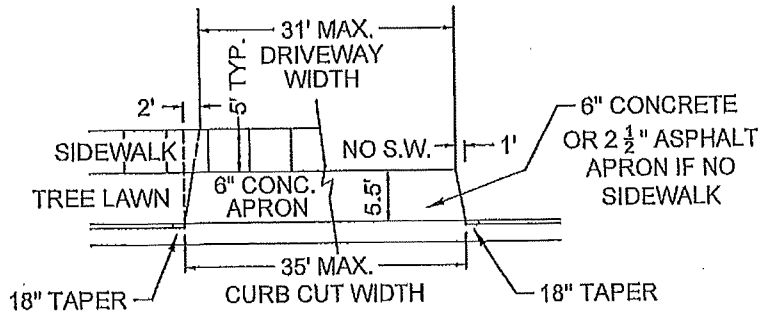

### ACCEPTABLE CURB CUT OPTIONS:

1. REPLACE ENTIRE CURB SECTION AND INSTALL 18" TAPERS
2. BACK-CUT & REMOVE CURB HEAD WITH PRECISION SAW MAINTAINING EXISTING CURB FLOW LINE AND CUTTING FRONT BEVELED 18" TAPERS

## SIDEWALK DETAIL

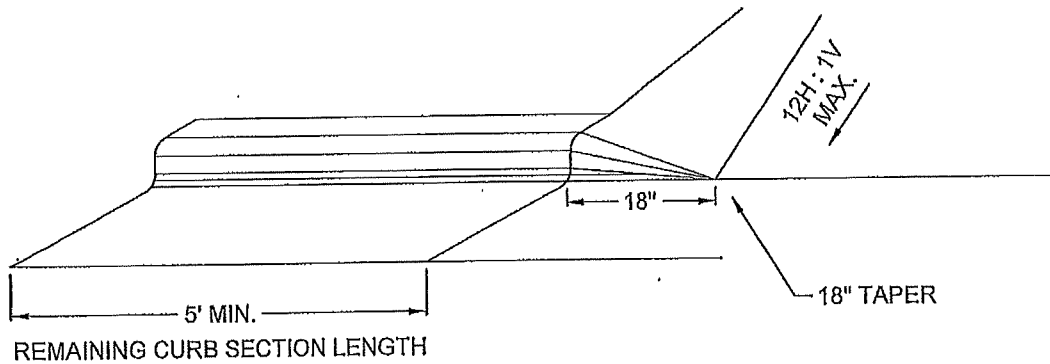
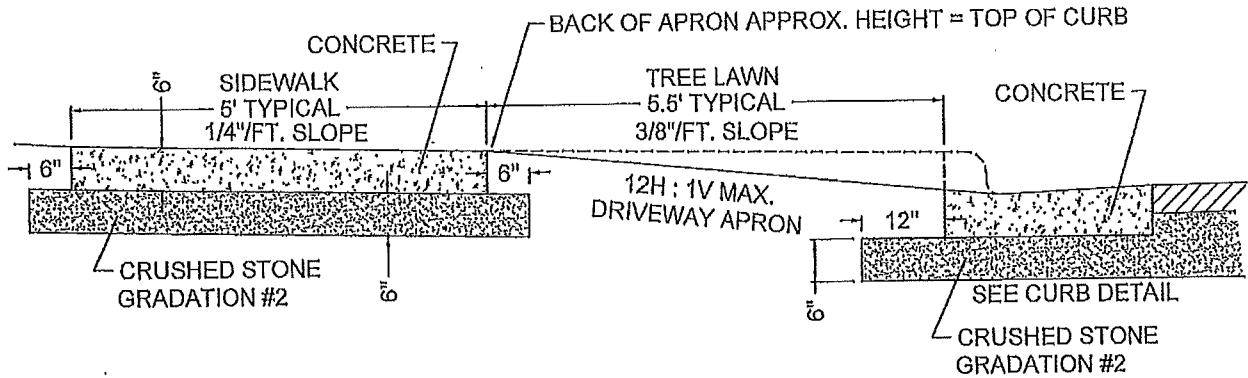

EXISTING STANDARD CURB DETAIL  
NO SCALE

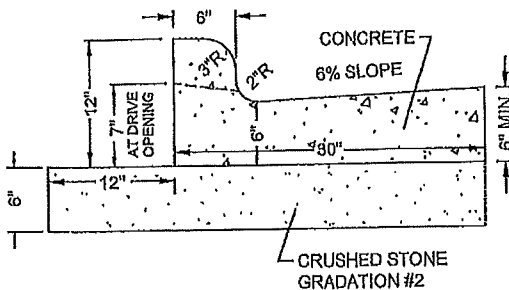

EXISTING OTHER CURB DETAIL  
NO SCALE

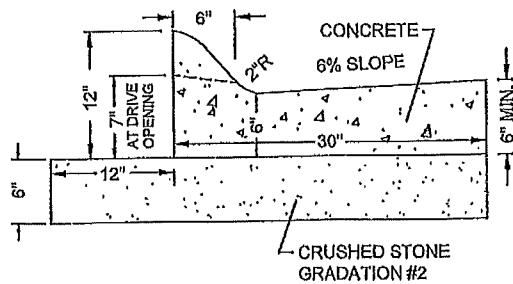

## STREETS AND SIDEWALKS

### 8.01 - Street, alley and sidewalk grades.

(1) *Establishment.* The grade of all streets, alleys and sidewalk shall be established and described by the common council and shall be recorded in the office of the clerk-treasurer. No street, alley or sidewalk shall be worked until the grade thereof is established.

(2) *Altering grade prohibited.* No person shall alter the grade of any street, alley, sidewalk or public ground or any part thereof unless authorized or instructed to do so by the common council.

### 8.02 - Construction and repair of sidewalks.

The provisions of § 66.615, Wis. Stats., are adopted by reference and made a part of this section as if fully set out.

### 8.03 - Construction of driveways.

(1) *Permit required.* No person shall construct any driveway that connects to or is within the city street right of way without first obtaining a permit for such construction from the city engineer.

(2) *Application for permit.* The application for such permit shall have attached to it a diagram or plat showing the dimensions of the lot, the location and width of the proposed driveway, the surface material of the driveway, the location of buildings or other improvements serviced by such driveway, the location of existing driveways on the lot or within 25 feet of the lot, and such other information as the city engineer shall require.

(3) *Construction Specifics.* Construction of driveways must be designed and constructed in a manner that it will not cause any damage to the City infrastructure nor create any hazard to the public.

(a) Precision curb cuts are required from the back side of the curb to the flow line with an 18 inch taper on each end, or curbing can be removed and replaced at the discretion of the city engineer.

(b) If the proposed driveway crosses a city sidewalk, a six inch thick concrete apron is required between the curb and sidewalk. In addition, any portion of the sidewalk that is less than 6 inches thick that is crossed by the driveway shall be removed and replaced with a 6 inch thick sidewalk.

(c) If the proposed driveway does not cross a city sidewalk, a five foot, six inch (5' 6") wide driveway apron is required which shall consist of six inch thick concrete or 2.5 inch thick asphalt. The apron shall be graded to match the top of the curbing at the furthest point from the curbing. Gravel aprons are not permitted along city streets with curbing.

(d) If the proposed driveway is on a street that does not have curbing, only an asphalt or gravel surface is permitted within the city right of way.

(4) *Discretion of city engineer.* In reviewing applications for driveway permits, the city engineer shall consider factors including site distance along curves and hills, steep grades where the driveway meets the street, impacts on storm water flow, coordination with adjacent driveways, and other traffic safety factors. Where the location of a proposed driveway unnecessarily creates a traffic hazard or storm water problem, the city engineer may require such proposed driveway to be relocated to some other portion of the premises or place conditions needed to prevent such traffic hazard or storm water problem.

(5) *Limitation on width.* In no event shall the city engineer issue a driveway permit for any driveway with a greater proposed width than 35 feet at the curb. In granting permits for driveways leading to places of business, the city engineer shall restrict the width of driveways as much as possible consistent with the business needs of the occupant of the premises.

(6) *Safety zone required.* Where a place of business is serviced by two or more driveways leading from the same street, the driveways shall be constructed at least eight feet apart at the sidewalk; the space between the two driveways shall be known as a "safety zone," and when the lot side of the safety zone adjoins a loading platform or driveway used for vehicular travel it shall be separated from the loading platform or driveway by a curb which shall be constructed on the lot line; all driveways shall be constructed at the same level as the sidewalks which they cross.

(7) *Distance from crosswalk or building.* No driveway shall hereafter be constructed within four feet of the regular street crosswalk at intersections or within four feet of a building where it abuts the sidewalk.

(8) *Setback for driveways serving large parking areas.* An access driveway that serves a parking area for 20 or more vehicles shall be located at least ten feet from any adjoining lot containing a residential principal use or from any adjoining vacant lot within a residential zoning district.

(9) *Setbacks from side and rear lot lines.* Any driveways serving a single-family dwelling or two-family dwelling shall be set back from side and rear lot lines as follows:

(a) The required setback shall be based upon the lot width of the lot upon which it is located as indicated by the following table:

Driveway Setback From Side & Rear Lot Lines	
Lot Width (ft.)	Minimum Setback (ft.)
<70	1
≥70 and ≤85	3
>85	5

(b) *Exemptions.* Shared driveways serving more than one lot shall be exempt from the required setback provided all affected property owners submit a written agreement and execute a recorded easement for the shared driveway.