



**SPECIAL CITY COUNCIL WORKSESSION  
RICHFIELD MUNICIPAL CENTER, BARTHOLOMEW ROOM  
MARCH 27, 2018  
5:45 PM**

Call to order

1. T-21 Tobacco Initiative
2. Human Rights Commission presentation of demographics of the City Advisory Commissions.

Adjournment

**Auxiliary aids for individuals with disabilities are available upon request. Requests must be made at least 96 hours in advance to the City Clerk at 612-861-9738.**

**CITY OF RICHFIELD, MINNESOTA**  
Office of City Manager

March 22, 2018

Council Memorandum No. 21

The Honorable Mayor  
and  
Members of the City Council

Subject: March 27, 2018 City Council Work Session

Council Members:

The following items will be discussed at the upcoming City Council work session:

**T-21 Tobacco Initiative**

Tobacco 21, a nationwide movement to increase the minimum legal age to purchase tobacco products to age 21 will be presented by the Richfield Advisory Board of Health. Local communities across Minnesota, including Bloomington, Edina, St. Louis Park, Plymouth and North Mankato have all seen successful passage of Tobacco 21 policies. The Richfield Advisory Board of Health is looking for support and direction on next steps to work toward a successful policy for Richfield.

**Human Rights Commission Demographics of City Advisory Commissions**

Human Rights Commission (HRC) members will present the results of their annual poll on the City Advisory Commissions demographics comparison. The HRC is attempting to create more diversity among all the commissions.

Respectfully submitted,

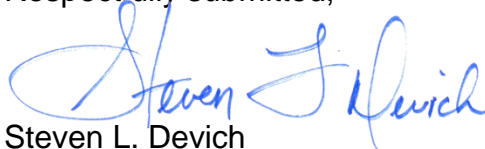

Steven L. Devich  
City Manager

SLD:ja/jjv

Email: Assistant City Manager  
Department Directors



**REGULAR CITY COUNCIL MEETING  
RICHFIELD MUNICIPAL CENTER, COUNCIL CHAMBERS  
MARCH 27, 2018  
7:00 PM**

**INTRODUCTORY PROCEEDINGS**

Call to order

Open forum (15 minutes maximum)

***Each speaker is to keep their comment period to three minutes to allow sufficient time for others. Comments are to be an opportunity to address the Council on items not on the agenda. Individuals who wish to address the Council must have registered prior to the meeting.***

Pledge of Allegiance

Approval of the minutes of the regular City Council meeting of March 13, 2018.

**PRESENTATIONS**

1. Presentation by Hennepin County Sheriff Richard W. Stanek

**COUNCIL DISCUSSION**

2. Hats Off to Hometown Hits

**AGENDA APPROVAL**

3. Approval of the Agenda
4. **Consent Calendar contains several separate items, which are acted upon by the City Council in one motion. Once the Consent Calendar has been approved, the individual items and recommended actions have also been approved. No further Council action on these items is necessary. However, any Council Member may request that an item be removed from the Consent Calendar and placed on the regular agenda for Council discussion and action. All items listed on the Consent Calendar are recommended for approval.**
  - A. Consideration of the approval of a bid tabulation and award of contract to Bituminous Roadways Inc. for the 2018 Mill and Overlay project in the amount \$1,573,102, and authorization of the City Manager to approve contract changes under \$100,000 without further City Council consideration.

Staff Report No. 54
  - B. Consideration of the approval of a bid tabulation and award of contract to McNamara Contracting, Inc. for the 2018 Concrete Sidewalk, Curb, and Gutter Repair project in the amount of \$811,507.25, and authorization of the City Manager to approve contract changes under \$100,000 without further City Council consideration.

Staff Report No. 55
  - C. Consideration of the approval of a resolution of support for the METRO Orange Line Bus Rapid Transit

Station and Knox Avenue Transitway Design.

Staff Report No. 56

- D. Consideration of the approval of issuance of a temporary on-sale intoxicating liquor license for the Blessed Trinity Catholic School, located at the Assumption Catholic Church, 305 East 77th Street, for their 2018 Fiesta event taking place April 28, 2018.

Staff Report No. 57

- E. Consideration of the approval of a resolution allowing acceptance of a grant for the Fire Department to purchase lifting safety equipment.

Staff Report No. 58

- F. Consideration of the approval of the purchase of a station alerting system from U.S. Digital Designs in the amount of \$114,500 for both Richfield fire stations.

Staff Report No. 59

- G. Consideration of the approval of a resolution appointing Bryan Kuffel to the Richfield Tourism Promotion Board to complete a three-year term ending December 31, 2018, or until a successor is chosen, whichever is later.

Staff Report No. 60

5. Consideration of items, if any, removed from Consent Calendar

### **PUBLIC HEARINGS**

6. Public hearing and consideration of the approval of a resolution for a preliminary plat of "Nora Corner" that will combine four parcels (6529 and 6545 Penn Avenue, and 2208 and 2210 66th Street West) into three parcels, in order to allow construction of a previously approved restaurant (Dunkin Donuts).

Staff Report No. 61

### **RESOLUTIONS**

7. Consideration of the approval of a resolution endorsing smoke-free multi-unit housing within the city of Richfield.

Staff Report No. 62

### **OTHER BUSINESS**

8. Consideration of the designation of a Mayor Pro Tempore for 2018.

Staff Report No. 63

### **CITY MANAGER'S REPORT**

9. City Manager's Report

### **CLAIMS AND PAYROLLS**

10. Claims and Payrolls

Open forum (15 minutes maximum)

***Each speaker is to keep their comment period to three minutes to allow sufficient time for others. Comments are to be an opportunity to address the Council on items not on the agenda. Individuals who wish to address the Council must have registered prior to the meeting.***

11. Adjournment

**Auxiliary aids for individuals with disabilities are available upon request. Requests must be made at least 96 hours in advance to the City Clerk at 612-861-9738.**



# CITY COUNCIL MEETING MINUTES

Richfield, Minnesota

## Regular Meeting

March 13, 2018

### CALL TO ORDER

The meeting was called to order by Mayor Elliott at 7:00 p.m. in the Council Chambers.

*Councilmembers Present:* Pat Elliott, Mayor; Edwina Garcia; Maria Regan Gonzalez; and Simon Trautmann.

*Absent:* Michael Howard.

*Staff Present:* Steven L. Devich, City Manager; Mary Tietjen, City Attorney; John Stark, Community Development Director; Jay Henthorne, Public Safety Director/Chief of Police; Wayne Kewitsch, Fire Chief; John Stark, Community Development Director; Jim Topitzhofer, Recreation Services Director; and Jared Voto, Executive Aide/Analyst.

### OPEN FORUM

Tony Redington, Upton Avenue, spoke regarding his attendance at a City Council meeting to earn extra credit for a college class.

### PLEDGE OF ALLEGIANCE

Mayor Elliott led the Pledge of Allegiance.

### APPROVAL OF MINUTES

M/Trautmann, S/Garcia to approval of the minutes of the: (1) Special City Council work session of February 27, 2018; and (2) Regular City Council meeting of February 27, 2018.

Motion carried 4-0.

<b>Item #2</b>	<b>COUNCIL DISCUSSION</b> <ul style="list-style-type: none"> <li>Hats Off to Hometown Hits</li> <li>Attending the Richfield Red, White, &amp; Blue Days Parade (4th of July)</li> </ul>
----------------	---

Mayor and Councilmembers discussed plans to attend the Richfield Red, White, & Blue Days Parade.

Mayor Elliott spoke regarding the 66th Street Reconstruction Season Kick-off Open House on March 14; the Comprehensive Plan Open House on March 15; invited members of the public to sign up to become election judges; nominating City Manager Devich for MCMA City Manager of the Year; VEAP's 19th Annual Gala on April 27; an invitation from Hennepin County for funding for curb side organics collection; annual City Council and staff goals setting on March 22; and the State of the City speech on March 23.

Councilmember Regan Gonzalez spoke regarding a joint Advisory Board of Health meeting with Bloomington and Edina; the 2017 City of Richfield Annual Report; the organics taskforce meeting on March 7; and thanked the Richfield Police Department for attending the community conversation at Church of the Assumption.

Councilmember Garcia spoke regarding the 2017 City of Richfield Annual Report and thanked staff and Council for their work putting it together and invited residents to attend the Richfield Historical Society's event on March 21 at the Community Center regarding how the state's got their shapes.

Councilmember Trautmann spoke regarding the Friends of Wood Lake (FOWL) fundraising event on April 27; a Wood Lake Nature Center event titled "All about Woodpeckers"; and March 17 is the final day to register children for Richfield baseball.

Councilmember Garcia also mentioned Police Department Open House on March 20 to solicit comments on police body cameras and the indoor farmers market on April 5.

<b>Item #3</b>	<b>APPROVAL OF THE AGENDA</b>
----------------	-------------------------------

M/Regan Gonzalez, S/Trautmann to approve the agenda.

Motion carried 4-0.

<b>Item #4</b>	<b>CONSENT CALENDAR</b>
----------------	-------------------------

City Manager Devich presented the consent calendar.

- A. Consideration of the approval of the purchase of a Fire Pumper Chassis for \$199,884 in 2018 and a Fire Pumper Body for \$292,860 in 2019, totaling \$492,744, from Rosenbauer Firefighting Technology. (S.R. No. 47)
- B. Consideration of the approval of a resolution supporting projects impacting the City of Richfield that were submitted to the Minnesota Department of Transportation's Corridors of Commerce program. (S.R. No. 48)

RESOLUTION NO. 11481  
 RESOLUTION APPROVING SUBMITTED PROJECTS TO THE STATE  
 OF MINNESOTA'S 2018 CORRIDORS OF COMMERCE PROGRAM  
 THAT IMPACT THE CITY OF RICHFIELD

This resolution appears as Resolution No. 11481.

- C. Consideration of the adoption of the City of Richfield Sustainable Purchasing Policy. (S.R. No. 49)
- D. Consideration of the approval of a contract with Becker Arena Products, Inc. to replace the dasher boards in Rink One in the amount of \$159,145.44 and to authorize the City Manager both to execute the contract and to approve additional work up to \$10,000 without further City Council authorization. (S.R. No. 50)

M/Elliott, S/Garcia to approve the consent calendar.

Motion carried 4-0.

<b>Item #4</b>	<b>CONSIDERATION OF ITEMS, IF ANY, REMOVED FROM THE CONSENT CALENDAR</b>
----------------	--

None.

<b>Item #5</b>	<b>PUBLIC HEARING AND CONSIDERATION OF THE APPROVAL OF NEW ON-SALE INTOXICATING AND SUNDAY LIQUOR LICENSES FOR LYNDAL SMOKEHOUSE, LLC D/B/A LYNDAL SMOKEHOUSE LOCATED AT 7745 LYNDAL AVE SOUTH. (S.R. NO. 51)</b>
----------------	---

Councilmember Garcia presented Staff Report No. 51.

M/Elliott, S/Garcia to close the public hearing

Motion carried 4-0.

M/Garcia, S/Elliott to approve the issuance of new On-Sale Intoxicating and Sunday Liquor licenses for Lyndale Smokehouse, LLC d/b/a Lyndale Smokehouse located at 7745 Lyndale Ave South.

Motion carried 4-0.

<b>Item #6</b>	<b>PUBLIC HEARING AND CONSIDERATION OF THE APPROVAL OF AN ORDINANCE AMENDMENT TO THE RICHFIELD CITY CODE APPENDIX D EXHIBIT A (CONSTRUCTION AND RELATED PERMIT FEES AND CHARGES) TO PROVIDE BUILDING PERMIT FEE REDUCTIONS TO AFFORDABLE HOUSING DEVELOPMENTS AND APPROVE A RESOLUTION AUTHORIZING SUMMARY PUBLICATION OF THE ORDINANCE AMENDMENT. (S.R. NO. 52)</b>
----------------	--

Councilmember Trautmann presented Staff Report No. 52.

Councilmember Trautmann asked if the affordable housing options that were for both rental and homeownership opportunities.

Community Development Director Stark responded that was correct.

M/Elliott, S/Garcia to close the public hearing

Motion carried 4-0.

M/Trautmann, S/Regan Gonzalez to approve an ordinance amendment to Richfield City Code Appendix D Exhibit A (Construction and Related Permit Fees and Charges) and approve a resolution authorizing summary publication of the ordinance amendment.

RESOLUTION NO. 11482  
RESOLUTION APPROVING SUMMARY PUBLICATION OF AN  
ORDINANCE AMENDING APPENDIX D TO THE RICHFIELD CITY  
CODE; ESTABLISHING A FEE SCHEDULE FOR CERTAIN PERMITS  
AND APPLICATIONS

Motion carried 4-0. This resolution appears as Resolution No. 11482.

Councilmembers made statements thanking staff for their work on affordable housing in Richfield.

<b>Item #7</b>	<b>CONSIDERATION OF THE ADOPTION OF THE RESOLUTION WITH FINDINGS REVOKING THE BUSINESS LICENSE FOR FIRST STEP, LLC (D/B/A RICHFIELD HEALTH MASSAGE). (S.R. NO. 53)</b>
----------------	--

Mayor Elliott presented Staff Report No. 53.

Councilmember Regan Gonzalez asked about supporting individuals involved in this with a T visa.

Chief Henthorne responded if individuals made an application they would review, sign off, and send it to the proper authorities.

M/Elliott, S/Trautmann to approve the adoption of the Resolution with Findings, revoking the business license for First Step, LLC.

RESOLUTION NO. 11483  
RESOLUTION AUTHORIZING THE REVOCATION OF THE  
THERAPEUTIC MASSAGE ENTERPRISE LICENSE OF FIRST STEP,  
LLC (D/B/A RICHFIELD HEALTH MASSAGE) LOCATED AT 7610  
LYNDALE AVENUE SOUTH, SUITE 400, RICHFIELD, MN 55423

Motion carried 4-0. This resolution appears as Resolution No. 11483.

<b>Item #8</b>	<b>CITY MANAGER’S REPORT</b>
----------------	------------------------------

City Manager Devich stated he had nothing to report.

<b>Item #9</b>	<b>CLAIMS AND PAYROLLS</b>
----------------	----------------------------



M/Garcia, S/Elliott that the following claims and payrolls be approved:

<b>U.S. Bank</b>	<b>03/13/18</b>
A/P Checks: 266299 - 266636	\$ 1,287,621.66
Payroll: 134827 - 135166	<u>717,154.68</u>
TOTAL	\$ 2,004,776.34

Motion carried 4-0.

**OPEN FORUM**

None.

<b>Item #10</b>	<b>ADJOURNMENT</b>
-----------------	--------------------

The meeting was adjourned by unanimous consent at 7:35 p.m.

Date Approved: March 27, 2018

---

Pat Elliott  
Mayor

---

Jared Voto  
Executive Aide/Analyst

---

Steven L. Devich  
City Manager



**STAFF REPORT NO. 54**  
**CITY COUNCIL MEETING**  
**3/27/2018**

REPORT PREPARED BY: Logan Vlasaty, Civil Engineer

DEPARTMENT DIRECTOR REVIEW: Kristin Asher, Public Works Director  
3/19/2018

OTHER DEPARTMENT REVIEW: N/A

CITY MANAGER REVIEW: Steven L. Devich, City Manager  
3/21/2018

**ITEM FOR COUNCIL CONSIDERATION:**

**Consideration of the approval of a bid tabulation and award of contract to Bituminous Roadways Inc. for the 2018 Mill and Overlay project in the amount \$1,573,102, and authorization of the City Manager to approve contract changes under \$100,000 without further City Council consideration.**

**EXECUTIVE SUMMARY:**

This is the fourth year of the six year Accelerated Mill and Overlay Program. Approximately 14 miles of residential roads will receive mill and overlay in 2018. The residential roads have not received any major resurfacing since they were originally constructed in the 1970s. To prepare for this year's mill and overlay, repairs to curbs, sidewalks, catch basins, and manholes were completed in 2017. CenterPoint Energy also completed installation of new gas lines and services prior to the mill and overlay project.

For roads that are adequate candidates, mill and overlay is a cost effective maintenance solution that provides most of the benefits of new construction at a fraction of the cost. The surface is milled to remove the top 2"-3" of asphalt and a new asphalt top layer is applied improving the surface integrity of the road and eliminating patching needs. Typically the base layer of these roads is found to be in good condition. In conjunction with regular maintenance, the life of a roadway can be extended beyond the original intended life of 20-30 years.

Bids for the mill and overlay project were opened on March 8, 2018. Bituminous Roadways Inc. was the lowest responsive and responsible bidder in the amount of \$1,573,102.

**RECOMMENDED ACTION:**

**By motion: Approve the bid tabulation and award of contract to Bituminous Roadways Inc. in the amount of \$1,573,102 for the 2018 Mill and Overlay project and authorize the City Manager to approve contract changes under \$100,000 without further City Council authorization.**

**BASIS OF RECOMMENDATION:**

**A. HISTORICAL CONTEXT**

- The residential roads were originally constructed between 1972 and 1977. A pavement management program began in 1980. That policy direction was set to protect the City's capital investment and maintain an acceptable roadway system. The City's ongoing preventive

maintenance program is essential in delaying the costs associated with total reconstruction.

- In September 2014, residential mill and overlay was approved in the Five-Year Reconstruction Plan for the purpose of utilizing Street Reconstruction Bonds to finance the work in place of special assessments. The bonds are paid down by an increase in the electric and gas franchise fees, effective April 2014.
- Approximately 85 miles of roadway will be milled and overlaid as part of the six year program.

**B. POLICIES (resolutions, ordinances, regulations, statutes, etc):**

- The City has adopted a pavement management program to maintain the quality of the road and prolong the life of the capital investment (Comprehensive Plan – Road Pavement Conditions).
- In 2013, the City Council approved an Accelerated Mill and Overlay Program to complete the remaining 85 miles of roads that have not received any major resurfacing since they were constructed. This program also includes the repair of storm and sanitary manholes and catch basins.
- An increase in electric and gas franchise fees was approved in 2013, and enacted in April 2014, to fund the Accelerated Mill and Overlay Program.

**C. CRITICAL TIMING ISSUES:**

- The mill and overlay work is scheduled to begin May 7, 2018, and be completed by June 29, 2018.
- Regular preventive maintenance techniques are effective in delaying costly street reconstruction projects.

**D. FINANCIAL IMPACT:**

- Eight (8) bids were received for the 2018 Mill and Overlay project.
- The lowest responsive and responsible bid was \$1,573,102 submitted by Bituminous Roadways, Inc.
- This work is funded by franchise fees.
- A recent history of bid prices for mill and overlay:

<u>Year</u>	<u>Bid Price Asphalt (ton)</u>	<u>Contractor</u>
2008	\$40.00	Harddrives
2010	\$47.00	Valley Paving
2015	\$52.00	Harddrives
2016	\$40.80	Park Construction
2017	\$37.00	Bituminous Roadways
2018	\$36.85	Bituminous Roadways

- Additional work may be added or subtracted from the mill and overlay contract depending on actual cost of construction.

**E. LEGAL CONSIDERATION:**

- When the amount of purchase is estimated to exceed \$100,000, sealed bids shall be solicited by public notice in the manner and subject to the law governing contracts or purchases by the City of Richfield.
- The advertisement for bid for the project was published in the Richfield Sun-Current on February 22, 2018, and on the Questcdn.com website on February 22, 2018.
- Bid opening was held on March 8, 2018. A copy of the bid tabulation is attached.

**ALTERNATIVE RECOMMENDATION(S):**

- None

**PRINCIPAL PARTIES EXPECTED AT MEETING:**

None

**ATTACHMENTS:**

Description	Type
☐ Bid Tabulation	Backup Material

▣ Mill and Overlay Map

Backup Material

**CITY OF RICHFIELD, MINNESOTA**

Bid Opening  
March 8, 2018  
9:00 a.m.

2018 Mill and Overlay Project  
Bid No. 18-02

Pursuant to requirements of Resolution No. 1015, a meeting of the Administrative Staff was called by Elizabeth VanHoose, City Clerk, who announced that the purpose of the meeting was to receive; open and read aloud bids for the 2018 Mill and Overlay Project, as advertised in the official newspaper on February 22, 2018.

Present: Elizabeth VanHoose, City Clerk  
Liz Finnegan, Civil Engineer  
Logan Vlasaty, Civil Engineer  
Jared Voto, City Manager Representative

The following bids were submitted and read aloud:

Bidder's Name	Bond	Non-Collusion	Intent to Comply	Responsible Contractor	Total Base Bid
Hardrives, Inc.	Yes	Yes	Yes	Yes	\$1,941,315.60
North Valley, Inc.	Yes	Yes	Yes	Yes	\$1,782,463.93
Dark Construction, LLC	Yes	Yes	Yes	Yes	\$1,748,847.60
CS McCrossan, Inc.	Yes	Yes	Yes	Yes	\$2,042,320.00
Northwest Asphalt	Yes	Yes	Yes	Yes	\$1,846,658.00
McNamara Contracting, Inc.	Yes	Yes	Yes	Yes	\$2,000,000.00
Valley Paving, Inc.	Yes	Yes	Yes	Yes	\$1,766,140.00
Bituminous Roadways, Inc.	Yes	Yes	Yes	Yes	\$1,573,102.00

The City Clerk announced that the bids would be tabulated and considered at the March 27, 2018 City Council Meeting.

Elizabeth VanHoose

City Clerk

# Proposed Mill & Overlay Areas

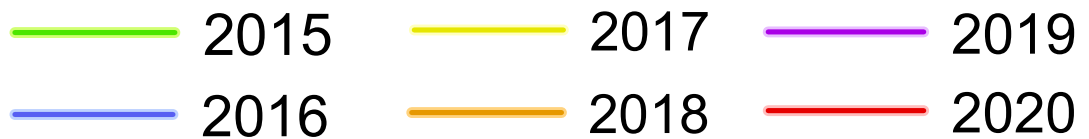
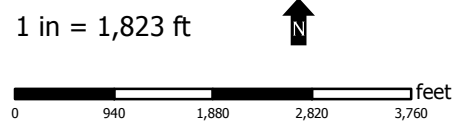
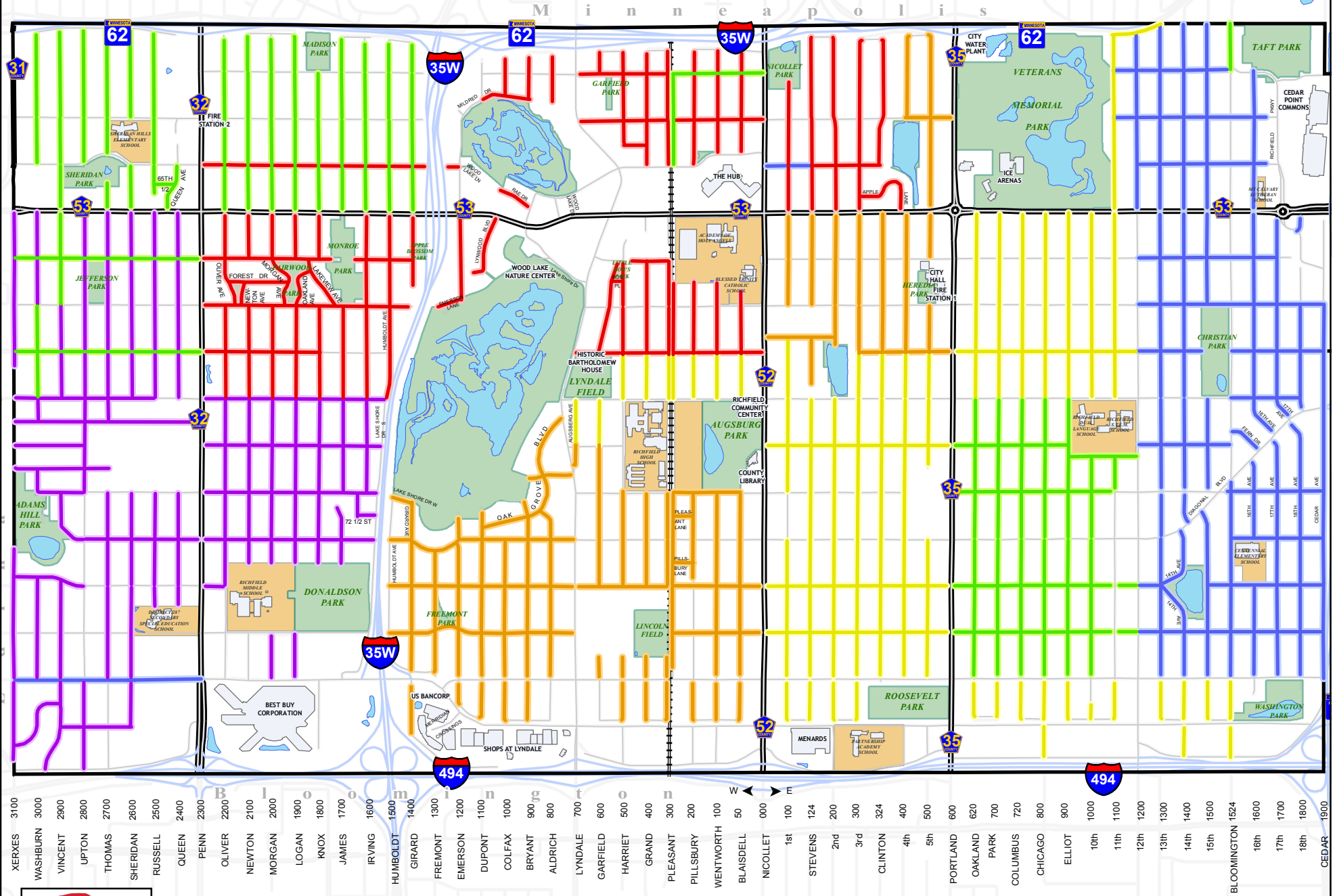

Date: 2/22/2018



**STAFF REPORT NO. 55**  
**CITY COUNCIL MEETING**  
**3/27/2018**

REPORT PREPARED BY: Logan Vlasaty, Civil Engineer

DEPARTMENT DIRECTOR REVIEW: Kristin Asher, Public Works Director  
3/19/2018

OTHER DEPARTMENT REVIEW: N/A

CITY MANAGER REVIEW: Steven L. Devich, City Manager  
3/21/2018

**ITEM FOR COUNCIL CONSIDERATION:**

**Consideration of the approval of a bid tabulation and award of contract to McNamara Contracting, Inc. for the 2018 Concrete Sidewalk, Curb, and Gutter Repair project in the amount of \$811,507.25, and authorization of the City Manager to approve contract changes under \$100,000 without further City Council consideration.**

**EXECUTIVE SUMMARY:**

With the implementation of the city-wide Accelerated Mill and Overlay Program, concrete repairs are concentrated in the mill and overlay areas. This will ensure the concrete repairs are completed the year before the area is scheduled for mill and overlay. The project includes replacement of cracked and heaved sidewalk, curb, gutter, and other concrete, as necessary. All catch basins and manhole structures in the area are also inspected and, if necessary, repaired as part of this project. A map of the locations for the 2018 work is attached.

Bids for the concrete repair project were opened on March 8, 2018. McNamara Contracting, Inc. was the lowest responsive and responsible bidder in the amount of \$811,507.25.

**RECOMMENDED ACTION:**

**By motion: Approve the bid tabulation and award of contract to McNamara Contracting, Inc. in the amount of \$811,507.25 for 2018 Concrete Sidewalk, Curb, and Gutter Repair project and authorize the City Manager to approve contract changes under \$100,000 without further City Council authorization.**

**BASIS OF RECOMMENDATION:**

**A. HISTORICAL CONTEXT**

- As part of the City's street maintenance program, cracked and heaved sidewalk, curb and gutter, and other concrete work is completed each year.
- The program was expanded in 2015 in preparation for the Accelerated Mill and Overlay Program. Concrete repairs are concentrated in the area of the next year's mill and overlay.
- The project includes rebuilding catch basins and manhole structures in preparation for mill and overlay.

**B. POLICIES (resolutions, ordinances, regulations, statutes, etc):**

- The project is included in the Five-Year Street Reconstruction Plan.
- In 2013, the City approved an Accelerated Mill and Overlay Program to complete the remaining 85 miles of roads that have not received any major resurfacing since they were constructed. This program also includes concrete repair of storm and sanitary manholes and catch basins.
- An increase in electric and gas franchise fees was approved in 2013, and enacted in April 2014, to fund the Accelerated Mill and Overlay Program.
- Per the City's American with Disabilities Act (ADA) Transition Plan, sidewalks, trails, and crossings are brought into compliance with the current ADA requirements.

**C. CRITICAL TIMING ISSUES:**

- Concrete repair work is scheduled to begin July 9, 2018, and be completed by October 5, 2018.
- Concrete repairs should be completed the year prior to mill and overlay to avoid delays to the 2019 Mill and Overlay schedule.

**D. FINANCIAL IMPACT:**

- Five (5) bids were received for the concrete repairs.
- The lowest responsive and responsible bid was \$811,507.25 submitted by McNamara Contracting, Inc.
- The work is funded by franchise fees.

**E. LEGAL CONSIDERATION:**

- When the amount of purchase is estimated to exceed \$100,000, sealed bids shall be solicited by public notice in the manner and subject to the law governing contracts or purchases by the City of Richfield.
- The advertisement for bid for the project was published in the Richfield Sun-Current on February 22, 2018, and on the Questcdn.com website on February 22, 2018.
- Bid opening was held on March 8, 2018. A copy of the bid tabulation is attached.

**ALTERNATIVE RECOMMENDATION(S):**

- None

**PRINCIPAL PARTIES EXPECTED AT MEETING:**

None

**ATTACHMENTS:**

	Description	Type
□	Bid Tabulation	Backup Material
□	Concrete Map	Backup Material



**CITY OF RICHFIELD, MINNESOTA**

Bid Opening  
March 8, 2018  
9:30 a.m.

2018 Concrete Sidewalk, Curb, and Gutter Repair Project  
Bid No. 18-03

Pursuant to requirements of Resolution No. 1015, a meeting of the Administrative Staff was called by Elizabeth VanHoose, City Clerk, who announced that the purpose of the meeting was to receive; open and read aloud bids for the 2018 Concrete Sidewalk, Curb, and Gutter Repair Project, as advertised in the official newspaper on February 22, 2018.

Present: Elizabeth VanHoose, City Clerk  
Liz Finnegan, Civil Engineer  
Logan Vlasaty, Civil Engineer  
Jared Voto, City Manager Representative

The following bids were submitted and read aloud:

Bidder's Name	Bond	Non-Collusion	Intent to Comply	Responsible Contractor	Total Base Bid
Standard Sidewalk, Inc.	Yes	Yes	Yes	Yes	\$961,925.00
McNamara Contracting, Inc.	Yes	Yes	Yes	Yes	\$811,507.25
Ti-Zack Concrete, Inc.	Yes	Yes	Yes	Yes	\$990,668.00
Ryan Contracting	Yes	Yes	Yes	Yes	\$812,900.00
New Look Contracting, Inc.	Yes	Yes	Yes	Yes	\$920,825.00

The City Clerk announced that the bids would be tabulated and considered at the March 27, 2018 City Council Meeting.

\_\_\_\_\_  
Elizabeth VanHoose                      City Clerk

# Concrete 2018

I:\GIS\Public Works Engineering\StreetMgmt\Projects\Concrete 2018.mxd

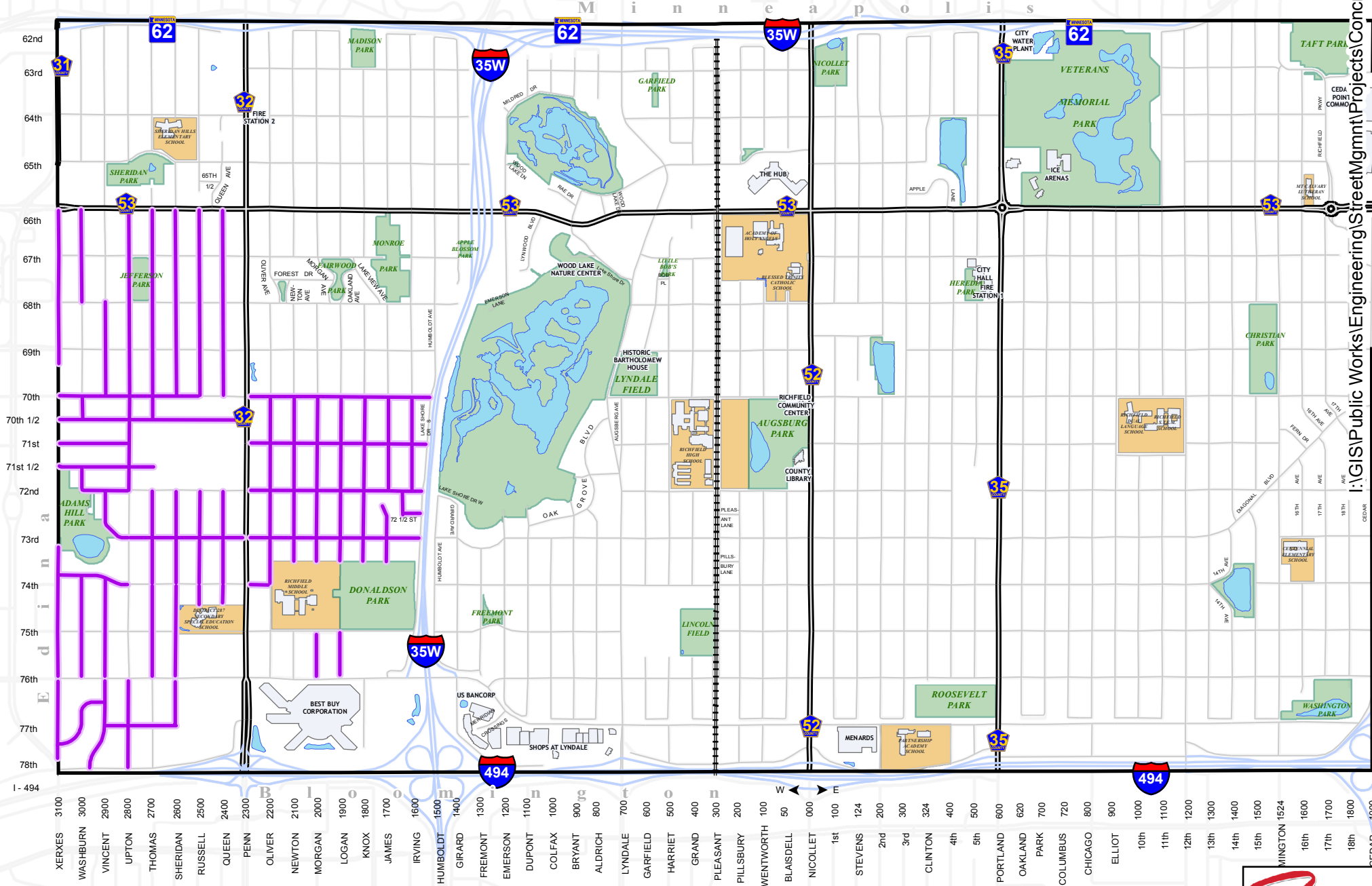

Date: 2/22/2018

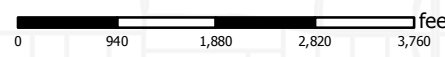

1 in = 1,823 ft





**STAFF REPORT NO. 56**  
**CITY COUNCIL MEETING**  
**3/27/2018**

REPORT PREPARED BY: Jeff Pearson, City Engineer

DEPARTMENT DIRECTOR REVIEW: Kristin Asher, Public Works Director  
3/20/2018

OTHER DEPARTMENT REVIEW: N/A

CITY MANAGER REVIEW: Steven L. Devich, City Manager  
3/21/2018

**ITEM FOR COUNCIL CONSIDERATION:**

**Consideration of the approval of a resolution of support for the METRO Orange Line Bus Rapid Transit Station and Knox Avenue Transitway Design.**

**EXECUTIVE SUMMARY:**

**Background**

The METRO Orange Line is a planned Bus Rapid Transit (BRT) line between downtown Minneapolis and Burnsville. The Orange Line will use roadway improvements, upgraded transit stations, Park & Ride facilities, and improved bus routes to provide fast, frequent, and reliable all-day service along I-35W. The goal is to operate with the service, quality, and reliability of rail transit while benefitting from the cost savings and flexibility of bus transit.

Richfield will have Orange Line stations at 66th Street & I-35W and at 76th Street & Knox Avenue. Final plans have been completed for these stations. Additionally, the final layout for the Knox Avenue Transitway underneath I-494 is set with plans nearing completion. Both the station plans and Transitway layout was presented to the City Council at the February 27, 2018, work session.

Metro Transit does not require municipal consent for their projects. However, since the plans must be signed by the City Engineer, staff feels it would be appropriate to have a resolution of City Council support of these plans.

**Additional Project Details and Improvements**

- METRO Orange Line buses will use transit advantages on Marquette and 2nd Avenues in downtown Minneapolis, providing faster service and increased capacity. South of downtown, the Orange Line will provide frequent, limited-stop service via I-35W to upgraded stations at Lake Street, 46th Street, 66th Street, 76th Street/Knox Avenue, American Boulevard/Knox Avenue, 98th Street, Burnsville Heart of the City and Burnsville Parkway.
- In the future, a second phase of the project could extend service from Burnsville to Lakeville.
- The Orange Line will provide direct connections to planned transit improvements at Lake Street and American Boulevard, and provide convenient connections to the METRO Blue and Green lines in downtown Minneapolis.
- The line will also connect with local bus service and several Park & Ride lots.
- All Orange Line stations will have upgrades in platform ticketing, information technology, and customer

amenities, similar to light rail transit.

**RECOMMENDED ACTION:**

**By motion: Approve a resolution of support for the METRO Orange Line Bus Rapid Transit Station and Knox Avenue Transitway Design.**

**BASIS OF RECOMMENDATION:**

**A. HISTORICAL CONTEXT**

- See Executive Summary

**B. POLICIES (resolutions, ordinances, regulations, statutes, etc):**

- The METRO Orange Line BRT is consistent with the City's Comprehensive Plan (Transportation p. 6-39).
- The station plans and Transitway layout were presented to the City Council at the February 27, 2018, work session.
- The Knox Avenue alignment is consistent with the initial City Council resolution of support for the transit line from May 27, 2014.

**C. CRITICAL TIMING ISSUES:**

- Metro Transit has applied for federal funding and will begin construction as early as 2019 if funding is successful.

**D. FINANCIAL IMPACT:**

- There are no financial impacts to the resolution of support.
- Project cost is split between federal, state and county funding.
- The City is not providing any funding to the project other than limited cost of staff time for coordination during construction.

**E. LEGAL CONSIDERATION:**

- The City Attorney will be available to answer questions.

**ALTERNATIVE RECOMMENDATION(S):**

- None

**PRINCIPAL PARTIES EXPECTED AT MEETING:**

None

**ATTACHMENTS:**

Description	Type
☐ Station and Layout Presentation	Backup Material
☐ Resolution	Resolution Letter
☐ Orange Line Handout	Backup Material

# Orange Line Station Plan



**February 27, 2018**



# Station Furnishings

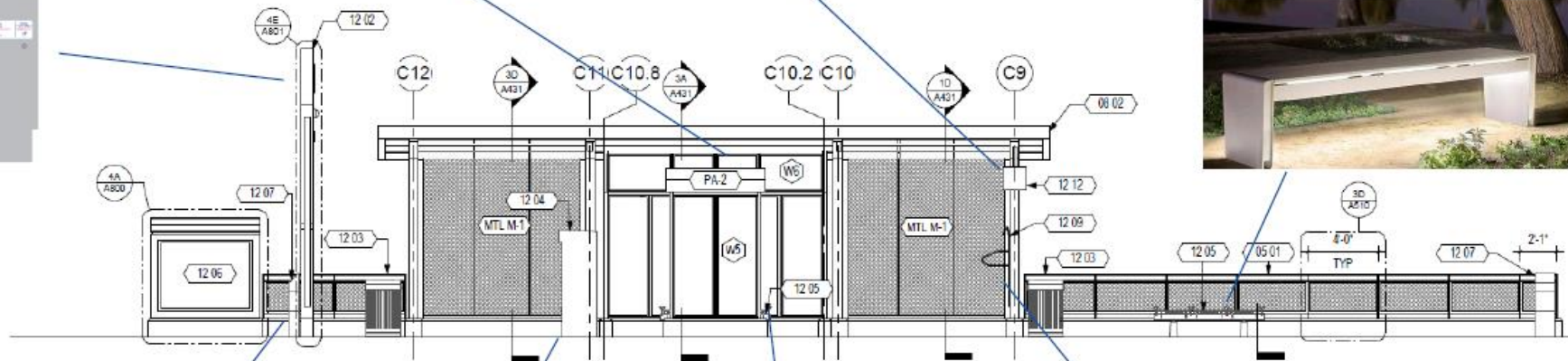
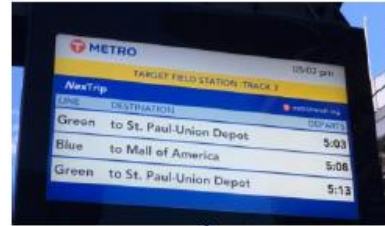

98TH STREET STATION SOUTHBOUND-FRONT ELEVATION



# 66<sup>th</sup> Street Station



# 66<sup>th</sup> Street Station

## Station Layout











-  Connecting eastbound bus stops
-  Connecting westbound bus stops
-  walking route
-  walking route



# 66<sup>th</sup> Street Station

## Northbound Station

-  MARKER
-  INFORMATION KIOSK
-  TICKET VENDING MACHINE (BY OTHERS)
-  TICKET VALIDATOR (BY OTHERS)
-  TRASH RECEPTACLE
-  BENCH
-  VERTICAL BIKE RACK
-  2' WIDE TACTILE WARNING PLATES

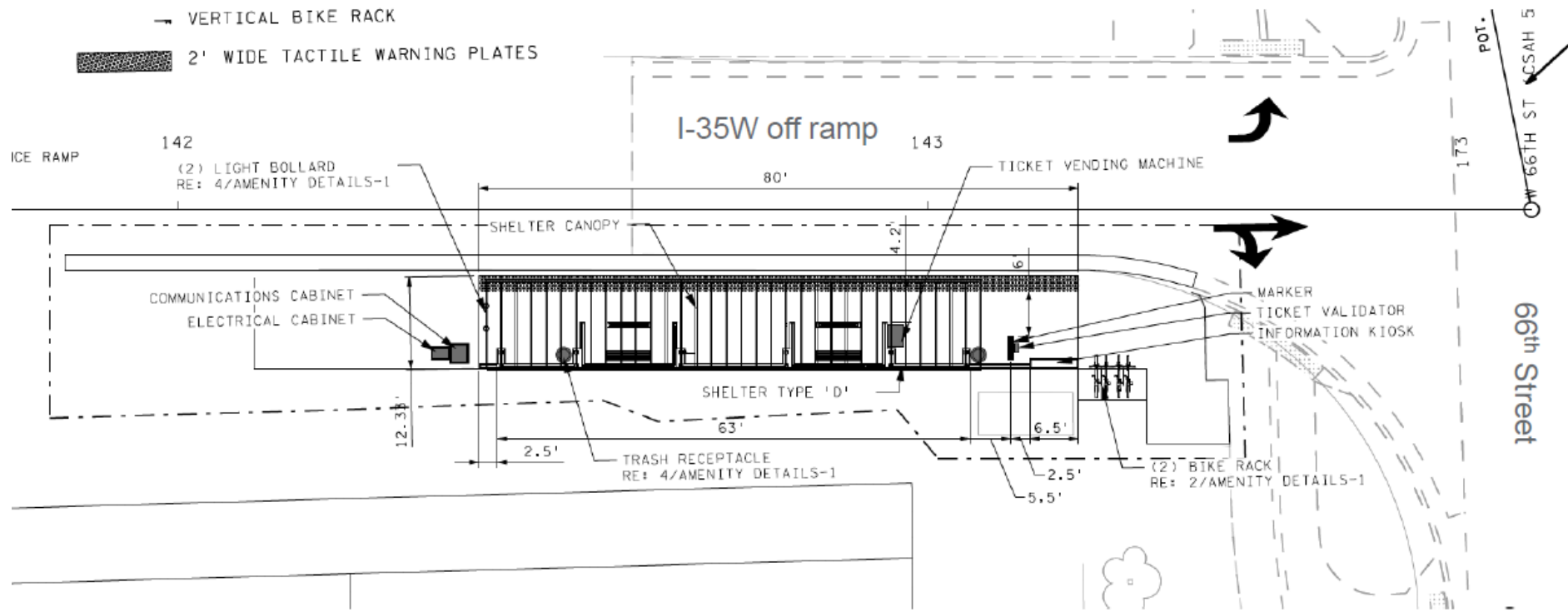

# 66<sup>th</sup> Street Station

## Northbound Station

North to I-35W

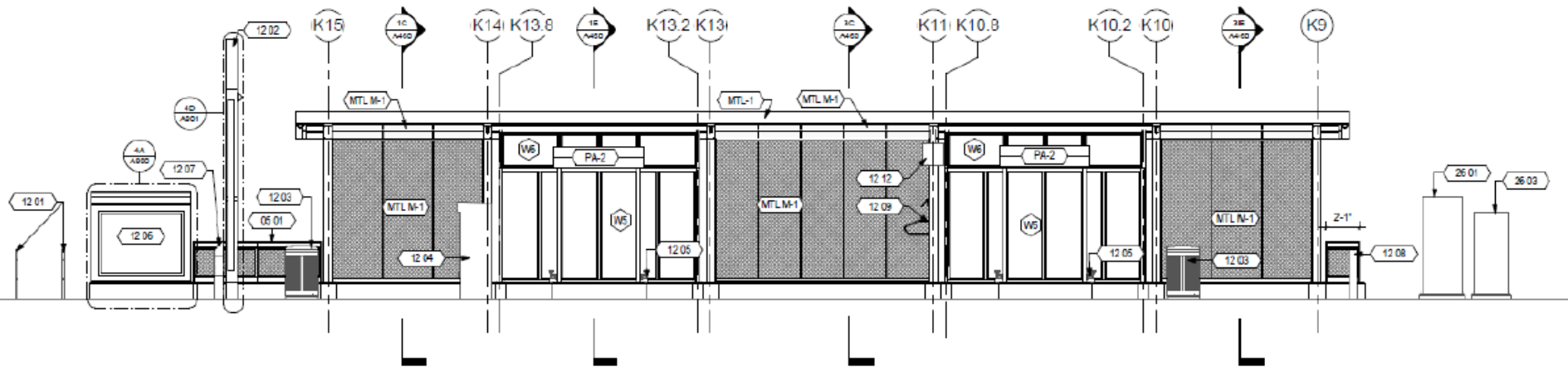

66TH STREET NORTHBOUND - ELEVATION

I-35W off ramp

# 66<sup>th</sup> Street Station

## Southbound Station

- MARKER
- INFORMATION KIOSK
- TICKET VENDING MACHINE (BY OTHERS)
- ▣ TICKET VALIDATOR (BY OTHERS)
- TRASH RECEPTACLE
- ▬ BENCH
- ↕ VERTICAL BIKE RACK
- ▨ 2' WIDE TACTILE WARNING PLATES

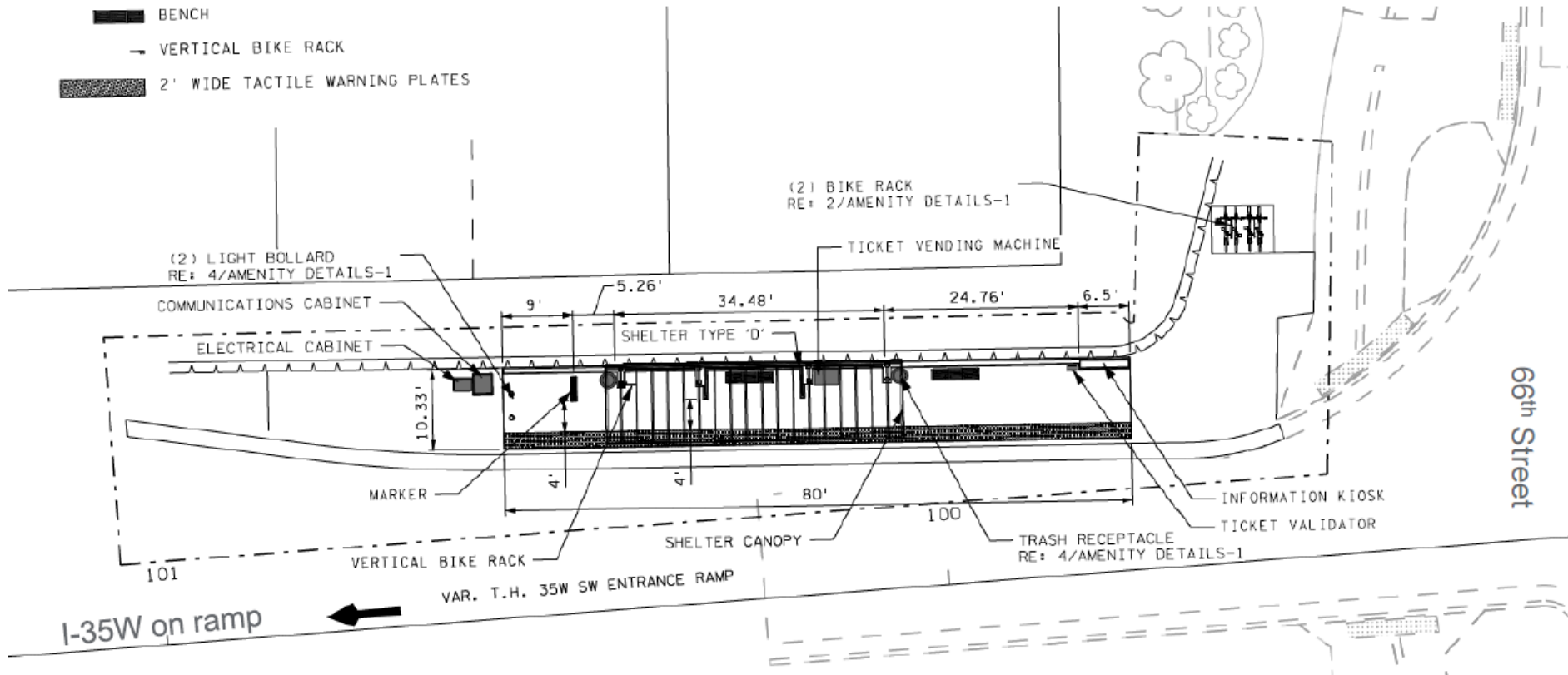

# 66<sup>th</sup> Street Station

## Southbound Station

South to I-35W

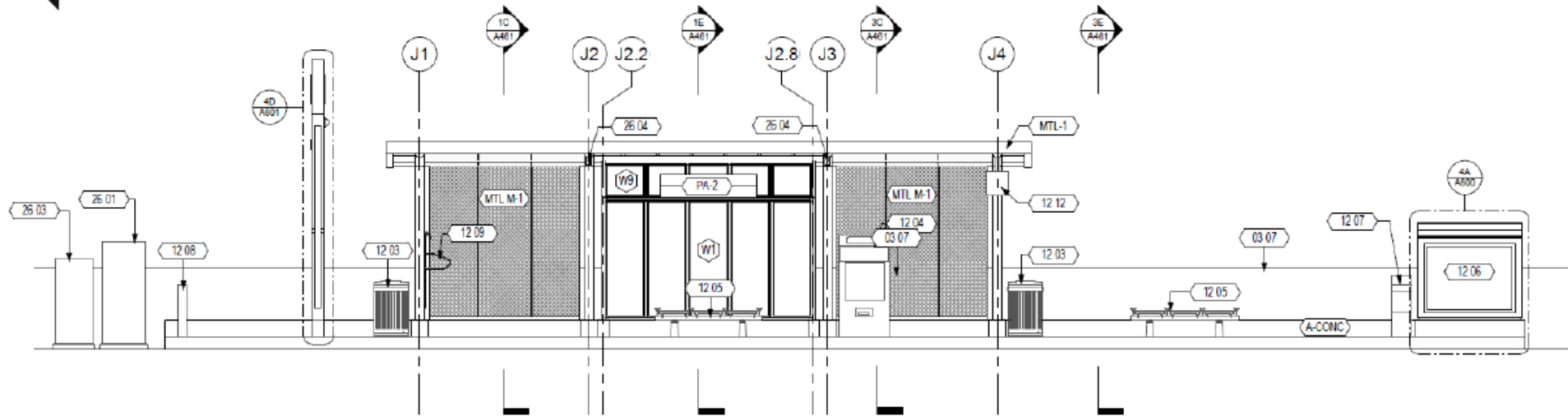

1C 66TH STREET SOUTHBOUND - ELEVATION

I-35W on ramp

# International Blvd Station (76<sup>th</sup> St)



# International Blvd Station (76<sup>th</sup> St)

## Station Layout

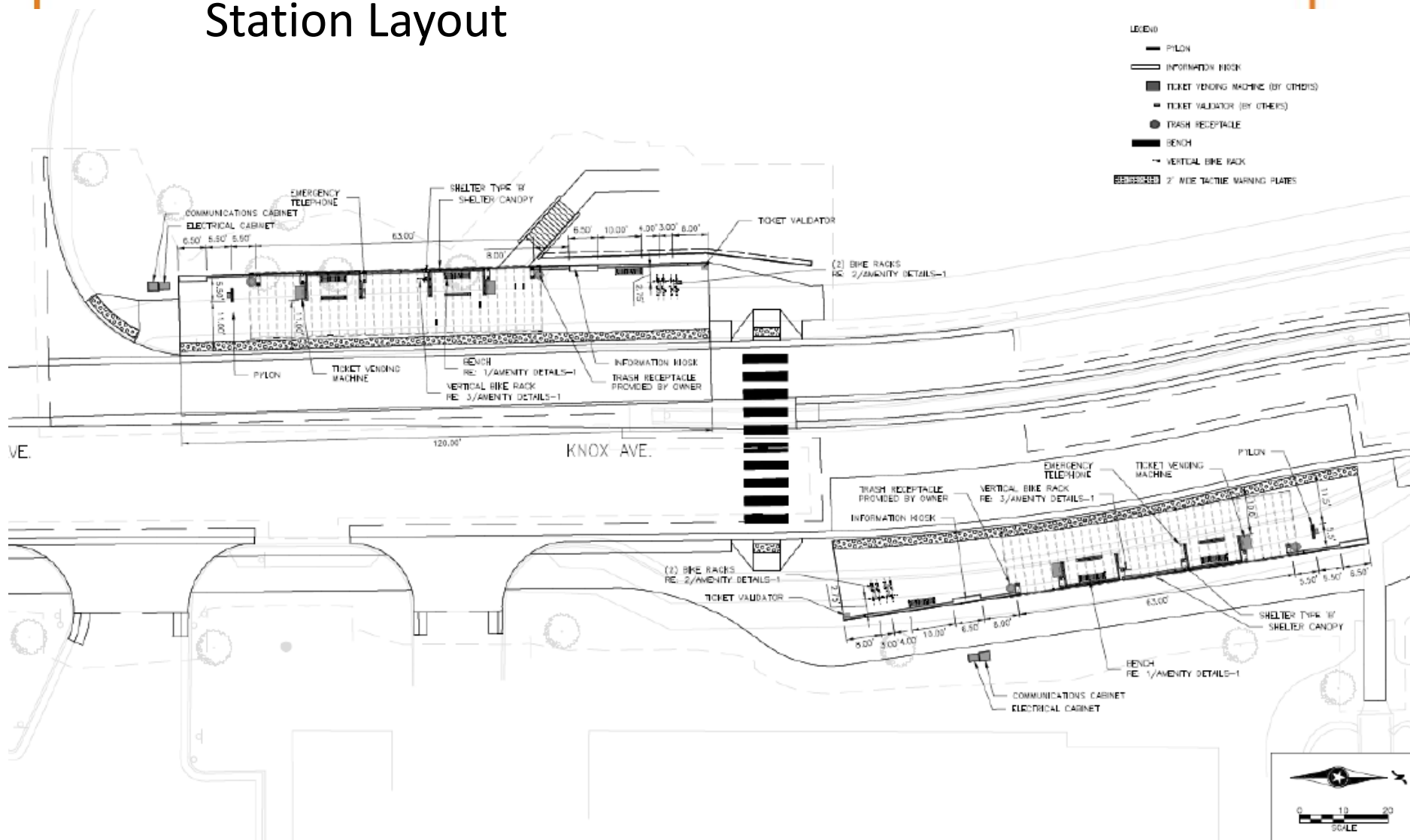

DESIGNED BY:	CHIEF OF:

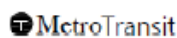

WE HEREBY CERTIFY THAT THIS FINAL SPECIFICATION OR REPORT WAS PREPARED BY ME OR UNDER MY DIRECT SUPERVISION AND THAT I AM A FULLY LICENSED PROFESSIONAL ENGINEER UNDER THE LAWS OF THE STATE OF ILLINOIS.

CERTIFIED BY

76TH STREET AND AMERICAN BOULEVARD STATIONS  
URBAN DESIGN PLAN - 76TH STREET

# International Blvd Station (76<sup>th</sup> St)

## Southbound Station

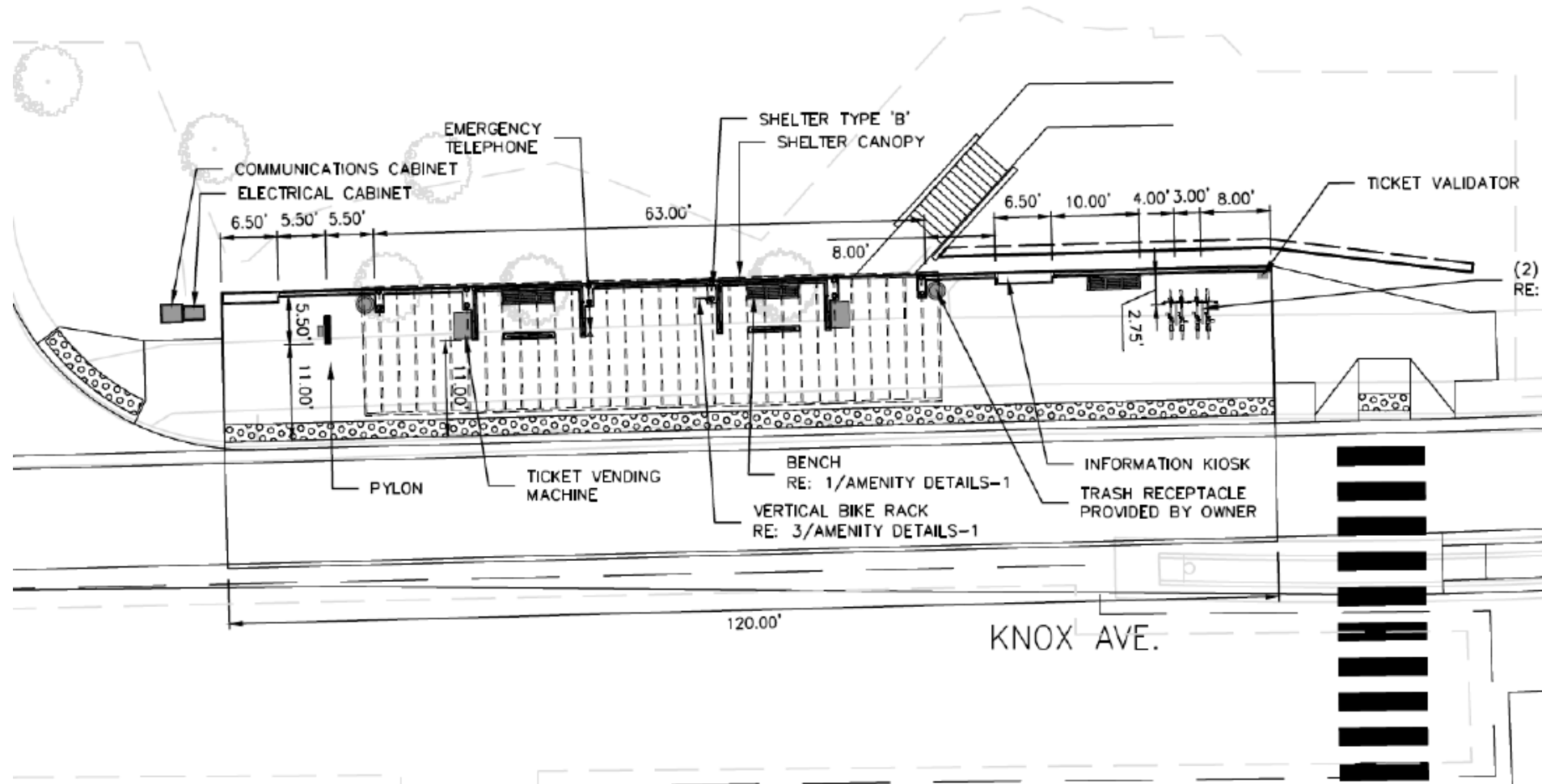







# International Blvd Station (76<sup>th</sup> St)

## Northbound Station

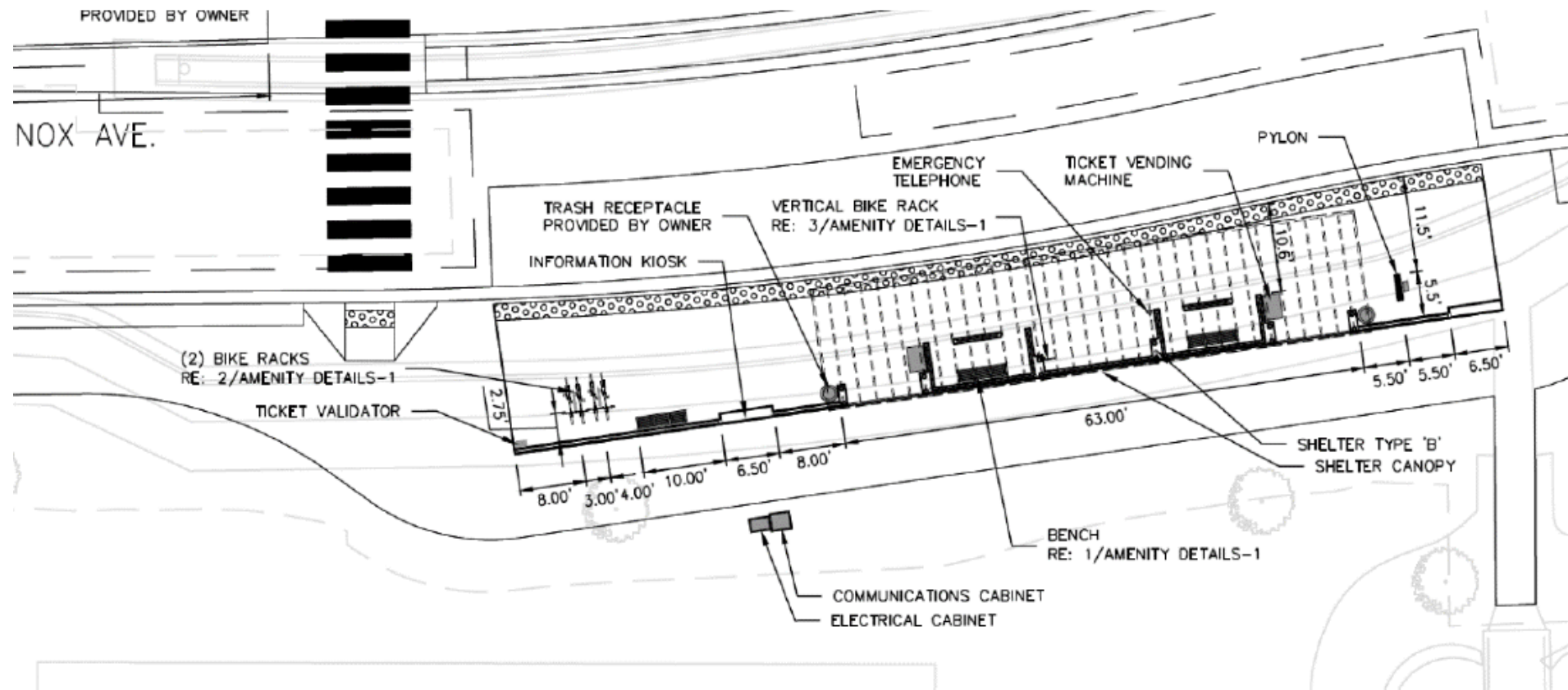

# International Blvd Station (76<sup>th</sup> St)

## Northbound Station

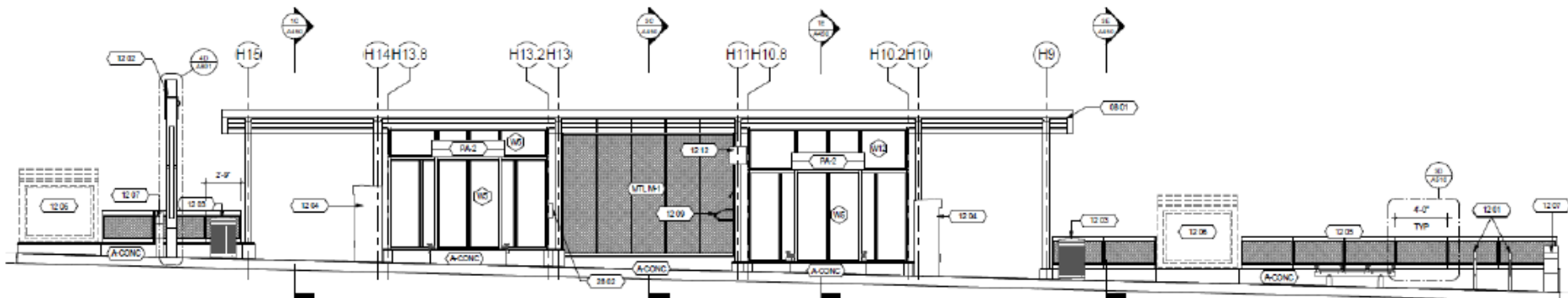

76TH STREET NORTHBOUND - ELEVATION

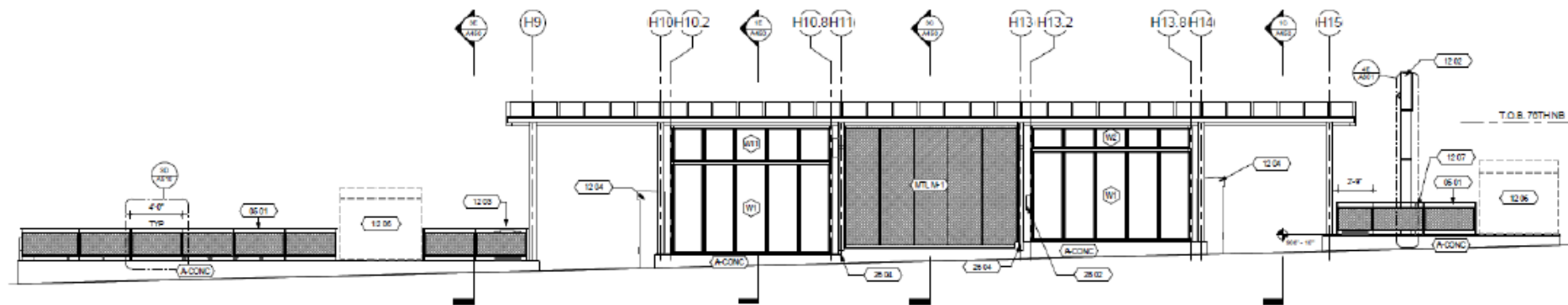

76TH STREET NORTHBOUND - ELEVATION



### GENERAL NOTES

- 1.
- 2.
- 4.

### KEYNOTES

- 65-01 CURB/FALL WITH METAL MESH
- 68-01 POLYCARBONATE CANOPY
- MOUNTED LOOPED DIAZ RACK, SEE URBAN DESIGN DWGS
- 12-01 WASTE RECEPTACLE, SEE URBAN DESIGN DWGS
- 12-02 MARKER
- 12-03 WASTE RECEPTACLE, SEE URBAN DESIGN DWGS
- 12-04 TICKETING VENDING MACHINE, SEE COMMUNICATIONS DESIGN DWGS
- 12-05 BEYOND, SEE URBAN DESIGN DWGS
- 12-06 KIOSK, OWNER PROVIDED
- 12-07 SMART CARD VALIDATOR, SEE URBAN DESIGN DWGS
- 12-08 VERTICAL BIKE RACK
- 12-12 VARIABLE MESSAGE SIGN, SEE COMMUNICATIONS DRAWINGS
- 12-24 LIGHT, SEE ELECTRICAL DRAWINGS
- 12-32 ETEL, SEE COMMUNICATION DRAWINGS

### MATERIAL OR TYPE KEYNOTES

- A-CONC ARCHITECTURAL CONCRETE
- MTL-M1 EXPANDED METAL MESH
- PA-2 SIGNAGE



# I-494 Crossing

## Knox Avenue Transitway

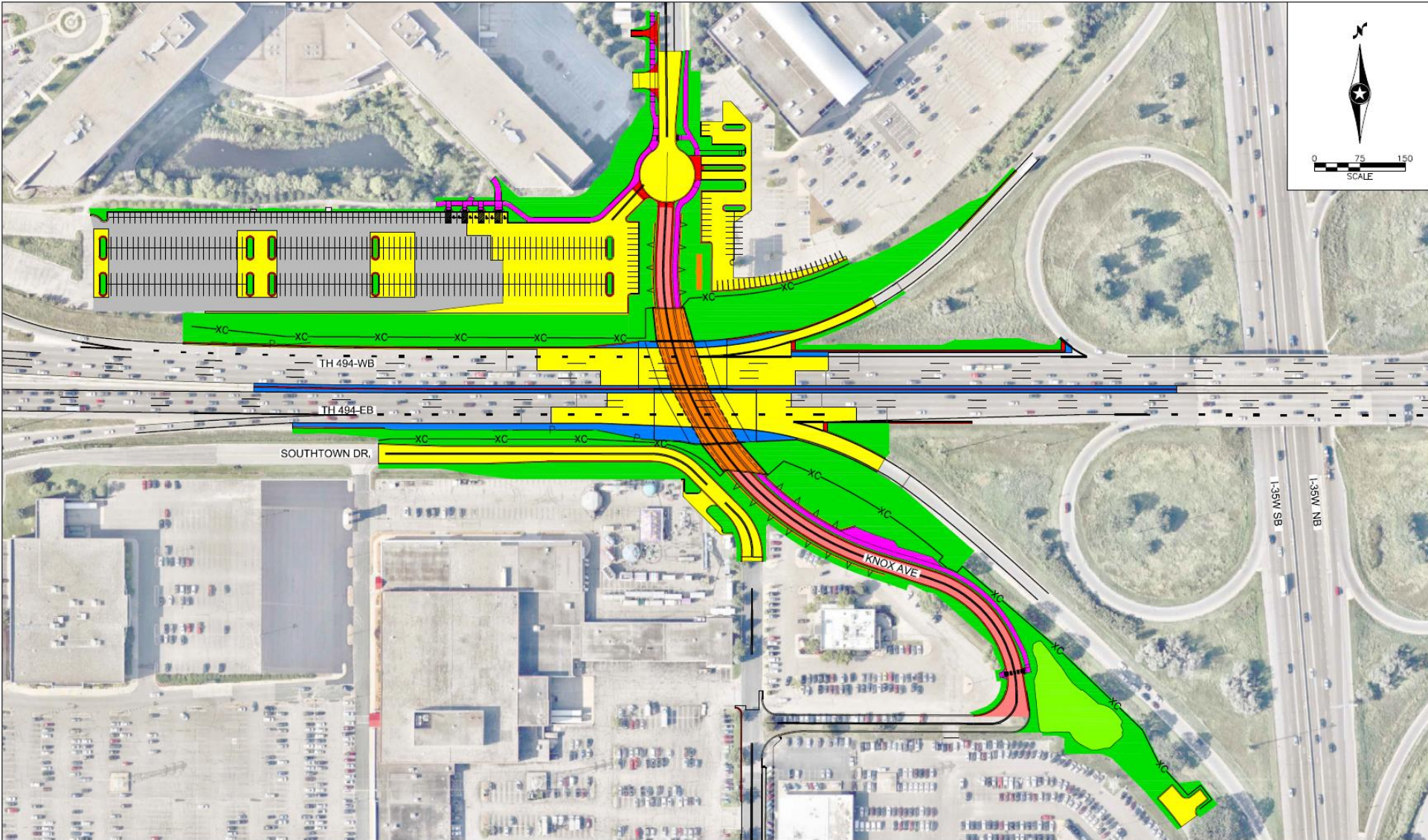

**RESOLUTION NO.**

**RESOLUTION OF SUPPORT FOR THE  
METRO ORANGE LINE BUS RAPID TRANSIT STATION  
AND KNOX AVENUE TRANSITWAY DESIGN**

**WHEREAS**, The City of Richfield's Comprehensive Plan promotes an integrated transportation system that will serve the future needs of its residents, businesses, and visitors; as well as supports the City's redevelopment plans to complement the metropolitan transportation system; and

**WHEREAS**, the City's Comprehensive Plan promotes improvement of non-motorized and pedestrian travel in the City by connecting pedestrian and bike trails to adjacent communities; and

**WHEREAS**, METRO Orange Line Bus Rapid Transit (BRT) is planned on I-35W, with BRT stations at 66<sup>th</sup> Street and Knox Avenue/76<sup>th</sup> Street with a new transitway under I-494 at Knox Avenue that would accommodate pedestrians and bicycles; and

**WHEREAS**, METRO Orange Line would enhance transit service frequency and access to both I-35W transit routes and local routes; and

**WHEREAS**, METRO Orange Line using the Knox Avenue alignment would provide the greatest benefit to Richfield residents and those working within the city; and

**WHEREAS**, METRO Orange Line station locations have been closely integrated with MnDOT's I-494/35W Interchange Vision Layout to advance and benefit both projects; and

**WHEREAS**, Metropolitan Council has completed final plans for the station design; and

**WHEREAS**, Metropolitan Council has completed the final layout for the Knox Avenue Transitway; and

**WHEREAS**, the City of Richfield has reviewed both the final station plans and transitway layout.

**NOW, THEREFORE, BE IT RESOLVED**, that the City of Richfield hereby supports:

1. The station design for the METRO Orange Line Bus Rapid Transit Project; and
2. The Knox Avenue Transitway Layout Plan for the METRO Orange Line.

Adopted by the City Council of the City of Richfield, Minnesota this 27th day of March, 2018.

---

Pat Elliott, Mayor

ATTEST:

---

Elizabeth VanHoose, City Clerk

## METRO Orange Line Bus Rapid Transit Project

- » 17-mile transitway in Small Starts Project Development
- » Region's busiest express bus corridor with 14,000 daily transit rides and over 200,000 auto vehicles/trucks
- » 12 accessible transit stations with enhanced infrastructure with all-day, reliable, frequent service
- » Access to 198,000 jobs and 121,000 residents, including 56,000 jobs outside of downtown Minneapolis
- » \$150.7 million project, all non-federal funding secured
- » FTA issued Letter of No Prejudice approval for joint MnDOT construction up to \$46.87 million
- » Construction began 2017 in coordination with MnDOT projects, remainder to follow Small Starts grant
- » \$74.1 million requested from FTA for FY18
- » Scheduled to open 2020-2021

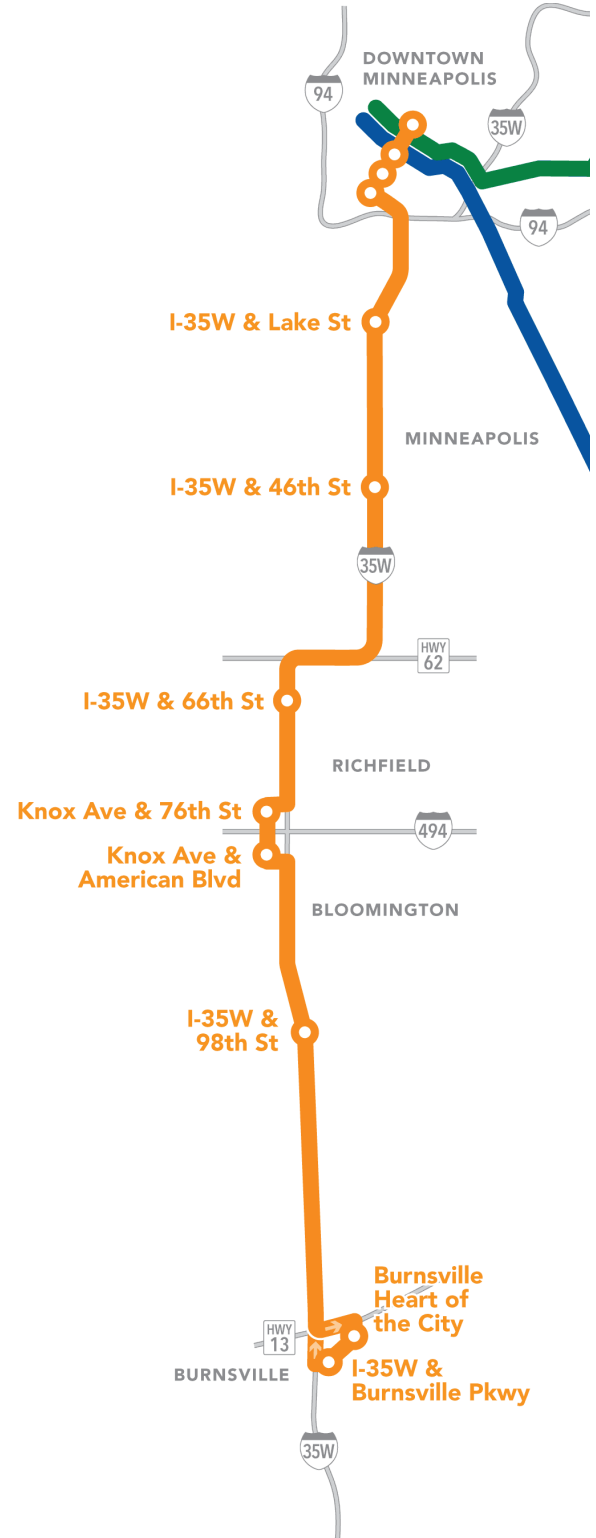



## METRO Orange Line Bus Rapid Transit Project

The METRO Orange Line Bus Rapid Transit (BRT) project will use roadway improvements, upgraded transit stations and improved bus service to provide fast, frequent and reliable all-day transit service along I-35W.

Buses will travel on Marquette and 2nd Avenues in downtown Minneapolis. South of downtown, the Orange Line will provide frequent service to stations at Lake Street, 46th Street, 66th Street, 76th Street, American Boulevard, 98th Street, Nicollet Avenue and Burnsville Parkway.

As a part of the METRO system, the Orange Line will connect people across the region to job centers, including major corridor employers such as Best Buy, Health Partners, and Toro.

Capital Sources, in Millions

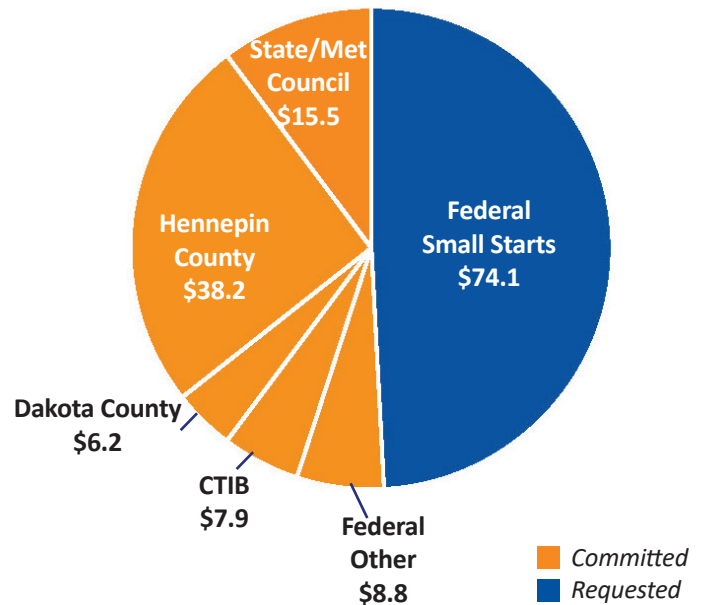



**STAFF REPORT NO. 57**  
**CITY COUNCIL MEETING**  
**3/27/2018**

REPORT PREPARED BY: Jennifer Anderson, Support Services Manager

DEPARTMENT DIRECTOR REVIEW: Jay Henthorne, Director of Public Safety/Chief of Police  
3/14/2018

OTHER DEPARTMENT REVIEW: N/A

CITY MANAGER REVIEW: Steven L. Devich, City Manager  
3/19/2018

**ITEM FOR COUNCIL CONSIDERATION:**

**Consideration of the approval of issuance of a temporary on-sale intoxicating liquor license for the Blessed Trinity Catholic School, located at the Assumption Catholic Church, 305 East 77th Street, for their 2018 Fiesta event taking place April 28, 2018.**

**EXECUTIVE SUMMARY:**

On March 1, 2018, the City received application materials for a temporary on-sale intoxicating liquor license for the Blessed Trinity Catholic School, located at the Assumption Catholic Church, 305 East 77th Street, for their 2018 Fiesta event taking place April 28, 2018. They plan to serve strong beer from 5:00 p.m. to 9:00 p.m.

Food for this event includes rice, beans, corn, tortillas and tamales. The Blessed Trinity Catholic School has contacted food sanitarians from the City of Bloomington to ensure proper food handling practices are followed.

The Director of Public Safety has reviewed all required information and documents and has found no basis for denial.

The City Council has previously granted this license in conjunction with this event.

**RECOMMENDED ACTION:**

**By motion: Approve issuance of a temporary on-sale intoxicating liquor license for the Blessed Trinity Catholic School, located at the Assumption Catholic Church, 305 East 77th Street, for their 2018 Fiesta event taking place April 28, 2018.**

**BASIS OF RECOMMENDATION:**

**A. HISTORICAL CONTEXT**

- The applicant has satisfied the following requirements for the issuance of this license:
  - The required licensing fee has been paid.
  - Proof of liquor liability insurance has been provided showing the Catholic Mutual Relief Society of America affording the coverage.



**B. POLICIES (resolutions, ordinances, regulations, statutes, etc):**

- Richfield City Code Section 1202.05 requires all applicants to comply with all of the provisions of this code, as well as the provisions of Minnesota Statute Chapter 340A.

**C. CRITICAL TIMING ISSUES:**

- There are no critical timing issues.

**D. FINANCIAL IMPACT:**

- The required licensing fees have been received.

**E. LEGAL CONSIDERATION:**

- There are no legal considerations.

**ALTERNATIVE RECOMMENDATION(S):**

- The Council could decide to deny the approval of the temporary on-sale intoxicating liquor license for the Blessed Trinity Catholic School. This would mean the applicant would not be able to serve intoxicating alcohol, wine or 3.2 percent malt liquor; however, Public Safety has not found any basis for denial.

**PRINCIPAL PARTIES EXPECTED AT MEETING:**

Blessed Trinity Catholic staff has been notified of the date of this meeting.



**STAFF REPORT NO. 58**  
**CITY COUNCIL MEETING**  
**3/27/2018**

REPORT PREPARED BY: Wayne Kewitsch, Fire Chief

DEPARTMENT DIRECTOR REVIEW: Wayne Kewitsch, Fire Chief  
3/16/2018

OTHER DEPARTMENT REVIEW: N/A

CITY MANAGER REVIEW: Steven L. Devich, City Manager  
3/19/2018

**ITEM FOR COUNCIL CONSIDERATION:**

**Consideration of the approval of a resolution allowing acceptance of a grant for the Fire Department to purchase lifting safety equipment.**

**EXECUTIVE SUMMARY:**

The Fire Department applied for, and was awarded, a grant from the Minnesota Department of Labor & Industry to purchase safety equipment to minimize back injuries from lifting patients. The Fire Department currently has two ELK lift assist devices and this grant will allow them to purchase a third device such that all front-line apparatus will be equipped with the equipment.

**RECOMMENDED ACTION:**

**By motion: Approve a resolution allowing the acceptance of the grant for the Fire Department to purchase lifting safety equipment.**

**BASIS OF RECOMMENDATION:**

**A. HISTORICAL CONTEXT**

- The Fire Department works to find grants that will assist the Department complete its mission and offset costs to the City.

**B. POLICIES (resolutions, ordinances, regulations, statutes, etc):**

- Minnesota Statute 465.03 requires every acceptance of a grant or devise of real or personal property on terms prescribed by the donor be made by resolution and adopted by two-thirds majority of the City Council.
- The Administrative Services Department issued a memo on November 9, 2004 requiring that all grants and restricted donations to departments be received by resolution and adopted by two-thirds majority of the City Council in accordance with Minnesota Statute 465.03.

**C. CRITICAL TIMING ISSUES:**

- The grant has been awarded to the Fire Department by the Minnesota Department of Labor & Industry.
- Council must accept the grant by resolution prior to the funds being disbursed.

**D. FINANCIAL IMPACT:**

- The grant is for 50% of the cost of an ELK lifting device.
- The grant is contingent on the awardee providing a 50% match.
- The Department has funds budgeted to meet the required match.
- The grant amount is estimated to be \$1,169.00.

**E. LEGAL CONSIDERATION:**

- Minnesota Statute 465.03 requires every acceptance of a grant or devise of real or personal property be received by resolution and adopted by two-thirds majority of the City Council.

**ALTERNATIVE RECOMMENDATION(S):**

- Should Council not accept the grant, the Department would need to locate an alternate funding source to cover the grant amount.

**PRINCIPAL PARTIES EXPECTED AT MEETING:**

None

**ATTACHMENTS:**

	Description	Type
□	Resolution	Resolution Letter

**RESOLUTION NO.**

**RESOLUTION AUTHORIZING THE ACCEPTANCE OF A  
GRANT FROM THE MINNESOTA DEPARTMENT OF LABOR  
AND INDUSTRY FOR THE RICHFIELD FIRE DEPARTMENT TO  
LIFTING SAFETY EQUIPMENT**

**WHEREAS**, the Richfield Fire Department applied for and was awarded a grant to purchase lifting safety devices from the Minnesota Department of Labor and Industry; and,

**WHEREAS**, the Richfield Fire Department has designated the \$1,169.00 to be used to purchase the equipment.

**NOW, THEREFORE, BE IT RESOLVED**, by the City Council of the City of Richfield, Minnesota, that the Fire Chief will accept funds designated for the purchase of lifting safety equipment in accordance to and as listed above.

Adopted by the City Council of the City of Richfield, Minnesota this 27th day of March, 2018.

---

Pat Elliott, Mayor

ATTEST:

---

Elizabeth VanHoose, City Clerk



**STAFF REPORT NO. 59**  
**CITY COUNCIL MEETING**  
**3/27/2018**

REPORT PREPARED BY: Wayne Kewitsch, Fire Chief

DEPARTMENT DIRECTOR REVIEW: Wayne Kewitsch, Fire Chief  
3/20/2018

OTHER DEPARTMENT REVIEW: N/A

CITY MANAGER REVIEW: Steven L. Devich, City Manager  
3/21/2018

**ITEM FOR COUNCIL CONSIDERATION:**

**Consideration of the approval of the purchase of a station alerting system from U.S. Digital Designs in the amount of \$114,500 for both Richfield fire stations.**

**EXECUTIVE SUMMARY:**

A station alerting system is a system of hardware and software that automates a number of processes that are currently performed manually by a dispatcher. The system integrates with the dispatch software to alert firefighters of the nature and location of the call while the dispatcher is still taking information from the reporting party. This results in earlier responder notification which leads to a faster response to the incident. An added benefit is that it increases dispatcher productivity resulting in their ability to handle higher call volumes. This system is being purchased in coordination with Edina Fire and Edina 911 Communications; this purchase will also lead to added efficiencies between the two fire departments during automatic aid response.

**RECOMMENDED ACTION:**

**By motion: Approve the purchase of a station alerting system from U.S. Digital Designs in the amount of \$114,500 for both Richfield fire stations.**

**BASIS OF RECOMMENDATION:**

**A. HISTORICAL CONTEXT**

- The number of incidents the Fire Department responds to has been steadily increasing and now surpasses 4,000 calls for service annually. The increased call volume puts pressure on the system to maintain high levels of service.
- Automated station alerting has been proven to decrease turnout times which results in faster response times.
- Historically, Edina Fire has been our longest standing aid partner. This system will allow us to implement additional operational efficiencies that will benefit both departments and their respective communities.
- Systems from U.S. Digital Designs are currently installed in Minnesota in Dakota and Ramsey counties, department personnel reviewed their operation and they were recommended by fire department personnel in the respective counties.

**B. POLICIES (resolutions, ordinances, regulations, statutes, etc):**

- City policy regarding purchasing and spending requires any purchases greater than \$100,000 be approved by the City Council. Additionally, Minnesota Statute 471.345, Uniform Municipal Contracting law, states that all purchases greater than \$100,000 be made by sealed bid, via public notice and awarded to the lowest responsible bidder. This statute also allows for purchasing via state awarded contracts or other governmental purchasing consortiums or cooperatives.
- U.S. Digital Designs is an awarded and approved vendor of the Houston-Galveston Area Council Purchasing Consortium (HGACBuy). The City is a member of HGACBuy and can take advantage of contracts and vendors that are members of the consortium, including U.S. Digital Designs.

**C. CRITICAL TIMING ISSUES:**

- The purchase of the station alerting system is included in the 2018 Fire Department budget.
- The system is being purchased in coordination with the Edina Fire Department and Edina Emergency Communications. This purchase is on the agenda for approval at the next Edina City Council meeting. Approval now would allow both cities to move forward with a coordinated system implementation.

**D. FINANCIAL IMPACT:**

- The funds to purchase this equipment are being provided through an internal lease via the Capital Improvement Reserve Fund.

**E. LEGAL CONSIDERATION:**

- A legally compliant purchasing process was followed by HGACBuy resulting in U.S. Digital Designs being an approved and awarded vendor of their purchasing consortium.
- The City is a member of HGACBuy and is allowed to take advantage of purchasing via the consortium.

**ALTERNATIVE RECOMMENDATION(S):**

- None

**PRINCIPAL PARTIES EXPECTED AT MEETING:**

None



**STAFF REPORT NO. 60**  
**CITY COUNCIL MEETING**  
**3/27/2018**

REPORT PREPARED BY: Jared Voto, Executive Aide/Analyst

DEPARTMENT DIRECTOR REVIEW: Steven L. Devich, City Manager  
3/21/2018

OTHER DEPARTMENT REVIEW: N/A

CITY MANAGER REVIEW: Steven L. Devich, City Manager  
3/21/2018

**ITEM FOR COUNCIL CONSIDERATION:**

**Consideration of the approval of a resolution appointing Bryan Kuffel to the Richfield Tourism Promotion Board to complete a three-year term ending December 31, 2018, or until a successor is chosen, whichever is later.**

**EXECUTIVE SUMMARY:**

On June 25, 1990 the City Council approved an ordinance to levy a 3% tax on gross receipts of lodging from Richfield Hotels and Motels pursuant to Minnesota Statutes. The establishment of the Richfield Tourism Promotion Board, Inc. (RTPB) and the appointment of directors was also a part of the resolution. Currently, there are five director positions on the RTPB. The term of each appointment is for three years.

The current appointments to the RTPB and the ending dates of their terms are as follows:

1. Gordon Vizecky, representing the Richfield Chamber of Commerce, term ending on December 31, 2019.
2. Raj Bhakta, General Manager of Baymont Suites, term ending December 31, 2018.
3. Adam Selby, General Manager of Four Points by Sheraton, term ending December 31, 2018.
4. Vacant, Representative of Candlewood Suites.
5. Vacant, Representative of Motel 6.

**RECOMMENDED ACTION:**

**By motion: Adopt a resolution appointing Bryan Kuffel to the Richfield Tourism Promotion Board, Inc. to complete a three-year term ending December 31, 2018 or until a successor is chosen, whichever is later.**

**BASIS OF RECOMMENDATION:**

**A. HISTORICAL CONTEXT**

- This information is contained in the Executive Summary.

**B. POLICIES (resolutions, ordinances, regulations, statutes, etc):**

- The City Council has the authority to make appointments to the RTPB.
- The RTPB has typically included a representative from each of the hotel properties and a member of the Richfield Chamber of Commerce.

**C. CRITICAL TIMING ISSUES:**

- The Candlewood Suites position on the RTPB is now vacant so the appointment of the Director of Sales should be made as soon as possible.

**D. FINANCIAL IMPACT:**

- There is no cost to the City.

**E. LEGAL CONSIDERATION:**

- The appointment conforms to City ordinance and bylaws of the RTPB.

**ALTERNATIVE RECOMMENDATION(S):**

- The City Council could decide not to make this appointment to the RTPB.
- The City Council could choose to review this matter at a future date.

**PRINCIPAL PARTIES EXPECTED AT MEETING:**

None

**ATTACHMENTS:**

	Description	Type
▢	Resolution	Resolution Letter
▢	Nomination Letter	Backup Material



**RESOLUTION NO.**

**RESOLUTION APPOINTING A REPRESENTATIVE TO THE  
BOARD OF DIRECTORS OF THE RICHFIELD TOURISM  
PROMOTION BOARD, INC.**

**WHEREAS**, the City of Richfield has levied a 3% tax on the gross receipts of lodging from hotels and motels in the City pursuant to Minnesota Statute Section 169.190; and

**WHEREAS**, Minnesota Statute Section 169.190 authorizes the proceeds of the tax to fund a Tourism Promotion Board for the purpose of marketing and promoting the City as a tourist or convention center; and

**WHEREAS**, the articles and bylaws of the Richfield Tourism Promotion Board, Inc. provide the City Council of the City of Richfield appoint five (5) directors to the Board representing the Richfield hotel-motel properties and the Richfield Chamber of Commerce; and

**WHEREAS**, each director shall serve as a director until his or her successor has been appointed and has qualified, or until his or her earlier disqualification, death, resignation, or removal; and

**WHEREAS**, the term of the following hotel representative has been vacant and a new representative has indicated a desire to be appointed to the Richfield Tourism Promotion Board:

- **Bryan Kuffel**, Director of Sales of Candlewood Suites

**NOW, THEREFORE, BE IT RESOLVED**, by the City Council of the City of Richfield, Minnesota, that the Richfield Tourism Promotion Board directors be modified as follows:

Appoint the following hotel representative to the Richfield Tourism Promotion Board to complete a three-year term:

- **Bryan Kuffel**, Director of Sales of Candlewood Suites, term ending December 31, 2018.

Adopted by the City Council of the City of Richfield, Minnesota this 27th day of March, 2018.

---

Pat Elliott, Mayor

ATTEST:

---

Elizabeth VanHoose, City Clerk

## Jared Voto

---

**From:** Bain, Whitney <Whitney.Bain@ihg.com>  
**Sent:** Wednesday, March 21, 2018 11:14 AM  
**To:** Jared Voto  
**Subject:** Candlewood Suites Richfield

Good Afternoon Jared,

Bryan Kuffel will be the Candlewood Suites Representative on the Richfield Tourism board moving for Candlewood Suites here in Richfield MN.

Please let me know if you need anything further from me.

Yours in hospitality,

**Whitney Bain**  
General Manager

**Candlewood Suites Richfield Minneapolis - IHG**

351 W 77th St, Richfield, MN 55423

Tel: 612.869.7704 Mobile: 970.776.6811

[IHG®](#) | [Book IHG](#) | [Join IHG](#) | [LinkedIn](#) | [Facebook](#) | [Twitter](#)





**STAFF REPORT NO. 61**  
**CITY COUNCIL MEETING**  
**3/27/2018**

REPORT PREPARED BY: Matt Brillhart, Associate Planner

DEPARTMENT DIRECTOR REVIEW: Melissa Poehlman, Assistant Community Development Director  
3/20/2018

OTHER DEPARTMENT REVIEW: N/A

CITY MANAGER REVIEW: Steven L. Devich, City Manager  
3/21/2018

**ITEM FOR COUNCIL CONSIDERATION:**

**Public hearing and consideration of the approval of a resolution for a preliminary plat of "Nora Corner" that will combine four parcels (6529 and 6545 Penn Avenue, and 2208 and 2210 66th Street West) into three parcels, in order to allow construction of a previously approved restaurant (Dunkin Donuts).**

**EXECUTIVE SUMMARY:**

The City Council approved land use plans for a Dunkin Donuts restaurant at 6529 Penn Avenue, including improvements to the adjacent property at 6545 Penn Avenue, on October 24, 2017. The applicant (Penn Avenue Partners II, LLC) owns four contiguous parcels at the northeast corner of 66th Street and Penn Avenue, all of which are unplatted land. They are now proposing to plat and combine that land into three parcels. These parcels would correspond to the Dunkin Donuts at 6529 Penn Avenue, the former Flowerama building at 6545 Penn Avenue, and the Aida restaurant at 2208 66th Street West.

The proposed plat of "Nora Corner" has been reviewed by the City Attorney's Office, Richfield Public Works, and Hennepin County. Prior to consideration of a final plat application, the applicant will be required to satisfactorily address all comments. No major issues are anticipated.

**RECOMMENDED ACTION:**

**Conduct and close a public hearing and by motion: Approve the resolution for a preliminary plat of "Nora Corner" that will combine four parcels (6529 and 6545 Penn Avenue, and 2208 and 2210 66th Street West) into three parcels, in order to allow construction of a previously approved restaurant (Dunkin Donuts).**

**BASIS OF RECOMMENDATION:**

A. **HISTORICAL CONTEXT**

- None

B. **POLICIES (resolutions, ordinances, regulations, statutes, etc):**

- All plats or subdivisions of land must be approved by City Council resolution, pursuant to the provisions of Minnesota State Statutes 462.357.

C. **CRITICAL TIMING ISSUES:**

- Per State Statute, the City has 120 days from the date of submittal of a complete application to

issue a decision regarding plat unless the applicant agrees to an extension.

- A complete application was received on February 5, 2018. The Council must render a decision by June 5, 2018.

**D. FINANCIAL IMPACT:**

- None

**E. LEGAL CONSIDERATION:**

- Notice of this public hearing was published in the Richfield Sun Current newspaper.

**ALTERNATIVE RECOMMENDATION(S):**

- None

**PRINCIPAL PARTIES EXPECTED AT MEETING:**

Karla Carlson, Capital Real Estate, Inc.

**ATTACHMENTS:**

	Description	Type
▢	Resolution	Resolution Letter
▢	Plat	Backup Material

**RESOLUTION NO.**

**RESOLUTION GRANTING PRELIMINARY APPROVAL  
OF A PLAT FOR  
CEDAR POINT COMMONS SECOND ADDTION**

**WHEREAS**, Penn Avenue Partners II, LLC (“Applicant”) has requested preliminary approval of a plat that combines and resubdivides properties located at 6529 Penn Avenue, 6545 Penn Avenue, 2208 66th Street West and 2210 66th Street West, legally described in the attached Exhibit A; and

**WHEREAS**, the proposed subdivision is to be known as NORA CORNER; and

**WHEREAS**, a public hearing was held on the proposed preliminary plat of NORA CORNER on Tuesday, March 27, 2018 at which all interested persons were given the opportunity to be heard; and

**NOW, THEREFORE, BE IT RESOLVED** by the City Council of the City of Richfield, as follows:

1. The proposed preliminary plat of NORA CORNER satisfies the requirements of the City’s subdivision ordinances.
2. Approval of the preliminary plat of NORA CORNER is granted with the following conditions:
  - a. The applicant must address to the City Attorney’s satisfaction all items listed in the plat opinion letter prepared by the City Attorney’s office.
  - b. The applicant must address any/all comments by the City Engineering Department and Hennepin County.
  - c. The Applicant must apply for final approval once construction of improvements has been completed or construction of said improvements has been secured by contract and bond.
  - d. The Applicant must submit a completed application for final plat within one year of preliminary plat approval.

Adopted by the City Council of the City of Richfield, Minnesota this 27th day of March, 2018.

\_\_\_\_\_  
Pat Elliott, Mayor

ATTEST:

\_\_\_\_\_  
Elizabeth VanHoose, City Clerk

## EXHIBIT A

### DESCRIPTION OF PROPERTY SURVEYED

(Per Certificate of Title No. 1195401)

Parcel 1:

That part of the West 166 feet of the Southwest Quarter of the Southwest Quarter of the Southwest Quarter of the Northwest Quarter of Section 28, Township 28, Range 24, lying North of the South 175 feet thereof; and  
The North 17 feet of the South 175 feet of the West 133 feet of the Southwest Quarter of the Southwest Quarter of the Southwest Quarter of the Northwest Quarter of Section 28, Township 28, Range 24, in the Village of Richfield, Hennepin County, Minnesota.

Parcel 2:

The East 20 feet of the West 153 feet of the South 175 feet of the Southwest Quarter of the Southwest Quarter of the Southwest Quarter of the Northwest Quarter of Section 28, Township 28, Range 24, in the Village of Richfield, Hennepin County, Minnesota.

Parcel 3:

The South 158 feet of the West 133 feet of the Southwest Quarter of the Southwest Quarter of the Southwest Quarter of the Northwest Quarter of Section 28, Township 28, Range 24.

Subject to the right of way of Penn Avenue South over the Westerly 33 feet thereof, as shown in deed Doc. No. 851523; (as to Parcel 1)

Subject to the right of way of West 66th Street over the Southerly 33 feet thereof, as shown in deed Doc. No. 851523; (as to Par 2)

AND

(Per Certificate of Title No. 1195402)

That part of the South 175 feet of the Southwest Quarter of the Southwest Quarter of the Southwest Quarter of the Northwest Quarter of Section 28, Township 28, Range 24, lying East of the West 153 feet thereof and lying West of the East 70 feet thereof, in the Village of Richfield, Hennepin County, Minnesota.

Subject to the right of way of West 66th Street over the Southerly 33 feet of the premises, as shown in deed Doc No. 1089259;

# NORA CORNER

R.T. DOC. NO. \_\_\_\_\_

KNOW ALL PERSONS BY THESE PRESENTS: That Penn Avenue Partners II, LLC, a Delaware limited liability company, owner and proprietor of the following described property situated in the County of Hennepin, State of Minnesota, to wit:

That part of the West 166 feet of the Southwest Quarter of the Southwest Quarter of the Southwest Quarter of the Northwest Quarter of Section 28, Township 28, Range 24, lying North of the South 175 feet thereof;

AND

The North 17 feet of the South 175 feet of the West 133 feet of the Southwest Quarter of the Southwest Quarter of the Southwest Quarter of the Northwest Quarter of Section 28, Township 28, Range 24, in the Village of Richfield, Hennepin County, Minnesota.

AND

The East 20 feet of the West 153 feet of the South 175 feet of the Southwest Quarter of the Southwest Quarter of the Southwest Quarter of the Northwest Quarter of Section 28, Township 28, Range 24, in the Village of Richfield, Hennepin County, Minnesota.

AND

The South 158 feet of the West 133 feet of the Southwest Quarter of the Southwest Quarter of the Southwest Quarter of the Northwest Quarter of Section 28, Township 28, Range 24.

AND

That part of the South 175 feet of the Southwest Quarter of the Southwest Quarter of the Southwest Quarter of the Northwest Quarter of Section 28, Township 28, Range 24, lying East of the West 153 feet thereof and lying West of the East 70 feet thereof, in the Village of Richfield, Hennepin County, Minnesota.

Has caused the same to be surveyed and platted as NORA CORNER and does hereby dedicate to the public, for public use the public ways and the drainage and utility easements as created by this plat.

In witness whereof said Penn Avenue Partners II, LLC, a Delaware limited liability company, has caused these presents to be signed by its proper officer this \_\_\_\_\_ day of \_\_\_\_\_, 20\_\_\_\_.

SIGNED: \_\_\_\_\_ its \_\_\_\_\_

STATE OF \_\_\_\_\_

COUNTY OF \_\_\_\_\_

The foregoing instrument was acknowledged before me this \_\_\_\_\_ day of \_\_\_\_\_, 20\_\_\_\_, by \_\_\_\_\_ the \_\_\_\_\_, of Penn Avenue Partners II, LLC, a Delaware limited liability company, on behalf of said company.

\_\_\_\_\_  
\_\_\_\_\_

Notary Public, \_\_\_\_\_ County, \_\_\_\_\_

My Commission Expires: \_\_\_\_\_

I, Arlee J. Carlson, do hereby certify that this plat was prepared by me or under my direct supervision; that I am a duly Licensed Land Surveyor in the State of Minnesota; that this plat is a correct representation of the boundary survey; that all mathematical data and labels are correctly designated on the plat; that all monuments depicted on the plat have been, or will be correctly set within one year; that all water boundaries and wet lands as defined in Minnesota Statutes, Section 505.01, Subd. 3, as of the date of this certificate are shown and labeled on this plat; and all public ways are shown and labeled on this plat.

Dated this \_\_\_\_\_ day of \_\_\_\_\_, 20\_\_\_\_.

\_\_\_\_\_  
Arlee J. Carlson, Licensed Land Surveyor  
Minnesota License No. 44900

STATE OF MINNESOTA  
COUNTY OF HENNEPIN

This instrument was acknowledged before me on this \_\_\_\_\_ day of \_\_\_\_\_, 20\_\_\_\_, by Arlee J. Carlson.

\_\_\_\_\_  
\_\_\_\_\_

Notary Public, \_\_\_\_\_ County, Minnesota

My Commission Expires \_\_\_\_\_

RICHFIELD, MINNESOTA

This plat of NORA CORNER was approved and accepted by the City Council of Richfield, Minnesota, at a regular meeting thereof held this \_\_\_\_\_ day of \_\_\_\_\_, 20\_\_\_\_. If applicable, the written comments and recommendations of the Commissioner of Transportation and the County Highway Engineer have been received by the City or the prescribed 30 day period has elapsed without receipt of such comments and recommendations, as provided by Minn. Statutes, Section 505.03, Subd. 2.

CITY COUNCIL OF RICHFIELD, MINNESOTA

BY: \_\_\_\_\_ Mayor

BY: \_\_\_\_\_ Manager

RESIDENT AND REAL ESTATE SERVICES, Hennepin County, Minnesota

I hereby certify that taxes payable in 20\_\_\_\_ and prior years have been paid for land described on this Plat, dated this \_\_\_\_\_ day of \_\_\_\_\_, 20\_\_\_\_.

Mark V. Chapin, Hennepin County Auditor

BY: \_\_\_\_\_ Deputy

SURVEY DIVISION, Hennepin County, Minnesota

Pursuant to Minnesota Statutes, Sec. 383B.565 (1969), this plat has been approved this \_\_\_\_\_ day of \_\_\_\_\_, 20\_\_\_\_.

Chris F. Mavis, County Surveyor

BY: \_\_\_\_\_

REGISTRAR OF TITLES, Hennepin County, Minnesota

I hereby certify that the within plat of NORA CORNER was filed in this office this \_\_\_\_\_ day of \_\_\_\_\_, 20\_\_\_\_ at \_\_\_\_\_ o'clock \_\_\_\_M.

Martin McCormick, Registrar of Titles

BY: \_\_\_\_\_ Deputy

# NORA CORNER

R.T. DOC. NO. \_\_\_\_\_

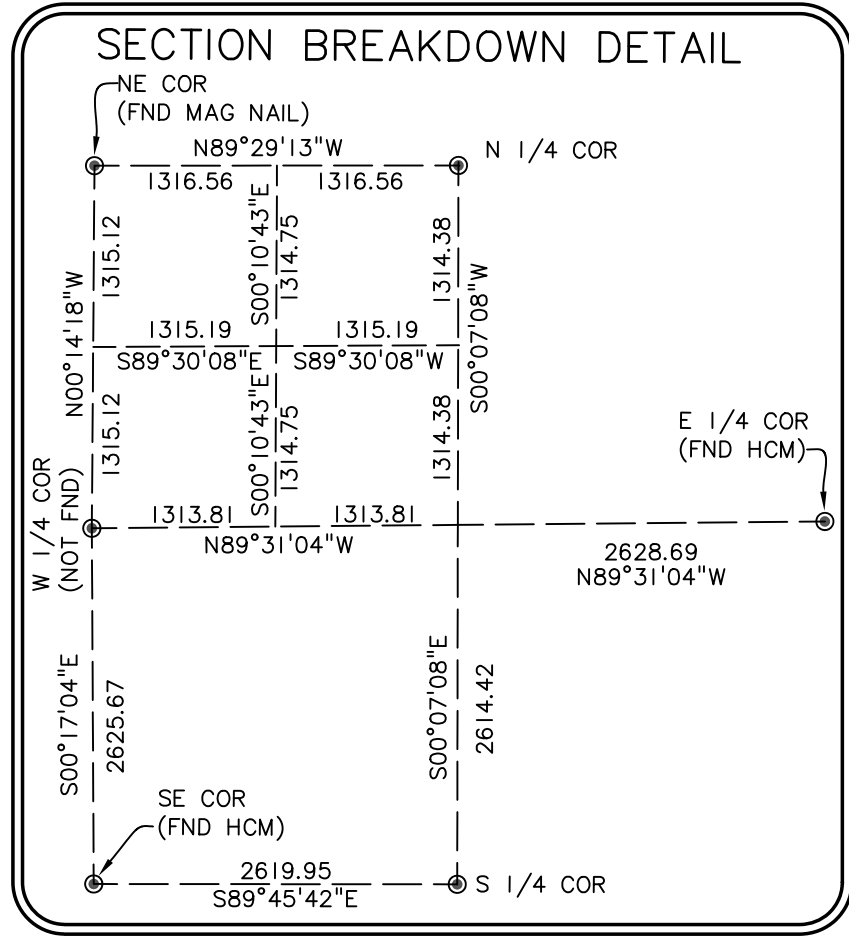
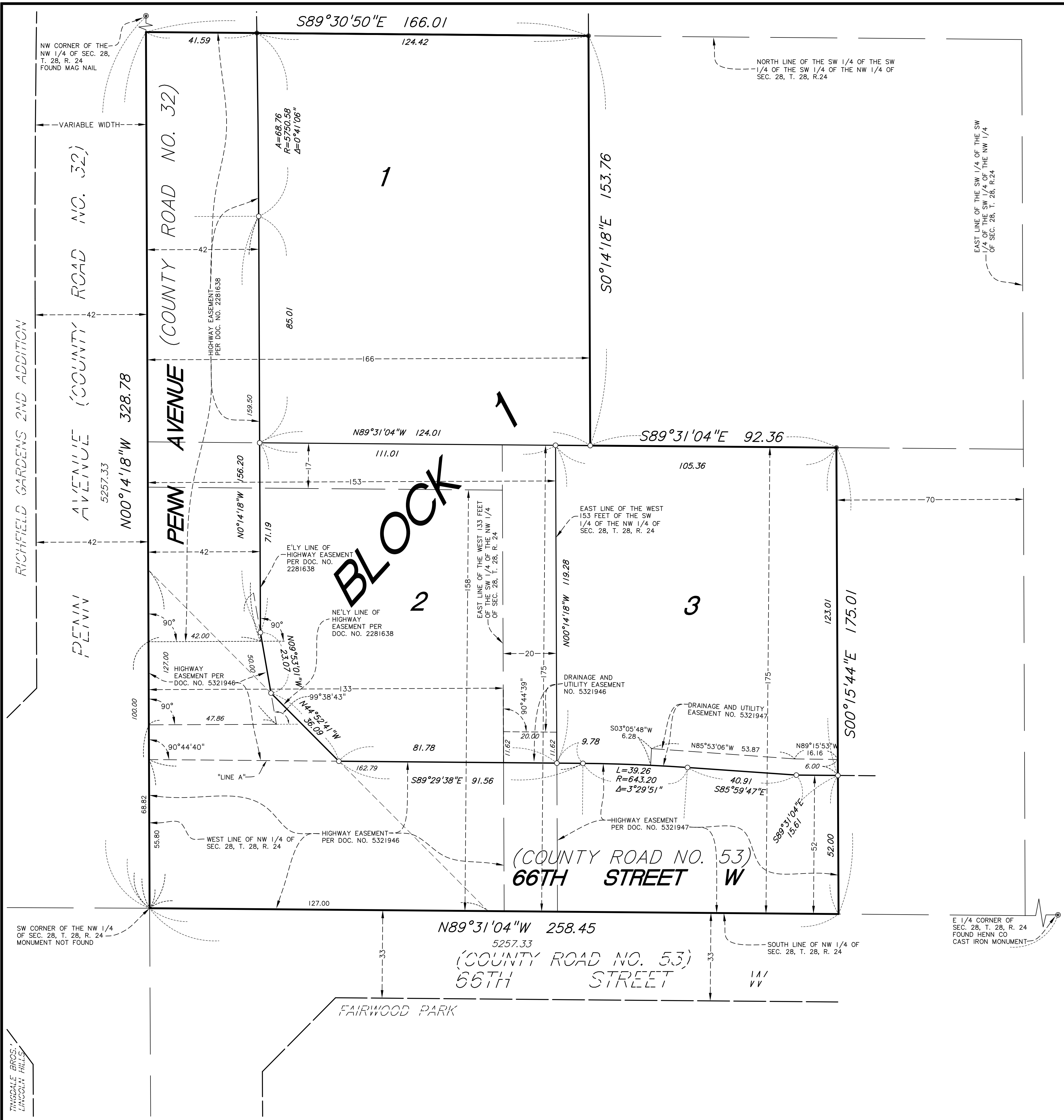

○ Denotes iron monument set, marked with PLS 44900.  
 ● Denotes iron monument found.  
 FOR THE PURPOSES OF THIS PLAT, THE SOUTH LINE OF THE NW 1/4 OF SEC. 28, T. 28, R. 24 IS ASSUMED TO BEAR  $N89^\circ 31' 04'' W$

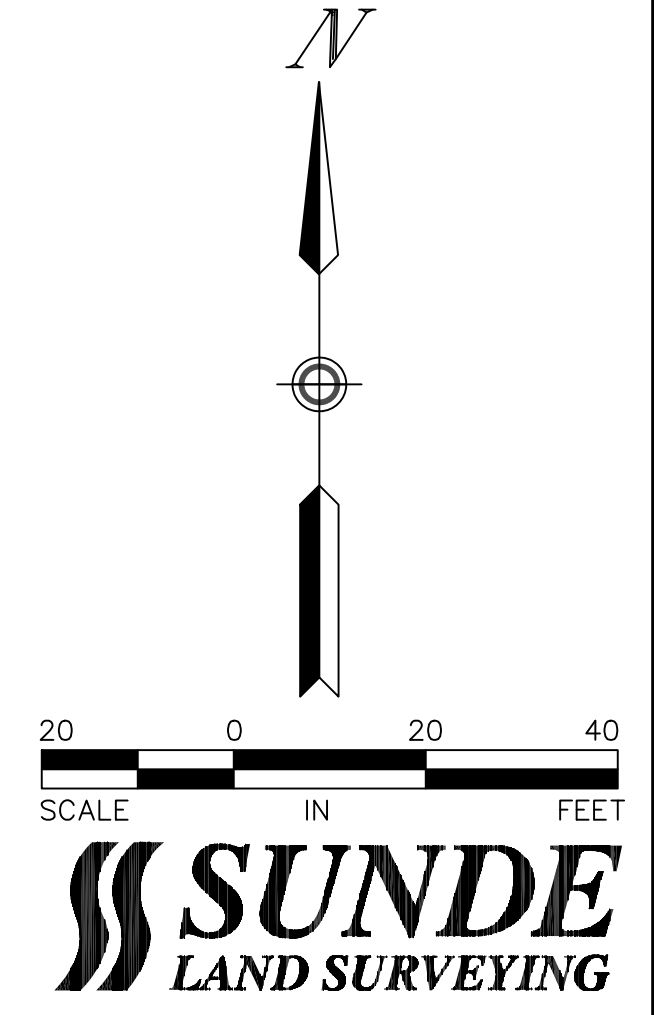



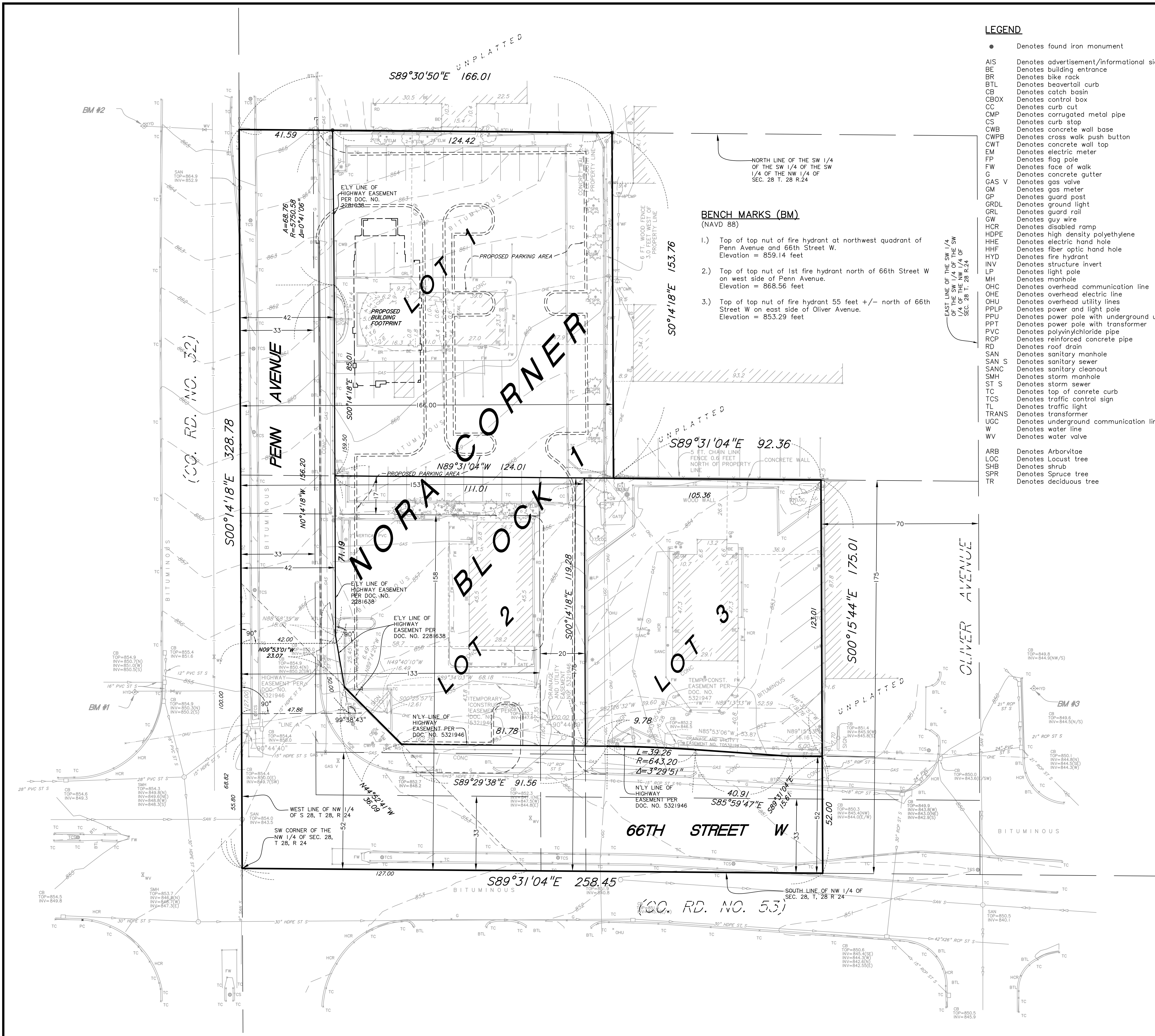

**LEGEND**

- Denotes found iron monument
- AIS Denotes advertisement/informational sign
- BE Denotes building entrance
- BR Denotes bike rack
- BTL Denotes beavertail curb
- CB Denotes catch basin
- CBOX Denotes control box
- CC Denotes curb cut
- CMP Denotes corrugated metal pipe
- CS Denotes curb stop
- CWB Denotes concrete wall base
- CWPB Denotes cross walk push button
- CWT Denotes concrete wall top
- EM Denotes electric meter
- FP Denotes flag pole
- FW Denotes face of walk
- G Denotes concrete gutter
- GAS V Denotes gas valve
- GM Denotes gas meter
- GP Denotes guard post
- GRDL Denotes ground light
- GRL Denotes guard rail
- GW Denotes guy wire
- HCR Denotes disabled ramp
- HDPE Denotes high density polyethylene
- HHE Denotes electric hand hole
- HHF Denotes fiber optic hand hole
- HYD Denotes fire hydrant
- INV Denotes structure invert
- LP Denotes light pole
- MH Denotes manhole
- OHC Denotes overhead communication line
- OHE Denotes overhead electric line
- OHU Denotes overhead utility lines
- PPLP Denotes power and light pole
- PPU Denotes power pole with underground utility
- PPT Denotes power pole with transformer
- PVC Denotes polyvinylchloride pipe
- RCP Denotes reinforced concrete pipe
- RD Denotes roof drain
- SAN Denotes sanitary manhole
- SAN S Denotes sanitary sewer
- SANC Denotes sanitary cleanout
- SMH Denotes storm manhole
- ST S Denotes storm sewer
- TC Denotes top of concrete curb
- TCS Denotes traffic control sign
- TL Denotes traffic light
- TRANS Denotes transformer
- UGC Denotes underground communication line
- W Denotes water line
- WV Denotes water valve
- ARB Denotes Arborvitae
- LOC Denotes Locust tree
- SHB Denotes shrub
- SPR Denotes Spruce tree
- TR Denotes deciduous tree

**DESCRIPTION OF PROPERTY SURVEYED**  
(Per Certificate of Title No. 1195401)

Parcel 1:  
That part of the West 166 feet of the Southwest Quarter of the Southwest Quarter of the Southwest Quarter of the Northwest Quarter of Section 28, Township 28, Range 24, lying North of the South 175 feet thereof; and  
The North 17 feet of the South 175 feet of the West 133 feet of the Southwest Quarter of the Southwest Quarter of the Northwest Quarter of Section 28, Township 28, Range 24, in the Village of Richfield, Hennepin County, Minnesota.

Parcel 2:  
The East 20 feet of the West 153 feet of the South 175 feet of the Southwest Quarter of the Southwest Quarter of the Northwest Quarter of Section 28, Township 28, Range 24, in the Village of Richfield, Hennepin County, Minnesota.

Parcel 3:  
The South 158 feet of the West 133 feet of the Southwest Quarter of the Southwest Quarter of the Southwest Quarter of the Northwest Quarter of Section 28, Township 28, Range 24.

Subject to the right of way of Penn Avenue South over the Westerly 33 feet thereof, as shown in deed Doc. No. 851523; (as to Parcel 1)  
Subject to the right of way of West 66th Street over the Southerly 33 feet thereof, as shown in deed Doc. No. 851523; (as to Parcel 2)

AND  
(Per Certificate of Title No. 1195402)

That part of the South 175 feet of the Southwest Quarter of the Southwest Quarter of the Southwest Quarter of the Northwest Quarter of Section 28, Township 28, Range 24, lying East of the West 153 feet thereof and lying West of the East 70 feet thereof, in the Village of Richfield, Hennepin County, Minnesota.

Subject to the right of way of West 66th Street over the Southerly 33 feet of the premises, as shown in deed Doc No. 1089259;

**TITLE COMMITMENT**

This survey was prepared without the benefit of current title work. Easements, appurtenances, and encumbrances may exist in addition to those shown hereon. This survey is subject to revision upon receipt of a current title insurance commitment or attorney's title opinion.

**GENERAL NOTES**

- 1.) Survey coordinate basis: Hennepin County Coordinate System NAD 83 (1986)
- 2.) There were no wetland delineation markers observed in the process of conducting the fieldwork.

**UTILITY NOTES**

- 1.) Utility information from plans and markings was combined with observed evidence of utilities to develop a view of the underground utilities shown hereon. However, lacking excavation, the exact location of underground features cannot be accurately, completely and reliably depicted. In addition, Gopher State One Call locate requests from surveyors may be ignored or result in an incomplete response. Where additional or more detailed information is required, excavation and/or a private utility locate request may be necessary.
- 2.) Other underground utilities of which we are unaware may exist. Verify all utilities critical to construction or design.
- 3.) Some underground utility locations are shown as marked onsite by those utility companies whose locators responded to our Gopher State One Call, ticket numbers 173351277, 173351280, 173351287 & 173351293.
- 4.) Contact GOPHER STATE ONE CALL at 651-454-0002 (800-252-1166) for precise onsite location of utilities prior to any excavation.

**AREAS**

Proposed Lot 1 = 19,076 square feet or 0.438 acres  
Proposed Lot 2 = 12,774 square feet or 0.293 acres  
Proposed Lot 3 = 12,745 square feet or 0.293 acres  
Right of Way = 26,152 square feet or 0.600 acres  
Gross Area = 70,747 square feet or 1.624 acres

**OWNER AND SUBDIVIDER**

Penn Avenue Partners II LLC  
50 South Sixth Street, Suite 1480  
Minneapolis, MN 55402  
Contact: Karla R. Carlson  
Phone: 612-313-0129

I hereby certify that this survey, plan, or report was prepared by me or under my direct supervision and that I am a duly Licensed Land Surveyor under the laws of the State of Minnesota.

Dated this 29th day of December, 2017  
SUNDE LAND SURVEYING, LLC.  
By: *Arlene J. Carlson*  
Arlene J. Carlson, P.L.S. Minn. Lic. No. 94900

Revision	By	Date

Drawing Title: **PRELIMINARY PLAT OF NORA CORNER**

**SUNDE LAND SURVEYING** Main Office: 9001 East Bloomington Freeway (35W) • Suite 118  
Bloomington, Minnesota 55420-3435  
952-891-2455 (Fax: 952-899-9526)  
www.sunde.com

Project: 2017-227 Bk/Pg: 650/61 Date: 12/29/2017  
Township: 28 Range: 24 Section: 28 Sheet: 1 of 1  
File: 2017227001.dwg

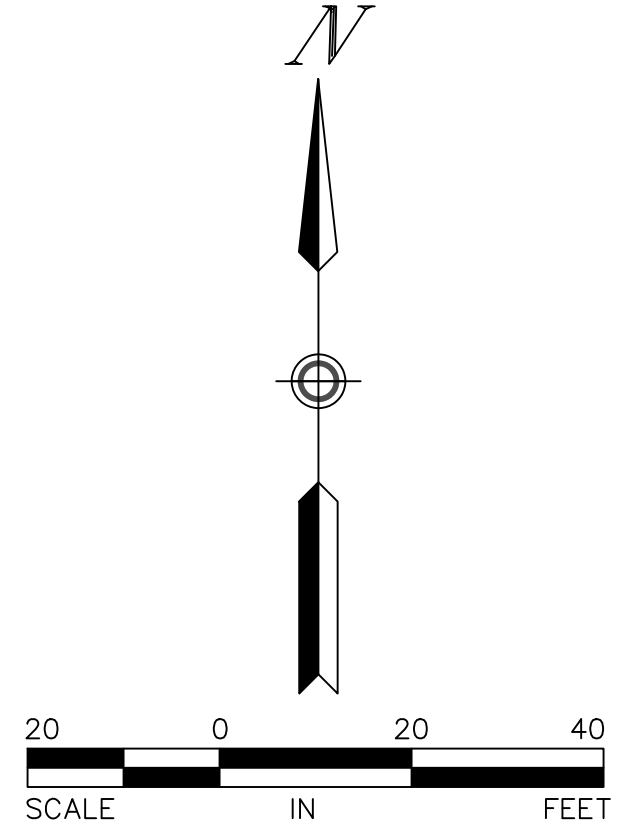



**STAFF REPORT NO. 62**  
**CITY COUNCIL MEETING**  
**3/27/2018**

REPORT PREPARED BY: Jennifer J. Anderson, Support Services Manager

DEPARTMENT DIRECTOR REVIEW: Jay Henthorne, Director of Public Safety/Chief of Police  
3/14/2018

OTHER DEPARTMENT REVIEW: N/A

CITY MANAGER REVIEW: Steven L. Devich, City Manager  
3/19/2018

**ITEM FOR COUNCIL CONSIDERATION:**

**Consideration of the approval of a resolution endorsing smoke-free multi-unit housing within the city of Richfield.**

**EXECUTIVE SUMMARY:**

The Richfield Advisory Board of Health (RABH) has a long history of tobacco policy and prevention work with partners like Minnesotans for a Smoke-Free Generation, Association for Non-Smokers Minnesota, and Clearway Minnesota. In Richfield, tobacco efforts have included recognition of successful retail sales compliance, the inclusion of electronic cigarettes in the City tobacco policy, and stricter cigar sales.

As affordable housing options increase in the city, this provides an opportune time for the City of Richfield to endorse a smoke-free multi-unit housing resolution that seeks to ensure the health, wellness, and safe living conditions for all Richfield residents.

**RECOMMENDED ACTION:**

**By motion: Adopt a resolution endorsing smoke-free multi-unit housing within the city of Richfield.**

**BASIS OF RECOMMENDATION:**

**A. HISTORICAL CONTEXT**

- The smoke-free housing movement has gained significant traction over the past decade from about 50 apartments statewide in 2007 to nearly 4,000 apartments throughout Minnesota today. Unfortunately, smoke-free policy coverage at affordable housing developments and common interest communities lags significantly behind their market rate and luxury rental counterparts, contributing to health inequities for low-income communities, seniors, and people of color.
- Community advocates, local public health, and the Richfield Advisory Board of Health believe that all Richfield residents, regardless of income, deserve a healthy, clean, and safe home environment.
- Currently, free resources and technical assistance are available to Richfield property owners and managers interested in adopting, expanding, or maintaining a smoke-free policy. Additionally free resources are available to support residents who are interested in quitting smoking.

**B. POLICIES (resolutions, ordinances, regulations, statutes, etc):**

- A resolution adopted by the City of Richfield will:

- Address and emphasize the importance and benefits of promoting smoke-free homes in our community;
- Generate public attention to this issue; and
- Create awareness of free resources available to support property owners, managers, and residents.

**C. CRITICAL TIMING ISSUES:**

- N/A

**D. FINANCIAL IMPACT:**

- There is no financial impact with the adoption of this resolution

**E. LEGAL CONSIDERATION:**

- N/A

**ALTERNATIVE RECOMMENDATION(S):**

- The Council may choose to not adopt the resolution.

**PRINCIPAL PARTIES EXPECTED AT MEETING:**

N/A

**ATTACHMENTS:**

Description	Type
▢ Resolution	Resolution Letter

**RESOLUTION NO.**

**RESOLUTION ENDORSING SMOKE-FREE MULTI-UNIT  
HOUSING WITHIN THE CITY OF RICHFIELD**

**WHEREAS**, the City of Richfield has the responsibility to ensure the health, wellness, and safe living conditions of its residents; and

**WHEREAS**, tobacco smoke is a pollutant containing more than 7,000 chemical compounds, of which hundreds are toxic and at least 70 are known to cause cancer; and

**WHEREAS**, according to the US Surgeon General, separating smokers from nonsmokers, cleaning the air, and ventilating buildings cannot completely eliminate exposure to secondhand smoke; and

**WHEREAS**, smoke-free multi-unit housing policies are beneficial for both residents and property owners; and

**WHEREAS**, studies have shown secondhand smoke does transfer from one unit to another in multi-unit housing unit, infringing on the health of individuals living in these properties; and

**WHEREAS**, restrictions on indoor smoking motivates smokers to quit and help former smokers remain smoke free, and

**WHEREAS**, the City of Richfield supports smoke-free multi-unit housing policies per a resolution.

**NOW, THEREFORE, BE IT RESOLVED**, by the City Council of the City of Richfield, Minnesota, as follows:

1. The foregoing recitals contained in the preamble to this Resolution are incorporated by reference herein.
2. The City of Richfield recognizes the health risks of secondhand smoke in multi-unit housing and the necessity of smoke-free housing.
3. The City of Richfield supports property owners and managers who create entirely smoke-free buildings within a multi-unit housing complex.
4. The City of Richfield recognizes that it is empowered to encourage property owners and managers and all Richfield residents to promote healthy, clean, and safe living through the adoption of a smoke-free policy.

Adopted by the City Council of the City of Richfield, Minnesota this 27th day of March, 2018.

---

Pat Elliott, Mayor

ATTEST:

---

Elizabeth VanHoose, City Clerk



**STAFF REPORT NO. 63**  
**CITY COUNCIL MEETING**  
**3/27/2018**

REPORT PREPARED BY: Jared Voto, Executive Aide/Analyst

DEPARTMENT DIRECTOR REVIEW: Steven L. Devich, City Manager  
3/19/2018

OTHER DEPARTMENT REVIEW: N/A

CITY MANAGER REVIEW: Steven L. Devich, City Manager  
3/19/2018

**ITEM FOR COUNCIL CONSIDERATION:**

**Consideration of the designation of a Mayor Pro Tempore for 2018.**

**EXECUTIVE SUMMARY:**

The City Charter states it is necessary to designate a City Council Member to serve as the Mayor Pro Tempore for those times when the Mayor is absent from the City. This item is typically approved at the first meeting in January, but was inadvertently excluded from the agenda.

City Council Member Michael Howard served a Mayor Pro Tempore in 2017.

**RECOMMENDED ACTION:**

**By motion: Approve the City Council designation of a Mayor Pro Tempore for 2018.**

**BASIS OF RECOMMENDATION:**

**A. HISTORICAL CONTEXT**

- This information is contained in the Executive Summary.

**B. POLICIES (resolutions, ordinances, regulations, statutes, etc):**

- The City Council typically considers the designation of a Mayor Pro Tempore at the first meeting in January of each year.
- Section 2.06. The Mayor. Subdivision 1, of the City Charter states: "The Mayor shall be the presiding officer of the Council, except that the Council shall choose from its members a president pro temp who shall hold office at the pleasure of the Council and shall serve as president in the Mayor's absence and as Mayor in case of the Mayor's disability or absence from the City."

**C. CRITICAL TIMING ISSUES:**

- It is necessary to designate a Mayor Pro Tempore to ensure continuation of City operations during an absence of the Mayor.

**D. FINANCIAL IMPACT:**

- This designation is at no additional cost to the City.

**E. LEGAL CONSIDERATION:**

- None

**ALTERNATIVE RECOMMENDATION(S):**

- The City Council may defer the designation to a future City Council meeting.

**PRINCIPAL PARTIES EXPECTED AT MEETING:**

N/A