

URBAN ENTERPRISE ZONE DESIGN GUIDELINES

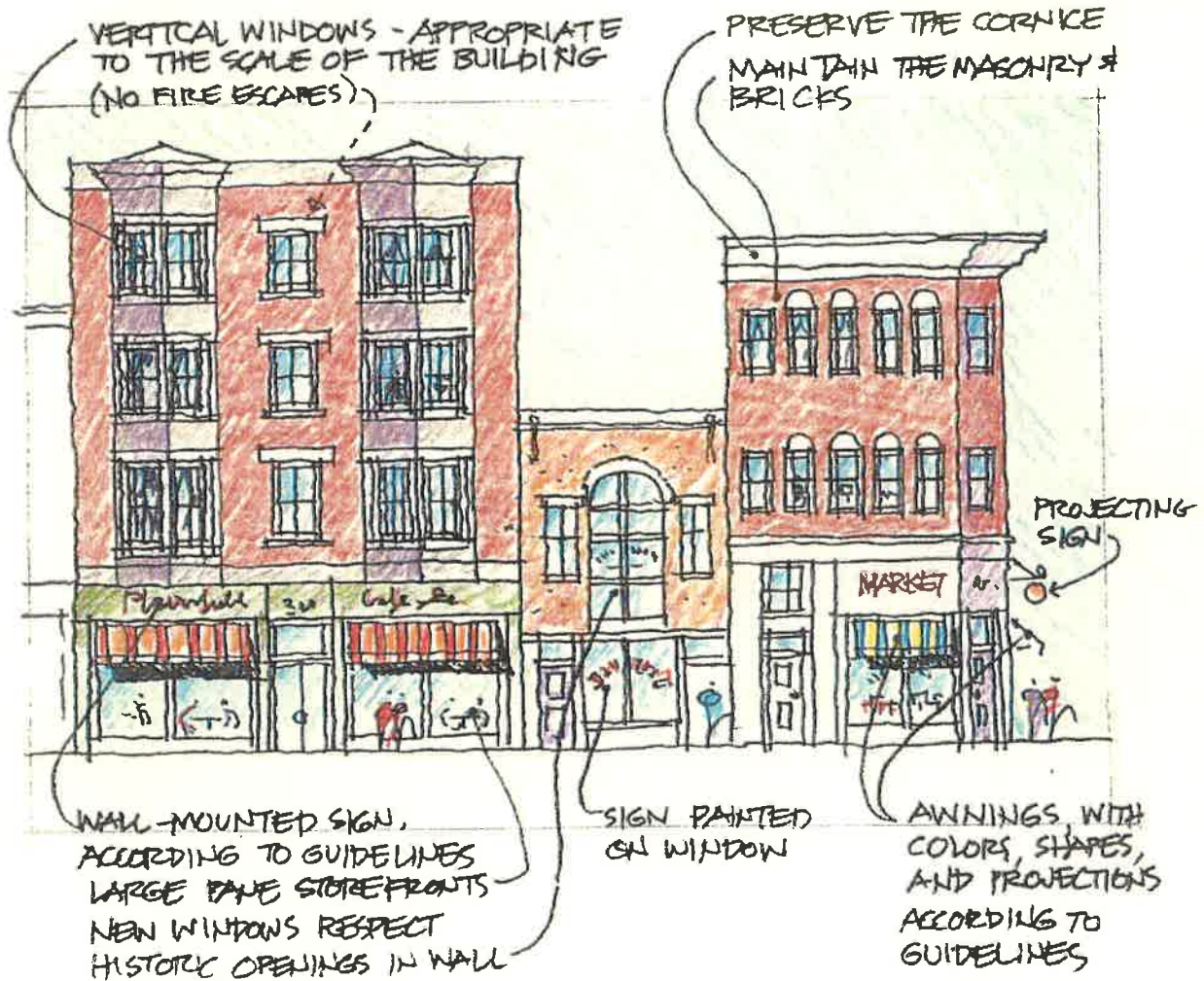

CITY OF PLAINFIELD

UNION COUNTY
NEW JERSEY

URBAN ENTERPRISE ZONE DESIGN GUIDELINES

A project of the Plainfield Office of Economic Development Office, Urban Enterprise Zone Program in conjunction with the City of Plainfield Division of Planning and Community Development.

Albert T. McWilliams, Mayor

Thomas Morrison, City Administrator

Patricia Ballard Fox, Deputy City Administrator – Economic Development

Todd Poole, Plainfield Office of Economic Development

William Nierstedt, Director, Division of Planning and Community Development

PLAINFIELD CITY COUNCIL

Harold W. Mitchell, Council President

Elizabeth Urquhart

Joseph Scott, Sr.

Joseph H. Montgomery

Robert Ferraro

Malcolm R. Dunn

Adrian Mapp

PLAINFIELD PLANNING BOARD

Kenneth Robertson, Chairman

Marquis Jones, Vice-Chairman

Albert T. McWilliams, Mayor

Joseph H. Montgomery, City Councilman

Jacques Howard

Gordon Fuller

Barbara James

William Michelson

Lewis Hurd

Ron Scott Bey

Plainfield Office of Economic Development

Urban Enterprise Zone Program

515 Watchung Avenue

Plainfield, New Jersey 07060

Phone: 908-753-3602

Fax: 908-226-2567

JUNE 2000

TABLE OF CONTENTS

- 1.0 INTRODUCTION.....1**

- 2.0 GUIDELINES AND PERFORMANCE STANDARDS.....3**
 - 2.1 Architectural Design Elements..... 3**
 - 2.1.1 Massing 3
 - 2.1.2 Horizontal Courses 4
 - 2.1.3 Continuity of Treatment..... 4
 - 2.1.4 Signage 4
 - 2.1.5 Scale 5
 - 2.1.6 Roof..... 5
 - 2.1.7 Windows 8
 - 2.1.8 Entrances 8
 - 2.1.9 Security Grilles / Roll-up Doors 8
 - 2.1.10 Physical plant..... 9
 - 2.1.11 Materials, colors and details..... 9
 - 2.1.12 Shutters 9
 - 2.1.13 Multiple uses..... 11

 - 2.2 Awnings and Canopies 11**
 - 2.2.1 Design Standards 11

 - 2.3 Building Orientation and Location..... 12**
 - 2.3.1 Orientation 12
 - 2.3.2 Corner buildings..... 12
 - 2.3.3 Multiple-building developments..... 12

 - 2.4 Sidewalks and Walkways 12**
 - 2.4.1 Lot access and circulation..... 13
 - 2.4.2 Construction and repair specifications..... 13
 - 2.4.3 Materials 13
 - 2.4.4 Public sidewalks 13
 - 2.4.5 Private walkways 13
 - 2.4.6 Illumination 13

 - 2.5 Lighting..... 14**
 - 2.5.1 General design standards 14
 - 2.5.2 Illumination level regulations 14
 - 2.5.3 Building-attached fixtures..... 14

 - 2.6 Landscaping and Street Trees 14**
 - 2.6.1 Landscaping 14
 - 2.6.2 Other site design elements 15
 - 2.6.3 Plant species 15
 - 2.6.4 Planting sizes..... 15
 - 2.6.5 Planting specifications 15
 - 2.6.6 Replacement of dead plantings..... 15

3.1.21 Signs prohibited within the City of Plainfield..... 31

3.2 Fences and Walls 32

3.2.1 Front Yards..... 32

3.2.2 Side and Rear Yards..... 32

3.2.3 Finished Exterior Side..... 32

3.2.4 Materials 33

3.2.5 Drainage 33

3.2.6 Obstruction 33

3.2.7 Retaining Walls..... 33

3.2.8 Exceptions 33

3.3 Shade Trees 34

3.3.1 Location and spacing 34

3.3.2 Corner lots and driveways..... 34

3.4 Parking, Driveways and Loading 34

3.4.1 Driveway location..... 34

3.4.2 Building orientation 34

3.4.3 Building setbacks..... 34

3.4.4 Parking lot location 34

3.4.5 Barrier-free access..... 34

3.4.6 Parking location 34

3.4.7 Loading space location 35

3.4.8 Parking garage/area location 35

3.4.9 Front yard parking prohibited 35

3.5 Parking Lot Landscaping..... 35

3.5.1 Parking lots with ten (10) spaces or less..... 36

3.5.2 Parking lots with eleven (11) spaces or more..... 36

3.6 Parking Space Quantity 37

3.7 Buffering and Screening..... 38

3.7.1 Residential uses 38

3.7.2 Driveways and parking lots 38

3.7.3 Loading areas..... 39

3.7.4 Loading space requirements..... 39

3.7.5 HVAC equipment and utility service boxes..... 39

3.8 Outdoor Displays of Retail Merchandise..... 40

3.8.1 Daily Outdoor Retail Sales 40

3.8.2 41

3.8.2 Seasonal Outdoor Retail Sales 41

3.9 Refuse and Recycling Areas 41

3.9.1 Location/placement..... 41

3.9.2 Buffering and screening 41

3.9.3 Access..... 42

3.9.4 Capacity..... 42

3.9.5 Interior facilities..... 42

1.0 INTRODUCTION

An attractive, well-maintained property contributes positively to the visual impression of an overall neighborhood and plays a crucial part in attracting and maintaining businesses. The purpose of this publication is to serve as a guide to local property and business owners interested in the redevelopment and/or rehabilitation of properties designated in the Urban Enterprise Zone (UEZ). The UEZ Sign and Façade Grant Program provides financial assistance to qualified parties seeking to improve the aesthetic conditions of their UEZ properties. Reinvestment and redevelopment of individual properties will contribute to the UEZ community as a whole. The financial incentive provided by the UEZ Program encourages site specific construction, redevelopment and rehabilitation projects.

The visual identity of the UEZ, as defined by a physical design vocabulary, is critically important to creating a sense of "place." The vocabulary of physical design can be categorized into the components or elements of design. Notable physical design components to be addressed in a plan should include, but not be limited to, the following:

- street graphics/signage
- scale, as defined by the height of the building in relation to its components
- massing, as defined by the shape, dimension and form of a building
- proportion of width to height
- rhythm of solids to voids, as defined by windows, doors and recesses along a wall
- roof form

- horizontal courses
- entrance treatments
- street orientation
- building setbacks
- awnings & canopies
- architectural style, materials & colors
- yard areas
- lighting fixtures and lampposts
- trees & supplemental landscaping
- fences & walls
- trash enclosures
- outdoor retail displays
- relationship to surroundings
- benches
- security measures

Buildings should be made compatible with neighboring areas through the careful application of architectural design elements. An individual development plan shall not be considered on its own, but with sufficient regard to the existing streetscape neighborhood and district in which it is located and to the City in general. Appropriate consideration and respect should be given to abutting and nearby properties.

The physical, visual and spatial characteristics of a streetscape, neighborhood, district and the City shall be established and reinforced through the consistent use of compatible design elements. If a site is located in an area where existing design elements are weak or nonexistent, the planned improvements should include design elements that relate to the community generally. In the case of an addition to or renovation of an existing building, the proposed improvements should relate to and reinforce design elements of the existing building.

2.0 GUIDELINES AND PERFORMANCE STANDARDS

2.1 Architectural Design Elements

The following guidelines should be used to prepare and review the architectural design of new buildings and structures. Where improvements involve an existing building and/or a site upon which it is located, the existing building shall be repaired, renovated and restored to comply with this section.

2.1.1 Massing

A building having a total measurement greater than one hundred and fifty (150) feet in length along any wall, roof or footprint plane is undesirable. Building wall offsets, including both projections and recesses, should be provided along any building wall measuring fifty (50)

feet or greater in length. This requirement is to provide architectural interest and variety to the massing of a building and relieve the negative visual effect of a single, lengthy wall. The recommended measurement of wall offsets is a minimum of ten percent (10%) of the building wall length. The spacing between wall offsets should be no greater than forty (40) feet. The minimum projection or depth of any individual wall offset shall not be less than two (2) feet.

Roofline and wall offsets create a desirable façade. A roofline offset should be provided along any roof measuring longer than seventy-five (75) feet in length. This is in order to provide architectural interest and variety to the massing of a building and relieve the negative visual effect of a single, long roof.

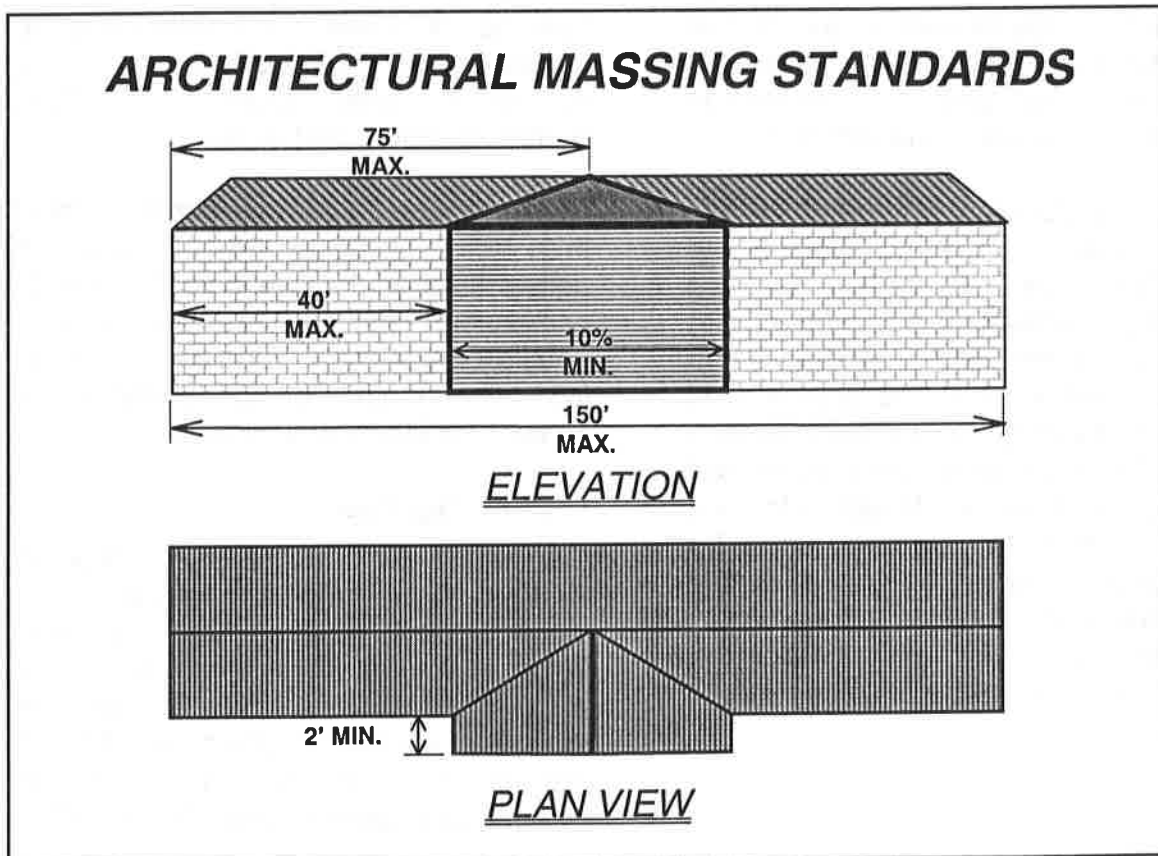

building or a site. If a sign is to be internally illuminated, a dark-colored face with light-colored lettering is always preferred since it produces less glare than a light-colored face with dark-colored lettering.

All signage affixed to a building shall conform to the regulations set forth in Article XI of the City's Land Use Ordinance (hereinafter referred to as "Ordinance"). The Ordinance regulates the size, height, width, placement, materials and the method of illumination for all signs in the City. All signage requires a zoning permit. Any deviation from Ordinance sign regulations necessitates variance relief granted by either the Zoning Board of Adjustment or the Planning Board. The majority of the sign regulations are included within the subsequent section, entitled Zoning Regulations.

2.1.5 Scale

The height of a building should not significantly deviate from the building heights at adjacent lots or along the street frontage within the block where it is located.

2.1.6 Roof

The type, shape, pitch, texture and color of a roof shall be considered as an integral part of the design of a building and shall be architecturally compatible with the style, materials, colors and details of such building. The minimum permitted roof pitch shall be eight on twelve (8/12) and all gables on a building shall be of the same pitch. A flat roof may be permitted on a building of a minimum of two (2) stories in height, provided that all visibly exposed walls shall have an articulated cornice that projects out horizontally from the vertical building wall plane. A mansard roof may be permitted, but only if such is located on the third story of a building, completely and integrally enclosing such story. Flat or mansard roofs are discouraged on all one (1) story buildings.

Architectural embellishments that add visual interest to roofs, such as dormers, belvederes, masonry chimneys, cupolas, clock towers and such similar elements shall be permitted, provided these elements are architecturally compatible with the style, materials, colors and details of the building.

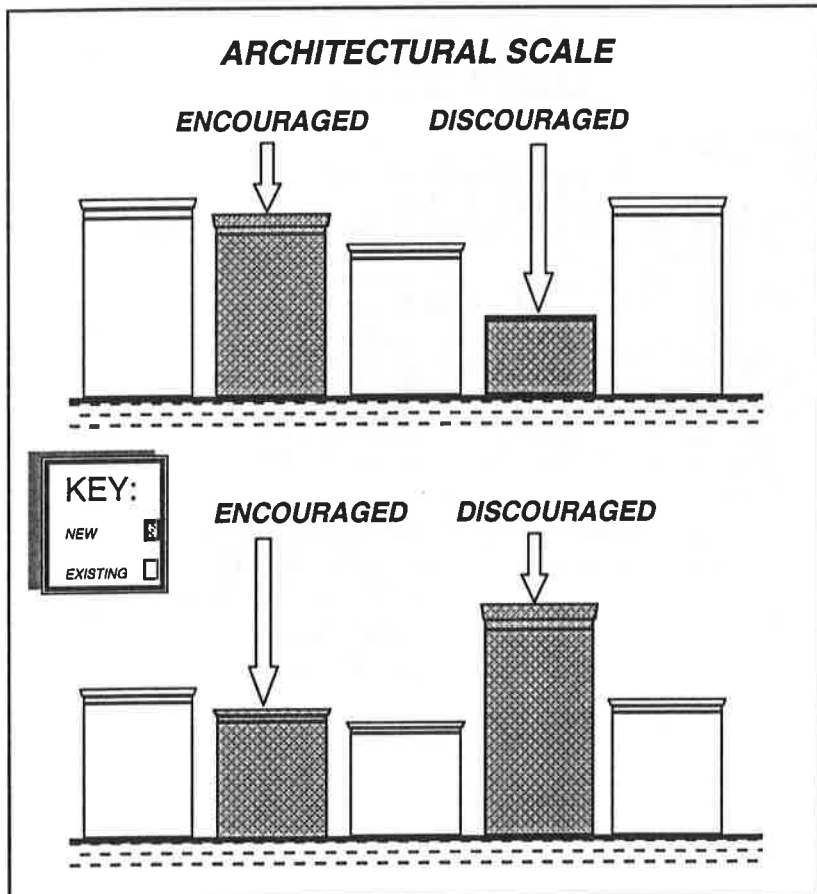

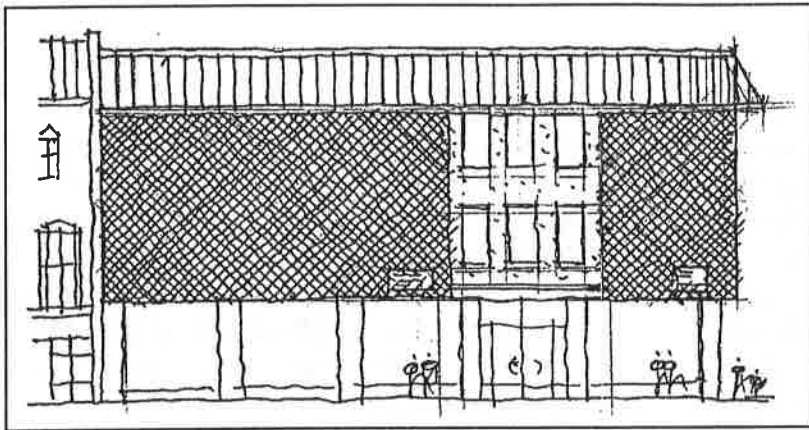

Front Street / Park Avenue (First Union Building)

Existing Condition

Possible Improvement

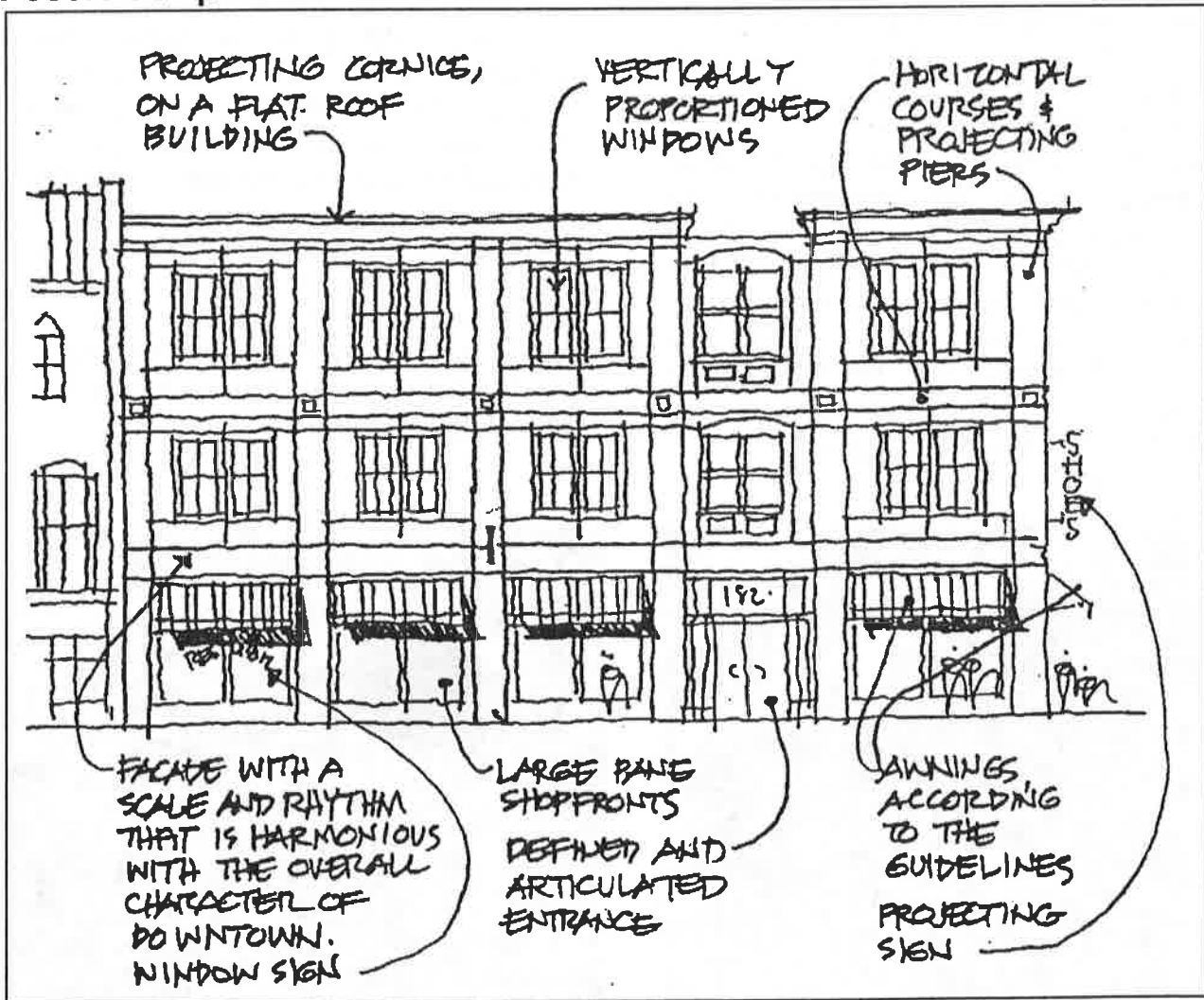

Straight lattice design security grille

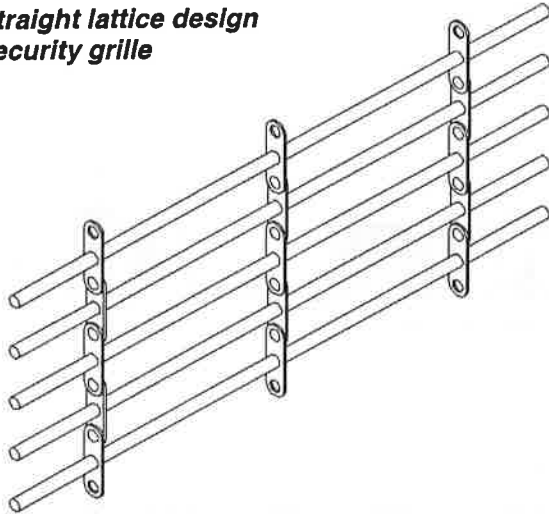

Brick pattern lattice design security grille

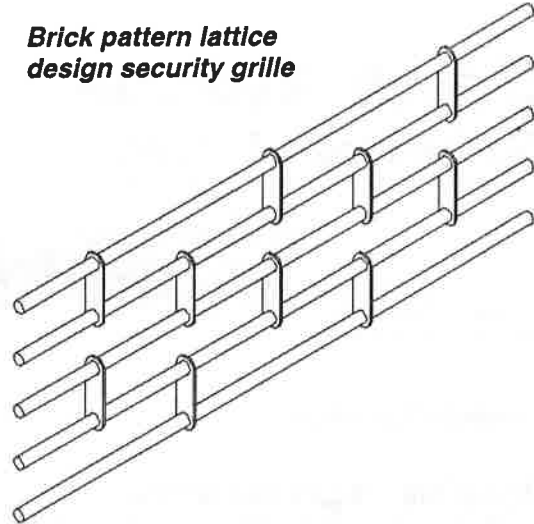

If a security grille is absolutely necessary, it should be a least 60% non-solid. The standard curtain pattern is a straight lattice design with horizontal rods at 2 inches on center and vertical links at 9 inches on center. For added visual interest, a staggered “brick pattern” with 4-½ inch horizontal spacing may be preferable.

The security grille coil, whether side- or overhead-mounted, should never be attached to the exterior of the building. When the security grille is in the closed position it should be located on the interior side of the windows so as not to degrade the architectural design features along the streetscape.

Where headroom is limited a folding or accordion grille may be installed in lieu of the typical roll-up type. Any sliding type security grille must also be non-solid and situated on the interior side of the windows.

An emergency egress feature should always be incorporated into the design and installation of any security grille.

2.1.10 Physical plant

All air-conditioning units, HVAC systems, exhaust pipes or stacks and elevator housing shall be shielded from view. Such shielding shall be accomplished by utilizing the walls or roof of the building or a penthouse-type screening device that shall be designed to be architecturally compatible with the style, materials, colors and details of such building.

2.1.11 Materials, colors and details

All materials, colors and details used on the exterior of a building shall be architecturally compatible with the style of such building, as well as with each other. A building designed of an architectural style that normally includes certain integral materials, colors and/or details shall have such incorporated into the design of such building.

2.1.12 Shutters

A building designed of an architectural style that normally includes shutters shall provide such on all windows on the front façade. If such building is located on a corner lot, shutters shall be provided on all windows of all facades fronting on a street.

2.1.13 Multiple uses

A building with multiple storefronts or other multiple uses, no matter whether such uses are the same type of use or located on the same floor level, shall be unified through the use of architecturally compatible styles, materials, colors, details, awnings, signage, lighting fixtures and other design elements for all such storefronts or uses.

2.2 Awnings and Canopies

An awning is a structure made of cloth, canvas or vinyl, with a frame attached to a building or other structure which is so erected as to permit it to be raised to a position against the building or structure when not in use. A canopy is a structure, in a fixed position, made of cloth, plastic, metal or other substance and provides a permanent roof-like shelter over a public or quasi- public

right- of- way.

The ground level of a building in a business district may have awnings or canopies, where appropriate, to complement the architectural style of a building. Awnings may also be used on the upper levels of a building, where appropriate. The design of awnings and canopies shall be architecturally compatible with the style, materials, colors and details of such building. Internally illuminated or backlighted awnings and canopies are not appropriate. The following standards for ground-level awnings and canopies should be adhered to.

2.2.1 Design Standards

- a. The maximum height from ground-level to uppermost portion of such awning or canopy shall not exceed the height of the sill or bottom of any

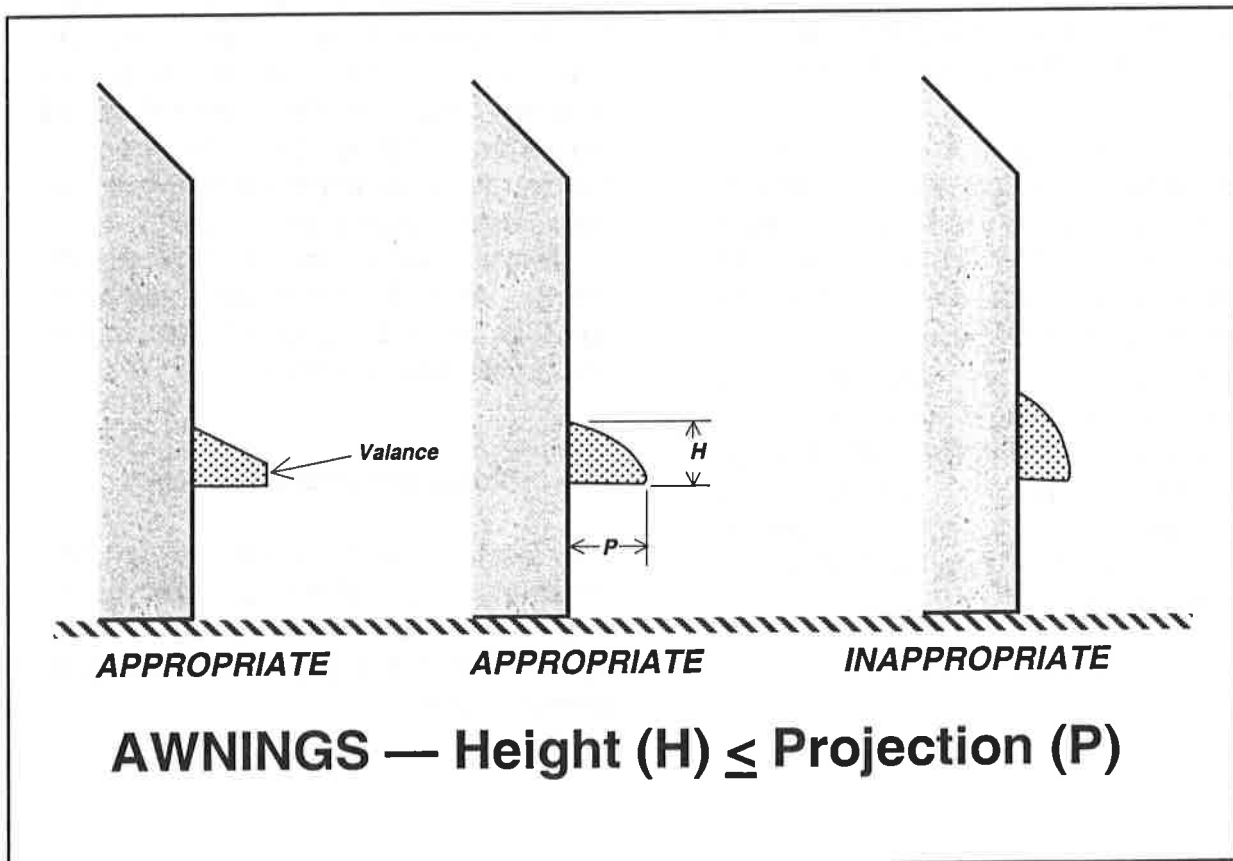

2.4.1 Lot access and circulation

Such access shall be designed for the safety, control, efficient movement, convenience and encouragement of pedestrian traffic into and out of the site and to promote pedestrian circulation within the UEZ. A walkway system shall promote pedestrian activity both on site and throughout the community through its integration with the City sidewalk system. Walkways shall be separate from motor vehicle circulation to the greatest extent possible and shall provide a pleasant route for users to promote enjoyment of the site and encourage incidental social interaction among pedestrians.

2.4.2 Construction and repair specifications

All sidewalks and walkways shall meet the construction or material specifications as set forth in applicable city ordinances or as approved by the City Engineer. This shall also apply to recommendations by the City Engineer regarding the maintenance, repair or upgrading of existing sidewalks located in that portion of the public right-of-way that directly abuts the tract to be renovated or developed.

2.4.3 Materials

In no instance shall a sidewalk located in a public right-of-way be constructed of asphalt. The applicant must demonstrate that the paving materials will be architecturally compatible with the style, materials, colors and details of buildings and other structures on the site and adjacent properties and will create a more attractive development generally. Applicants shall coordinate with the Plainfield Downtown Streetscape Plans.

Dry-laid brick pavers are popular and can be accented by a border edging of dry-laid cobble pavers. Whenever existing concrete is being replaced, an effort to match the texture and color of adjacent walkways should be made.

2.4.4 Public sidewalks

Sidewalks shall be provided in the right-of-way along all public and private streets. The location and width of sidewalks shall be consistent with the location and width of existing sidewalks adjacent to or near the site to be developed, but in no case shall be less than four (4) feet in width.

2.4.5 Private walkways

Walkways shall be located on a site to facilitate pedestrian access between the public sidewalk, buildings, parking lots and other facilities and to provide for pedestrian circulation generally within a site. Where walkways abut the ends of parking spaces and wheel stops are not provided, the minimum width of such walkways shall be a minimum of five (5) feet in order to provide for the front ends of vehicles to overhang onto such walkways with appropriate space remaining for the passage of pedestrians. In no case shall a private walkway be less than four (4) feet in width.

2.4.6 Illumination

As required by Article IX and XII of the Ordinance, minimum walkway illumination levels must be provided. All walkway lighting fixtures shall be designed to be architecturally compatible with the style, materials, colors and details of other lighting fixtures used on the site.

- h. maintenance of a desirable ecological balance on a developed site.

2.6.2 Other site design elements

A development plan shall incorporate landscaping with other functional and ornamental site design elements, where appropriate, such as the following:

- a. courtyards, plazas, alleys and similar public and semi-public open spaces;
- b. active recreation areas and facilities;
- c. ground paving materials;
- d. paths and walkways;
- e. berms and other earth forms;
- f. ponds, fountains and other water features;
- g. trellises, pergolas, gazebos and other accessory structures;
- h. fences, walls and other screens;
- i. street or site furniture;
- j. art and sculpture;
- k. vehicular parking areas

2.6.3 Plant species

The selection of plant species to be used shall be appropriate in terms of function and size and shall be hardy for the climatic zone in which the City is located. Consideration shall be given to soil conditions, availability of water, exposure to sunlight, curbing, impervious surfaces, overhead wires and other existing conditions.

2.6.4 Planting sizes

Deciduous trees shall have a minimum caliper of three (3) inches at time of planting. Evergreen trees shall be a

minimum of six (6) feet in height at time of planting. Low-growing evergreen shrubs shall be a minimum of two and one-half (2½) feet in height at time of planting. Size of other plantings shall depend on setting and type of plant material.

2.6.5 Planting specifications

Only nursery-grown plant material shall be utilized. All trees, shrubs and ground cover shall be planted according to accepted horticultural standards. All grass shall be planted in accordance with the New Jersey State Soil Conservation Committee's Standards for Soil Erosion and Sedimentation Control in New Jersey, current edition. Trees and other vegetation that have been removed may be reduced to chips and used as mulch in landscaped areas. Maintenance Plantings shall be watered regularly and in a manner appropriate for the specific plant material through the first growing season. All landscaped areas shall be well maintained and kept free of all debris, rubbish, weeds, tall grass, other overgrown conditions and the storage of any equipment or materials.

2.6.6 Replacement of dead plantings

The developer shall be required to replace dead or dying plant material for a period of two years from the date of issuance of a final certificate of occupancy and shall post a maintenance guaranty for such pursuant to Article XV of this Ordinance.

If plant material is dead or dying during a planting season, it shall be replaced that same season. If plant material is dead or dying during a non-planting season, it shall be replaced as soon as

interfere with below-grade utilities, roadways, sidewalks, overhead wires, or streetlights. Shade trees shall be permitted within a sight triangle. All branches are to be trimmed away to a height of at least eight (8) feet above the curb level as required in Article IX of the Ordinance.

2.6.15 Street tree specifications

Street trees shall be planted at a minimum size of three and one-half (3 1/2) inches in caliper minimum to twelve (12) feet in height and shall be planted according to accepted horticultural standards. All street trees to be planted shall be nursery grown, of substantially

uniform size and shape and shall have straight trunks. Ornamental trees need not have straight trunks, but should conform in all other respects with the provisions for trees and tree plantings outlined herein.

2.6.16 Street tree grate

Where street trees are planted within a paved sidewalk area they should be provided with a grate. The grate must be have an opening with a minimum diameter of 18 inches. A square-shaped tree grate with radial spokes is recommended (shown to the left) to permit a larger center opening as the diameter of tree trunk expands with age. A non-abrasive cutting wheel can remove the radial spokes of the grate. All tree grates shall be constructed of cast iron.

STREET TREE GRATE

180° SQUARE

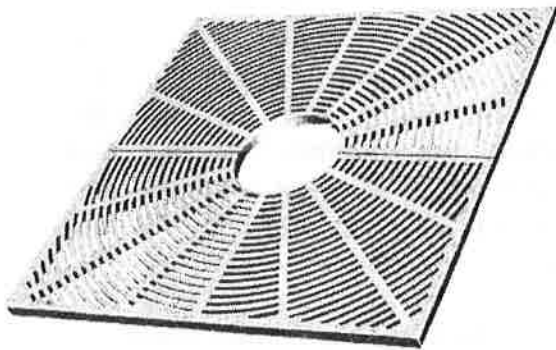

Note 3/8" slot openings for special pedestrian requirements. Grate is notched in underside ribs for ease of expanding tree opening to 18" and 24". Available with cast iron angle frame, if required.

Weight per set -- 290 pounds.

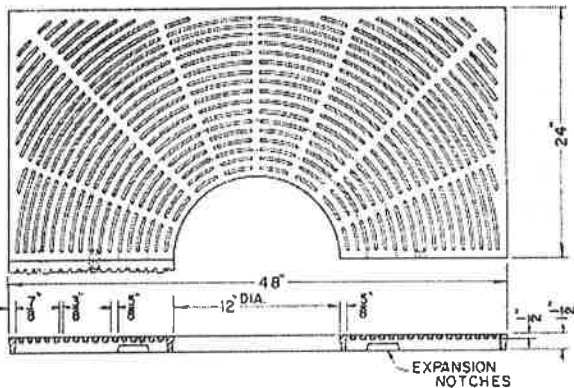

HALF PLAN AND SECTION

2.6.17 Recommended street trees

This list is not all inclusive. Other species may be planted if approval is obtained from the City Planning Division.

- Hackberry
- Autumn Purple Ash
- Ginkgo
- London Planetree
- Sycamore
- Scarlet Oak
- Bur Oak
- Willow Oak
- Red Oak
- Scholartree
- Crimean Linden
- Silver Linden
- Chinese Elm
- Japanese Zelkova

2.8.6 Layout

All parking lots and loading areas shall be designed for the safety, control, efficient movement and convenience of motor vehicle circulation within a site. Traffic circulation shall be designed to minimize the use of aisles serving parking areas as access drives. Parking areas with more than twenty-five (25) spaces shall have entrances and exits separated by a landscaped traffic island, where possible.

2.8.7 Aisle dimensions

Where no parking is provided, interior driveways shall be eleven (11) feet wide for one-way traffic and twenty-two (22) feet wide for two-way traffic. Where parking is provided, parking lot aisles shall measure as follows.

ANGLE OF PARKING STALL (IN DEGREES)	WIDTH OF ONE-WAY TRAFFIC AISLE	WIDTH OF TWO-WAY TRAFFIC AISLE
0 (parallel)	11 feet	22 feet
30	12 feet	not permitted
45	13 feet	not permitted
60	18 feet	not permitted
90 (perpendicular)	24 feet	24 feet

2.8.8 Shared Parking

Shared access and parking facilities shall be permitted and are encouraged in all non-residential zones to minimize the disruption of traffic flow, reduce access points to adjacent roadways and reduce conflicts with pedestrian traffic. Such joint access and parking areas for individual non-residential uses shall be designed to be interconnected via cross-easements with adjacent properties and shall utilize common entrances and exits. The total number of spaces required for uses involved in such shared arrangements shall not be less than the total sum for each use as

required by the Ordinance's Table of Parking Regulations. Each plan must be submitted to and approved by the appropriate approving authority.

2.8.9 Construction and repair specifications

All parking lots and loading areas shall be constructed or repaired to specifications as approved by the City Engineer.

public purpose sign – A sign designed to promote the public health, safety and welfare, including official government notices, government signs, signs to control and direct traffic on public streets, street identification signs, signs erected by public utility companies to warn of dangerous or hazardous conditions and political signs.

reader board sign – A temporary, portable sign that incorporates changeable lettering and is intended primarily for advertising or announcement purposes.

real estate sign – A sign pertaining to the sale or lease of the premises, or a portion thereof, on which the sign is located.

residential development sign – A sign identifying a residential major subdivision, condominium, apartment or townhouse complex, and is located entirely on the property which it is identifying.

residential nameplate sign – A wall sign permitted for the sole purpose of identifying the inhabitant residing therein, the house name and/or identifying the address of the house.

roof sign – A sign that is mounted on the roof of a building or is wholly dependent upon a building for support, and that projects above the top walk or edge of a building with a flat roof, the eave line of a building with a gambrel, gable or hip roof, or the deck line of a building with a mansard roof.

sidewalk sign – A temporary, moveable, non-illuminated sign located within the public right-of-way that is not permanently affixed to a wall, structure or to the ground.

traffic-control sign – A permitted sign for the purpose of identifying private parking areas and directing the flow of traffic on private property.

TYPES OF PERMITTED SIGNS

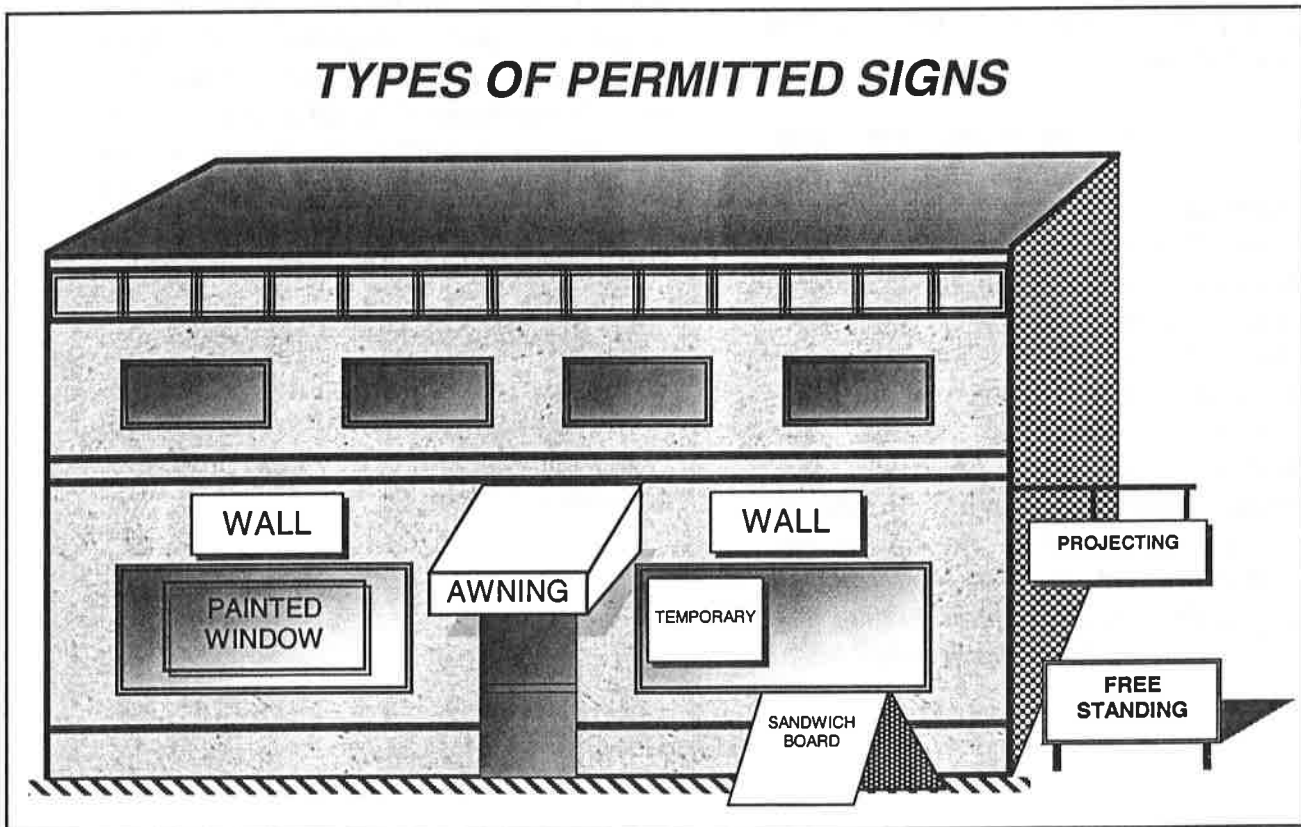

3.1.6 Computation of sign height

Sign height shall be measured between average grade immediately below the sign and the highest point of the highest element of the sign. Wall signs shall not project above the top or beyond the ends of the wall surface upon which they are placed, nor shall wall signs be placed on a parapet or similar architectural device such that the sign would project above the elevation of the roof behind such parapet or other device.

3.1.7 Sign illumination

Illuminated signs may be floodlighted, spotlighted or backlighted from the rear with a diffused light source, unless such illumination is specifically prohibited elsewhere in the ordinance. For example awning signs may not be backlighted. All illumination shall be subject to the following.

- a. All lighting sources shall be completely shielded from the view of vehicular traffic.
- b. Such illumination shall not project light above the highest elevation of the front wall of the building for wall-mounted signs or more than five feet above ground level for freestanding signs.
- c. Backlighted signs shall not have a white or light-colored background or signboard.
- d. Where a sign is located on a lot adjacent to a lot used primarily for residential purposes, such shall not be illuminated in a manner that permits any light to shine or cause a nuisance to the adjacent residential use.

- e. No illuminated sign located on a lot adjacent to or across the street from any residential district and visible from such residential district shall be illuminated between the hours of 11:00 p.m. and 7:00 a.m., unless the use to which the sign pertains is open for business during those hours.
- f. No sign shall contain blinking, flashing, flickering, tracer or sequential lighting. All signs shall remain stationary and constant in intensity and color at all times.
- g. All wiring for permanent illuminated signs shall be installed and maintained so that it is not within public view. The running of wiring or conduit along the exterior wall of a building to access a sign is specifically prohibited unless in the judgment of the Construction Official there is no practical way to run the conduit so that it is not within public view.
- h. No illuminated sign shall be of such a color or located in such a manner as to be confused with, or to diminish or detract in any way from, the effectiveness of any traffic signal or similar official safety or warning device.

3.1.8 Sign content

The content or advertising which may be displayed on signs shall be limited to the identification and location of the premises, identification of its owners or occupants and information concerning the activities conducted on the premises or the goods and services offered in connection therewith.

The objective of is to minimize undesirable off-premises effects. No light shall shine into building windows, nor onto streets and driveways so as to interfere with or distract driver vision. To achieve these requirements, the intensity of such light sources, the light shielding and similar characteristics shall be subject to approval. Wall mounted fixtures are only permitted if directed into a site and not positioned towards neighboring properties or public streets.

3.1.14 Signs permitted in all non-residential zoning districts

Awning Signs — Ground floor business uses in non-residential zones may display signs on awnings, provided that the following standards are met:

- The dimensions of the awning shall be in conformance with applicable regulations set forth in Article XII of the ordinance (see **Section 3.2**).
- The sign shall only be located on a portion of the awning that is both parallel to the vertical orientation of the building wall to which it is attached and is parallel to the building line of the building wall to which it is attached. This portion is more commonly known as the "valance."
- The horizontal dimension of the sign shall not exceed fifteen (15) feet, or sixty percent (60%) of the length of the awning occupied by the use, whichever is less.
- The maximum vertical dimension of the sign face shall not exceed
- Awning signs shall only be permitted on first-story awnings.

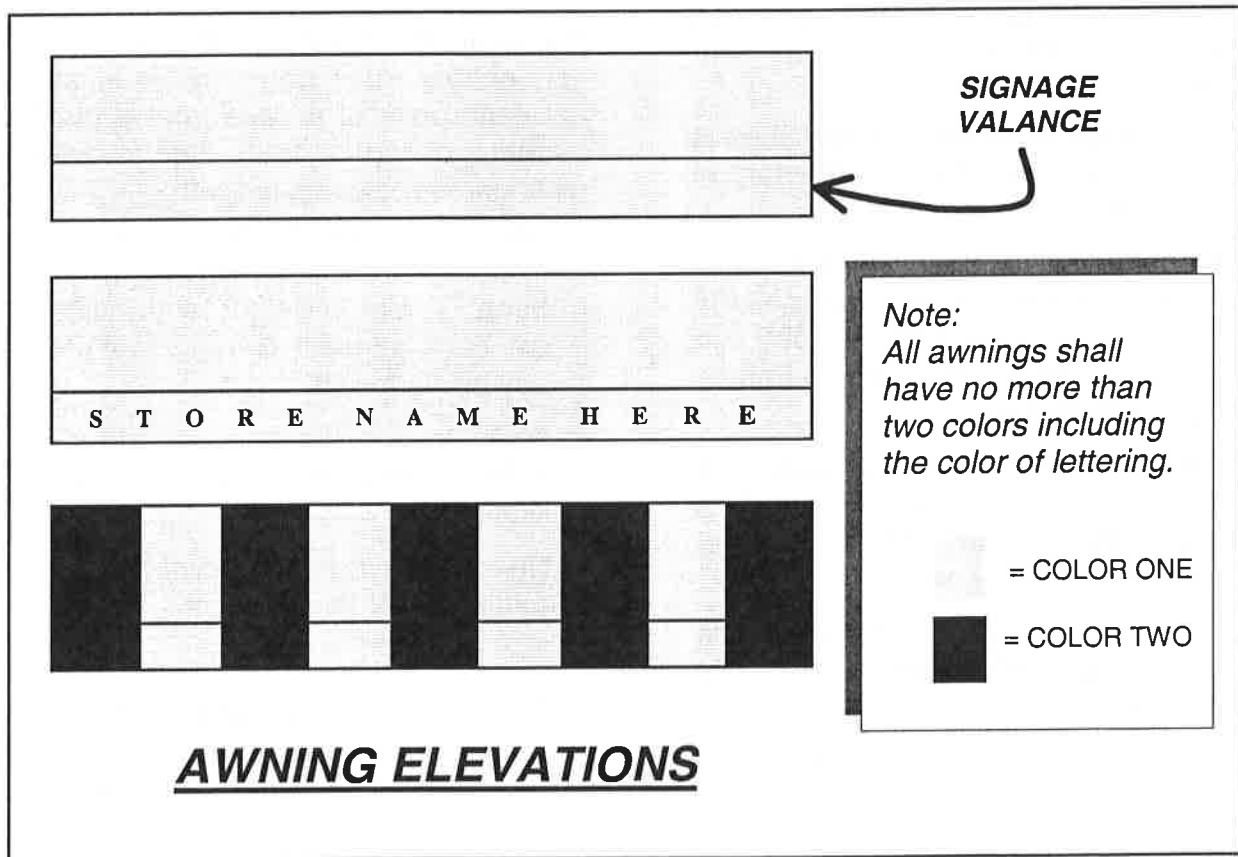

designed to blend harmoniously with other on-site signage.

- Such signs must conform to the Manual of Uniform Traffic Control Devices (MUTCD) standards.

Directional Signs — Directional signs are to be located on-site when deemed necessary to ensure pedestrian and traffic safety. Directional signs must comply with the following standards:

- Directional signs may not exceed two (2) square feet in area, three (3) feet in height, and may not be located within a required setback area.
- Such signs may be indirectly illuminated, and must conform to the Manual of Uniform Traffic Control Devices (MUTCD) standards.

Wall-mounted Directory Sign — For buildings containing more than one (1) non-residential tenant, one (1) wall-mounted directory sign for each ground floor entrance to a building shall be permitted whether such entrance fronts on a street or parking lot. The maximum size of the directory shall not exceed five (5) square feet in area. Such sign may identify all building occupant names and their addresses, however, any individual business shall not occupy greater than one square foot in area of such sign. A wall-mounted directory sign may not be illuminated.

3.1.15 Signs permitted in the Central Business District Zone

Wall Sign — One (1) wall sign is permitted for each ground floor business use maintaining street frontage and is regulated as follows:

- The sign shall be located on the wall at the main public entrance or centered along the street frontage such use occupies.
- The mounting height of the sign shall not exceed the height of the ground floor, or fourteen (14) feet, whichever is less.
- The horizontal dimension of the sign shall not exceed twenty (20) feet, or seventy-five percent (75%) of the width of the building frontage occupied by the use, whichever is less.
- The vertical dimension of the sign shall not exceed two and one-half (2-1/2) feet.
- Maximum permitted sign area is twenty-four (24) square feet.
- The sign may be internally or indirectly illuminated.

Projecting Sign — One (1) projecting sign is permitted for each ground floor business use maintaining street frontage and is regulated as follows:

- The sign shall be attached to the wall along the frontage such use occupies.
- Such sign face and all signage must be oriented in a position that is perpendicular to the wall to which it is attached.

- In a building with multiple business occupants who share a common entrance, no more than two (2) such signs shall be permitted, which may be shared among the applicable businesses entitled to a portable special promotion sign under the provisions of this section.
- Any business use that places or installs such sign, pursuant to this section, shall be required to conform to all other applicable provisions of this article, otherwise, such business shall be prohibited from displaying such sign.
- Such signs shall not be illuminated.

3.1.16 Signs permitted in the General Commercial and Neighborhood Commercial Zones

Wall Sign — One (1) wall sign is permitted for each ground floor business use maintaining street frontage and is regulated as follows:

- The sign shall be located on the wall at the main public entrance or centered along the street frontage such use occupies.
- The mounting height of the sign shall not exceed the height of the ground floor, or twelve (12) feet, whichever is less.
- The horizontal dimension of the sign shall not exceed twenty (20) feet, or seventy-five percent (75%) of the width of the building frontage occupied by the use, whichever is less.
- The vertical dimension of the sign shall not exceed two and one-half (2-1/2) feet.

- Maximum permitted sign area is twenty-four (24) square feet.
- The sign may be internally lit, and may not be indirectly illuminated.

Freestanding Sign — One (1) freestanding sign is permitted only if the depth of the yard in which the sign is located is at least twenty (20) feet. Such freestanding sign shall be regulated as follows:

- No more than one (1) such sign shall be permitted on any lot.
- The sign shall be located in the front yard.
- The sign shall be located at least five (5) feet from any property line.
- The area of the sign shall not exceed sixteen (16) square feet.
- The mounting height of the sign shall not exceed eight (8) feet.
- Neither the horizontal or vertical dimension of the sign shall exceed six (6) feet.
- The maximum height of the sign shall not exceed fourteen (14) feet.
- The sign may be indirectly illuminated, or may be lit by an internal source.

3.1.17 Signs permitted in the Mixed Use Zone

Wall Sign — One (1) wall sign is permitted for each lawfully permitted ground floor non-residential use maintaining street frontage and is regulated as follows:

- The sign shall be located on the wall at the main public entrance or centered along the street frontage such use occupies.

3.1.20 Permitted temporary signs

The following temporary signs require a zoning permit and are subject to the following regulations.

Banners, pennants and bunting may be used for special promotional events, holidays and grand openings. Such banners, pennants and bunting may not be displayed more than two (2) times per calendar year, and may be in place for no more than two (2) months at a time. Banners, pennants and bunting may constitute an aggregate area not to exceed fifteen (15) square feet, must be attached flush to a wall, and may not be illuminated in any fashion.

Project signs may be permitted for new major residential and non-residential site pursuant to final approval from the approving authority. No more than one (1) project sign shall be permitted on any lot identifying builders, contractors, architects, engineers or others associated with the construction of any building situated on any such lot. Such signs shall be set back at least ten (10) feet from all property lines, and shall not exceed twenty (20) square feet in area or twelve (12) feet in height.

Freestanding or wall mounted real-estate signs of up to twenty (20) square feet for non-residential uses may be erected in non-residential zones for a period of ninety (90) days. A window sign of up to twelve (12) square feet may be used for the same purposes. Freestanding signs must be setback from all property lines at least ten (10) feet.

Contractor signs are permitted in all zone districts. Maximum sign area of fifteen (15) square feet; minimum setback of ten (10) feet from all property lines; may not be illuminated; may be permitted for the duration of the exterior improvement activity, and must be removed within two (2) weeks of completion of improvement.

3.1.21 Signs prohibited within the City of Plainfield

The following signs are prohibited within the City of Plainfield, unless otherwise specified within Ordinance.

- signs utilizing inert ionized gas sign lighting, commonly called neon, when the neon tube is visible, including window surrounds and similar inert gas illumination with or without a distinct message;
- signs in the public right-of-way unrelated to the public health, safety and welfare;
- signs which project more than nine (9) inches from a wall surface;
- any sign for advertising purposes that mimics or is substantially similar to a public purpose sign;
- signs with lights or illuminations which flash, move, rotate, scintillate, blink, flicker, vary in intensity, vary in color, or use intermittent electrical pulsation;
- signs within designated sight triangles, and signs which directly obstruct driver's lines-of-sight;
- non-public banners that stretch across a public right-of-way between telephone poles, trees or other structure;
- roof signs;

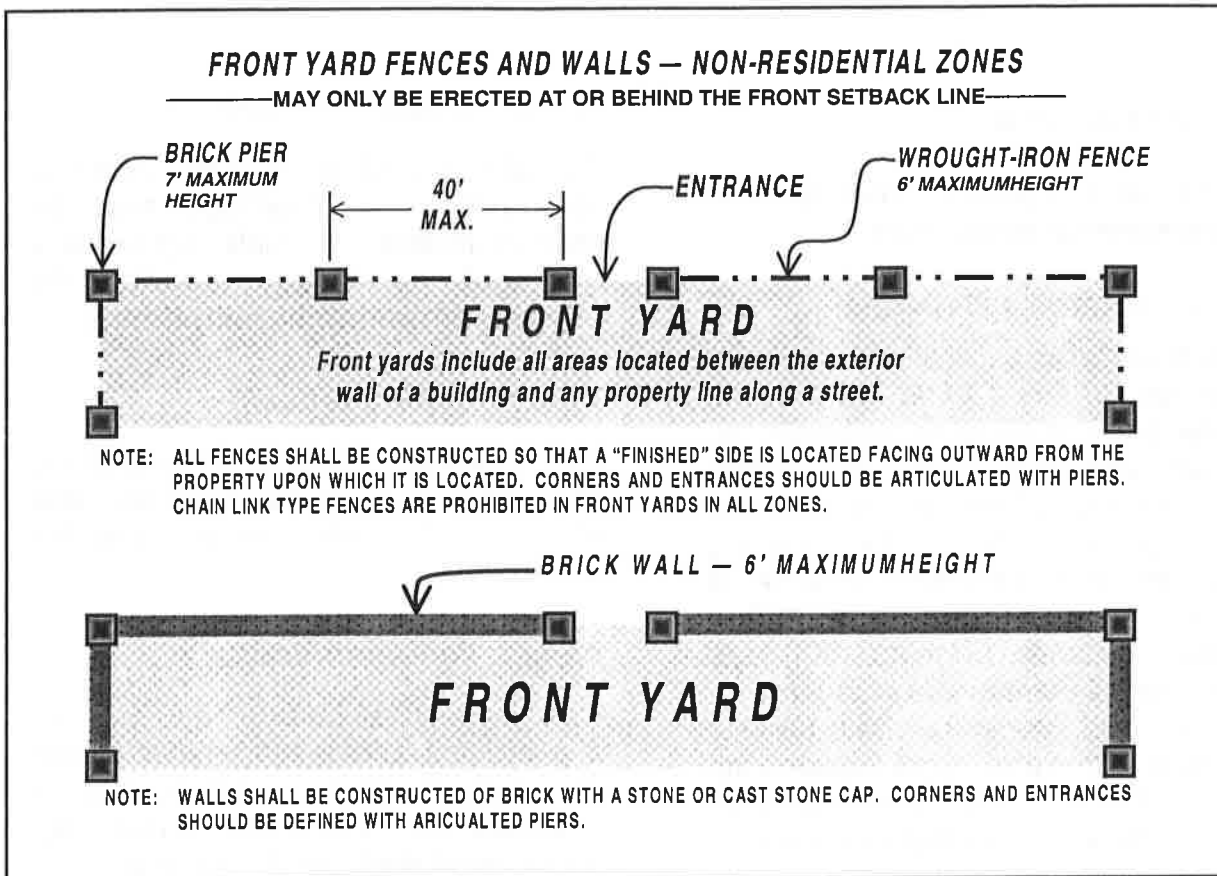

3.2.4 Materials

No fence or wall shall be constructed or installed with barbed wire, metal spikes, or topped with concertina or razor wire, broken bottles or similar materials so as to be dangerous to humans or animals. In addition, chain link fences are specifically prohibited in front yard in all zones.

3.2.5 Drainage

Fences and decorative walls shall be constructed in a manner so as to permit the continued flow of natural drainage and shall not cause surface water to be blocked or dammed to create ponding, either on the property upon which such is located or on any adjacent lot. Those applying for a zoning permit to erect a fence or decorative wall shall consult

with the City Engineer to ensure compliance with this provision.

3.2.6 Obstruction

No fence shall be constructed within any sight triangle as defined in this article, or installed so as to constitute a hazard to traffic or public safety.

3.2.7 Retaining Walls

Any permitted wall proposed to be used as a retaining wall shall be required to be reviewed by the City Engineer prior to the issuance of a zoning permit.

3.2.8 Exceptions

Fences or walls that constitute a permitted buffer area screen approved as part of a site plan application shall be excepted from the above height and location provisions.

3.4.7 Loading space location

All loading areas shall be located on the same lot as the use being served. No loading area shall be located in a front yard. There shall be no loading in a yard abutting, or in a public right-of-way. No loading space shall be located within forty (40) feet of an intersection of any two public right-of-ways. The off-street loading space shall be located on the property so as to permit any vehicle to be parked in the loading space with no portion of the vehicle extending into the public street.

3.4.8 Parking garage/area location

No commercial parking garage or area for twenty-five (25) or more vehicles shall have an entrance or exit for vehicles within 1,000 feet along the same side of a street upon which is located a school, public playground, house of worship, hospital, public library or institution for dependents or children, except where such property is in another block or on another street on

which the zone line does not abut. Such access shall not be closer to the intersections of any two (2) streets than fifty (50) feet. No access drive or driveway shall be located in any residential district to provide access to uses other than those permitted in such residential zone. No driveway shall serve any use other than the permitted use on the lot upon which the driveway is located.

3.4.9 Front yard parking prohibited

In all zone districts and for all uses except single-and two-family dwellings, parking lots or individual spaces shall be prohibited within front yard areas.

3.5 Parking Lot Landscaping

The interior area of all parking lots shall be landscaped to provide visual relief from the undesirable and monotonous appearance of extensive parking areas, and to provide shading that will reduce solar heat gain to both the surface of the parking lot and vehicles parked thereon.

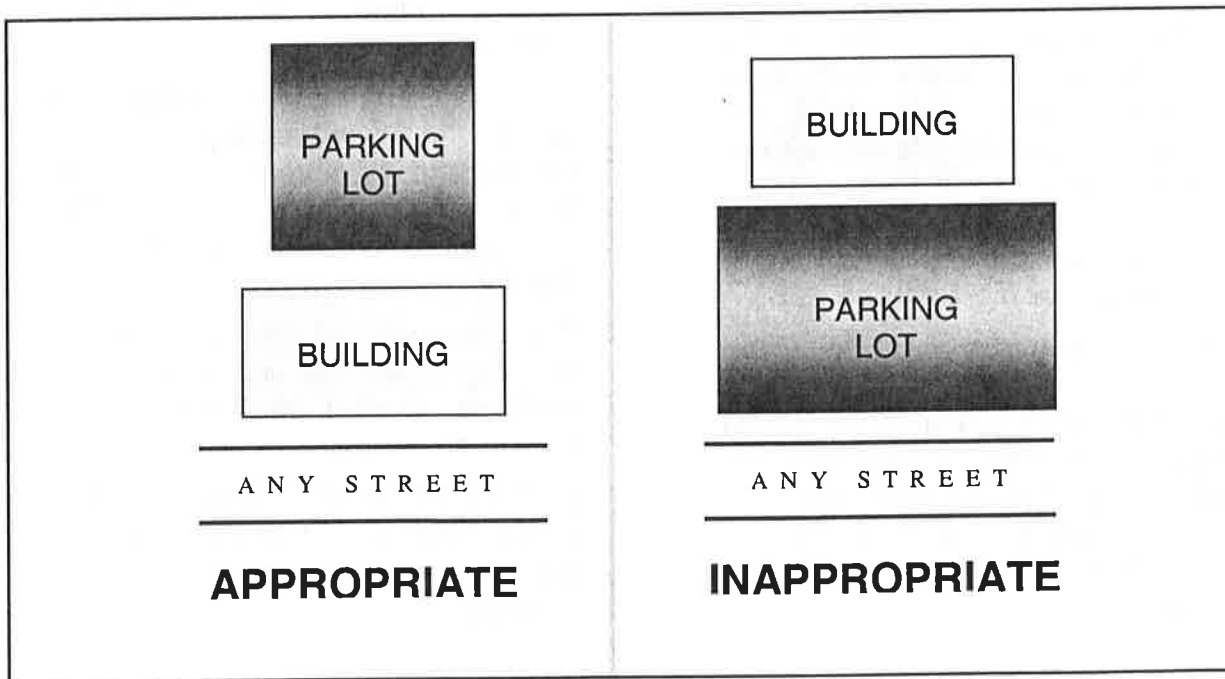

3.6 Parking Space Quantity

The total number of off-street parking spaces required for all uses or combination of uses shall be provided as specified in the Ordinance's Table of Parking Regulations. Any building or site containing more than one use shall meet the combined parking requirements for all uses, based on the area utilized for each separate use. The parking space schedule in the Ordinance represents general parking requirements acceptable to the City. Since a specific use may generate parking usage that deviates from the requirements enumerated in this Section, documentation and testimony shall be presented to the Board as to the anticipated parking. The parking requirements for any use not specifically indicated shall be determined by the Board based on evidence presented at the time of the application and based on requirements for similar type uses.

In all zone districts, except the Central Business District, (CBD Zone) in connection with every residential, commercial, institutional and industrial use, there shall be provided, at the time that any building or structure is erected, enlarged, increased in capacity or has a change of use, parking spaces in accordance with the following requirements:

- Assisted living facility*, 1 space per 2.5 rooms
- Automobile service station*, 1 space per two pumps or 4 spaces, whichever is greater
- Automotive repair shop*, 2 spaces per bay and work area

Automotive sales (indoor), 2.5 spaces per 1,000 square feet per gross floor area of interior sales space + 3 spaces per service bay

Bed & breakfast homestay, 1 space per guest room + 2 spaces per dwelling unit

Bed & breakfast guesthouses and inns, 1 space per guest room + 1 space per employee + 2 spaces per dwelling unit

Car Wash, 1 space per employee + 5 spaces per washing lane + 10 stacking spaces per lane

Community center, 4 spaces per 1,000 square feet of gross floor area

Community residence for the developmentally disabled, 1 space per employee

Family day care, 1 space per employee

Funeral home, 1 space per 200 square feet of gross floor area

Health club, 1 space per 75 square feet of gross floor area

Home Occupation, 1 space per employee + applicable RSIS requirements based on dwelling unit type

Hospital, 0.4 per employee + 1 space per 3 beds + 1 space per 5 average daily outpatient treatments + 1 space for each member of medical staff

Hotel, 1 space per guest room + 1 space per 2 employees + 1 space per 150 square feet of banquet and conference space

House of worship, 1 space per 4 seats; Every three (3) feet of a pew measured horizontally shall be considered a seat.

Laundromat, 1 space per 2 washer and dryer machines

Manufacturing and assembly, 1 space per 1,000 square feet of gross floor area

- The height of any required screen shall decrease to a maximum of three (3) feet in height where driveways approach sidewalks or walkways, in order to provide adequate visibility of pedestrians from motor vehicles and police visibility into the lot.

3.7.3 Loading areas

All loading areas, including loading dock areas of buildings and driveways providing access to the same, shall be suitably buffered and screened to minimize the impacts of noise, loading and unloading activities, lighting and glare, exhaust fumes, views of loading and unloading vehicles and other nuisances. Buffering and screening shall minimize such impacts both from within the site itself, as well as from adjacent and nearby properties and public rights-of-way, as follows:

- Buffering shall consist of a minimum ten (10) foot wide area surrounding all sides of a loading area exposed to view. Where such loading area is located on a tract adjacent to a residential use or district, such buffering shall consist of a minimum twenty-five (25) foot wide area surrounding all sides of a parking lot exposed to view.
- Screening shall consist of a minimum ten (10) foot high visually impervious screen. If such screen consists of a wall or fence, the buffer area between the wall or fence and the lot line shall be a minimum of ten (10) feet in width and shall also be extensively planted with both deciduous and evergreen trees.

3.7.4 Loading space requirements

In connection with every commercial, institutional and industrial use within all zone districts, there shall be provided, at the time that any building or structure is erected, enlarged, increased in capacity or has a change of use, loading spaces in accordance with the following requirements:

USE	TOTAL FLOOR AREA (in square feet)	NUMBER OF LOADING BERTHS
Funeral homes and Mortuaries	Up to 5,000	1
	5,000 or more	2
All other businesses and commercial uses	Up to 10,000	0
	From 10,001 to 23,999	1
	From 24,000 to 39,999	2
	40,000 or more	3
Light industrial and warehouses	Up to 5,000	2
	5,000 to 9,999	3
	10,000 to 19,999	4
	20,000 to 39,999	5
	40,000 or more	6 + 1 for each additional 20,000 square feet

3.7.5 HVAC equipment and utility service boxes

All ground level HVAC equipment and utility service boxes shall be suitably buffered and screened to minimize views of the same from both within the site itself, as well as from adjacent and nearby properties and public rights-of-way, as follows:

- Buffering shall consist of a minimum three (3) foot wide area surrounding all sides of HVAC equipment and utility storage boxes exposed to view.

3.8.2 Seasonal Outdoor Retail Sales

Temporary outdoor storage and sales of flowers, trees, and other decorative or ornamental plants is permitted from November 23 to December 27, and for a period of one (1) week prior to Easter and one (1) week prior to Mother’s Day and shall conform to the following provisions:

- Such storage and sales may not take place in any required setback area.
- No storage or sales may be conducted in a congested area, required sight triangle, or within the public right of way, where the free flow of pedestrian or vehicular traffic may be impeded or impaired. The reasonable judgment of any city police officer or the Zoning or Construction Official shall be conclusive as to whether the area is congested or whether the flow of traffic is impeded or inconvenienced.
- No storage or sales area may interfere with an existing required parking lot or area. If such storage or sales use is to be conducted from a parking lot or area, sufficient parking must be demonstrated for both the existing and proposed uses. If a site contains only the minimum number of parking spaces for the existing on-site use, seasonal storage and sales is not permitted.
- Any use of any premises pursuant to this subsection must be an accessory use to the principal permitted use of the premises.
- All stands, plants, and storage structures are to be removed within three (3) days of the date of the event.
- **Fees** — All persons wanting to conduct any outdoor sales are

required to obtain a permit from the Zoning Officer and must pay the fee required in the Ordinance.

All persons wanting to conduct outdoor seasonal retail sales as outlined in above shall also post a one-hundred dollar (\$100.00) bond with the City Clerk in order to insure that an adequate and timely cleanup is conducted.

3.9 Refuse and Recycling Areas

All non-residential uses must provide an area used for refuse and recyclable disposal collection. All containers, bins, dumpsters and/or storage facilities shall be designed to reduce discernible odors and contain such within the storage facility area. Refuse and recycling areas shall comply with the following provisions:

3.9.1 Location/placement

All storage facilities shall be located in proximity to one another or may be combined in a single common facility. Such facilities shall be centrally located and convenient for the users of the site. Designated recyclable storage facilities may be located inside a building. Such facilities shall not be located as to be visual focal points in courtyards or parking lots. Where located in a parking lot, such facilities shall not be permitted to be placed on the paved surface of the parking lot and shall be placed on a curbed area set back a minimum of two (2) feet from the curb edge of such parking lot. No refuse and recycling area may be located within a required principal building setback area.

3.9.2 Buffering and screening

All refuse and recyclable disposal collection areas shall be suitably buffered and screened to minimize the

basements, storage closets or attached garages, but shall not be situated in a hallway or corridor necessary for internal circulation or emergency access. Such area shall be designed to accommodate the average accumulated volume of designated recyclables and refuse per occupant per period of collection and any necessary storage equipment.

3.10 Parking Lot Lighting

3.10.1 Average illumination calculation

The ratio of average illumination, measured in foot-candles (f.c.), to minimum illumination, as required in the illumination requirement table, shall not exceed 4 to 1.

EXAMPLE:

If the minimum illumination required is 0.5 f.c., then the average shall be 2.0 f.c.

Minimum illumination required: **0.5 f.c.**
 Average to minimum ratio: 4:1 = (4 x 0.5) or 2.0 f.c.

3.10.2 Maximum illumination calculation

The ratio of maximum illumination provided on any site shall not exceed the minimum illumination requirement by more than a ratio of 10 to 1.

EXAMPLE:

If the minimum illumination required is 0.5 f.c., then the maximum shall be 2.0 f.c.

Minimum illumination required: **0.5 f.c.**
 Maximum to minimum ratio: 10:1 = (10 x 0.5) or 5.0 f.c.

3.10.3 Illumination levels for surface parking

Parking lots shall be adequately lighted for both motorists and pedestrians in accordance with the following table:

Minimum Illumination for Surface Parking

ACTIVITY TYPE	VEHICULAR TRAFFIC (f.c)	PEDESTRIAN SAFETY (f.c)	PEDESTRIAN SECURITY (f.c)
Low activity	0.5	0.2	0.5
Medium activity	1.0	0.5	1.5
High activity	1.5	0.9	2.5

3.10.4 Parking lot lighting-fixture mounting height

In non-residential zone districts, lighting shall be provided by fixtures with a mounting height not more than twenty-five (25) feet or the height of the building, whichever is less, measured from the ground level to the centerline of the light source. Lighting in residential zone districts shall be provided by fixtures with a mounting height of not more than fifteen (15) feet.

3.10.5 General provisions

Any other outdoor lighting such as building and sidewalk illumination, driveways with no adjacent parking, the lighting of signs and ornamental lighting, shall be shown on the lighting plan in sufficient detail to allow a determination of the effects upon adjacent properties, traffic safety and overhead sky glow. The objective of these specifications is to minimize undesirable off-premises