



Leathercraft

4-H MANUAL

Revised 12.2022



COLORADO STATE UNIVERSITY
EXTENSION

4-H Leathercraft Manual

Acknowledgements

This revised 2023 edition of the Leathercraft manual was compiled by the following contributors. Special appreciation is expressed for the extensive effort given to the revisions.

Teddi Baird-Tharp, 4-H Leathercraft Leader, La Plata County
Tearle Lessenden, Area Extension Agent – 4-H Youth Development, Agriculture, Natural Resources, Kiowa County, Southeast Region
Jim Linnell, Elktracks Studio, Venus, Texas
Kay Orton, 4-H Leathercraft Leader, Mesa County
Lisa Sholten, State Specialist, 4-H Youth Development, Civic Engagement & Curriculum
Joe Talbott, 4-H Leathercraft Leader, Pueblo County

The 2011 and 2012 contributors who did not all participate in this revision also deserve acknowledgment for the portions of their work that have been preserved: Clare Shier, Boulder County, Jean Steinhoff, Don Olander, Larimer County; Elsie Rewerts, Logan County; Kay Orton, Mesa County; Steve Cramer, Logan County; Bill Hutley, Adams County; Maurie Paul, Jefferson County; Jason Skillingberg and Ron Vallejos formerly with Tandy Leather Company.

Special appreciation is expressed to Tandy Leather Company, Weaver Leather Supply, and Elktracks Studio for permission to use illustrations from their publications and other creative assets. Thanks also to Joanne Burney, Robin Nielson and Vicki Mayea for their artwork used in the previous manuals that has been carried over to this newer edition.

Revised: 12/1986, 12/2011, 01/2012, 01/2023



**COLORADO STATE UNIVERSITY
EXTENSION**

Colorado State University, U.S Department of Agriculture and Colorado counties cooperating. To simplify technical terminology, trade names or products and equipment occasionally will be used. No endorsement of product names is intended nor is criticism implied of products not mentioned.

Colorado State University Extension is an equal opportunity provider. Colorado State University does not discriminate on the basis of disability and is committed to providing reasonable accommodations. CSU's Office of Engagement and Extension ensures meaningful access and equal opportunities to participate to individuals whose first language is not English. <https://col.st/OWMJA>

Colorado State University Extension es un proveedor que ofrece igualdad de oportunidades. Colorado State University no discrimina por motivos de discapacidad y se compromete a proporcionar adaptaciones razonables. Office of Engagement and Extension de CSU garantiza acceso significativo e igualdad de oportunidades para participar a las personas quienes su primer idioma no es el inglés. <https://col.st/OWMJA>

Table of Contents

| | |
|---|----|
| 4-H Leathercraft Manual Acknowledgements | 1 |
| Table of Contents | 2 |
| Leader Information | 6 |
| Experiential Learning Process | 6 |
| Targeting Life Skills | 7 |
| 4-H Thriving Model | 8 |
| Chapter 1-All About Leathercraft | 9 |
| History of Leather | 9 |
| Leather Sources | 11 |
| Leather Structure..... | 12 |
| Leather Tanning | 14 |
| Leather Definitions..... | 15 |
| Leathercrafting Definitions | 16 |
| Chapter 2-Preparation of Leather for Stamping | 18 |
| Stretch Prevention..... | 18 |
| Casing Your Leather..... | 19 |
| Gathering Basic Tools | 21 |
| How to Create a Stamping Design | 21 |
| Chapter 3-Using Creative Stamping Tools | 23 |
| Basic Beginner Stamping Tools..... | 23 |
| The Mallet | 23 |
| Stamping Examples..... | 24 |
| 3-D Stamping Tools..... | 27 |
| Chapter 4-Traditional Floral Carving and Tooling | 29 |
| The Tracing Pattern | 29 |
| Transferring Your Design on to the Leather..... | 30 |
| Swivel Knife..... | 31 |
| How to Cut the Design..... | 36 |
| The Camouflage..... | 37 |
| The Pear Shader | 38 |
| The Beveler..... | 39 |

| | |
|---|-----------|
| The Veiner and Seeder | 40 |
| The Backgrounder | 41 |
| Decorative Cuts | 42 |
| Chapter 5-Carving Techniques and Styles | 43 |
| Inverted Technique | 43 |
| Silhouette Technique | 45 |
| Rough-out Technique | 46 |
| Filigree Work | 47 |
| Figure Carving | 51 |
| Regional Styles | 55 |
| Pictorial Carving | 56 |
| Framing and Mounting Pictures | 57 |
| Chapter 6-Preparing Leather for a Finish | 58 |
| Cleaning Leather | 58 |
| Edge Finishing | 58 |
| Edge Beveling | 58 |
| Edge Burnishing | 59 |
| Chapter 7-Coloring for Leather | 60 |
| Products for Coloring Leather | 60 |
| General Suggestions for Coloring Leather | 61 |
| Antique Finish/Two Tone Finish | 62 |
| Background Dyeing | 63 |
| Solid Color Dying | 64 |
| Block Dyeing | 65 |
| Alternative Techniques for block Dyeing | 65 |
| Shade Dyeing | 66 |
| Special Shading Techniques | 67 |
| Air Brush Dyeing | 68 |
| Painting Leather | 68 |
| Chapter 8-Finishes for Leather | 69 |
| Applying Finish | 69 |
| Kinds of Finishes | 69 |
| Chapter 9-Shaping and Modeling Leather | 70 |

| | |
|--|-----------|
| Shaping and Molding Leather | 70 |
| Sculpting Leather..... | 71 |
| Collages | 71 |
| Chapter 10-Leather Fabrication | 72 |
| Leather Cutting Tools | 72 |
| Setting Rivets | 72 |
| Domed or Double Cap Rivets | 72 |
| Tube Rivets | 73 |
| Copper Rivets..... | 73 |
| Setting Snap fasteners (Segma Snaps)..... | 74 |
| Setting the Cap and Socket..... | 75 |
| Setting the Stud and Eyelet | 75 |
| Installing Leather Linings and Gluing | 76 |
| Skiving Tools | 77 |
| Using the Skiving Tool..... | 77 |
| Gouging Tools | 78 |
| Using the Gouging Tool..... | 78 |
| Using Hole Punches | 80 |
| Revolving Punch | 80 |
| Drive Punch..... | 80 |
| 4-IN-1 Punch | 81 |
| Punching Lacing Holes | 82 |
| Chapter 11-Structural Assembly Techniques | 83 |
| Basic Leathercraft Lacing | 83 |
| Items Needed for Lacing | 83 |
| Amount of Lacing Required | 83 |
| Preparing of Item for Lacing | 83 |
| Lacing Chisels | 84 |
| Punching Holes with Lacing Chisel..... | 84 |
| Measuring Lace | 87 |
| Two-Prong Lacing Needle | 88 |
| The Life-Eye Lacing Needle | 89 |
| Types of Lacing..... | 89 |

| | |
|---|------------|
| Whip Stitch Lacing | 90 |
| Running Stitch Lacing | 92 |
| Buckstitching | 93 |
| Single-Loop Lacing | 98 |
| Double Loop Lacing | 100 |
| Hand and Saddle Stitching | 103 |
| Chapter 12-Construction and Braiding Leather | 107 |
| Expanded Leather | 107 |
| Braiding | 109 |
| Collages and Other Art Forms | 111 |
| Chapter 13-Sewing Leather | 112 |
| Equipment and Supplies | 112 |
| Selecting Patterns and Leather | 113 |
| Cutting and Sewing | 113 |
| Machine Stitching | 114 |
| Seams | 114 |
| Darts | 115 |
| Hems | 115 |
| Linings | 115 |
| Chapter 14-Making and Rebuilding Saddles | 116 |
| References and Resources | 118 |
| Appendix | 119 |
| Beginner Patterns | 119 |
| Intermediate Patterns | 129 |
| Advanced Patterns | 131 |

Leader Information

Experiential Learning Process

The 4-H program utilizes a process where adult leaders ask open-ended questions that challenge youth to think. Through this inquiry, youth can propose hypotheses and determine their own solutions. The Experiential Learning Model developed by Pfeiffer and Jones (1985) and modified by 4-H includes five specific steps that can be summarized into three main processes: Do, Reflect, and Apply.

The Experiential Learning Model encourages discovery with minimal guidance from others. A situation, project or activity is undertaken for individual thought and problem solving. Minimum outside assistance is provided, but support is offered to the individual by questioning at each stage. The youth participating in an activity reflect on what they did, and then assess how what they learned can be applied to a life situation. Below are questions that might help during each stage of learning.

1) Experience (Doing)

Questions: What sources of information are available? What is possible? What do you expect to see? How is it working? What else might you try?

2) Share (Reflecting on What Occurred)

Questions: What was your goal for this project/activity when you began? What happened? What were the results? What was most difficult? How do you know? What did you learn? What surprised you? How did you share this project/activity with others?

3) Process (Reflecting on What's Important)

Questions: What problems seemed to reoccur? How did you solve them? What similar experiences have you had? How was the experience like or unlike experiences others had? Would you do anything differently? What did you learn about making decisions? What suggestions would you have for someone else who wanted to do a similar project/activity? What life skills were you developing through your project? Why are life skills important? What new questions do you have about yourself, others, and future goals?

4) Generalize (So what?)

Questions: What did you learn about yourself or about the activity? What key points have you learned? How did you decide what to do? What else could you have done? How does this relate to something else in life? Where have you faced similar challenges in your life? Where might this situation occur in the future? Why is it important to have plenty of information before making decisions? What did you learn about your own skill in communicating with others?

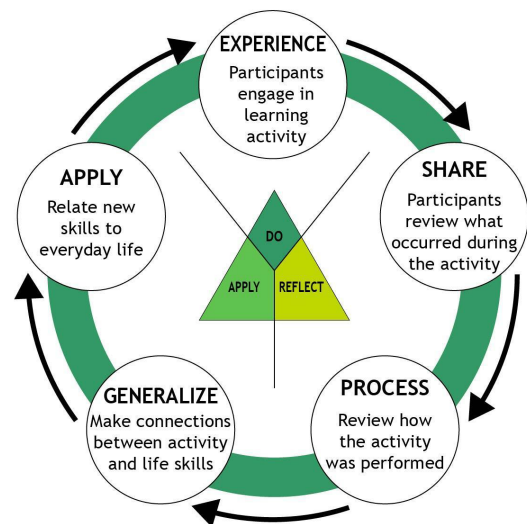

5) Apply (Now what?)

Questions: How does this project/activity relate to your everyday life? Why is this project/activity important to you? Where else can this skill be used? How will you use this in the future? What will you do differently after this experience? How can I make an impact? What will I create next? In what ways do people help each other learn new things? What are qualities you think are important in a leader? If someone helped or mentored you in this project, what would you tell them you learned and what difference it has made in your life? How would you express your appreciation?

Targeting Life Skills

A skill is a learned ability. Life skills are those abilities that assist individuals to lead successful, productive, and satisfying lives. In 4-H, we use the Targeting Life Skills Model to help youth become competent and prepared for adulthood. The Targeting Life Skills Model categories are based on the four H's from the 4-H clover (Head, Heart, Hands, and Health). Under each of these main categories, there are two general skill levels and eight subcategories listing specific skills youth learn in 4-H.

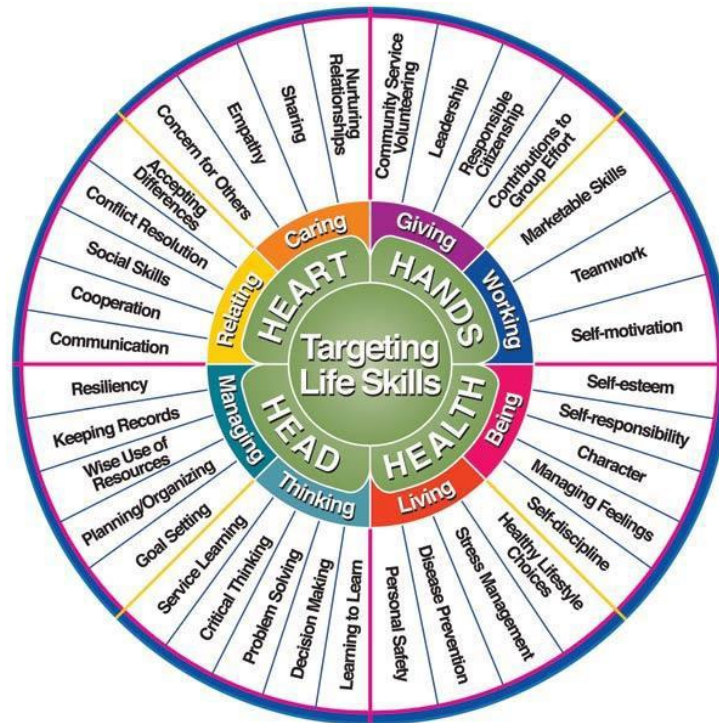

Image: Hendricks, P. (1998) "Developing Youth Curriculum Using the Targeting Life Skills Model" <http://www.extension.iastate.edu/4H/skls.eval.htm>

The main goal in 4-H positive youth development is to provide developmentally appropriate opportunities for youth to experience life skills and to be able to use them throughout a lifetime. By understanding the importance of the 4-H framework and its structure, 4-H members, parents, professionals, and leaders will know the expectations and will be able to effectively use 4-H delivery methods to help youth learn these life skills.

4-H Thriving Model

The 4-H Program Leaders' Working Group developed the 4-H Thriving Model to advance and support the accomplishment of the 4-H Youth Development 2025 National Strategic Plan. They describe the 4-H Thriving Model as follows:

The 4-H Thriving Model illustrates the process of positive youth development in 4-H programs by connecting high quality program settings to the promotion of youth thriving. High quality 4-H program settings provide youth a place to belong, matter and explore their personal spark. High quality settings foster developmental relationships with youth, relationships that express care, challenge growth, and share power. These components help ensure that 4-H programs provide a nourishing developmental context – a place where youth can belong and grow.

High quality 4-H programs contribute to Positive Youth Development (PYD) through the intentional promotion of social, emotional, cognitive, and behavioral habits of mind. In the 4-H Thriving Model this process of PYD is described by seven indicators of thriving: Openness to challenge and discover, growth mindset, hopeful purpose, prosocial orientation, transcendent awareness, positive emotionality and self-regulation through goal setting and management.

Youth who experience high quality developmental settings in 4-H with an emphasis on these key social-emotional skills achieve key positive youth development outcomes, including academic motivation and success, social competence, high personal standards, connection with others, personal responsibility, and contribution to others through leadership and civic engagement.

Youth who achieve positive developmental outcomes are more likely to also achieve long-term outcomes marked by vocational or academic success, civic engagement, employability and economic stability and happiness and well-being. (Learn more at <https://helping-youth-thrive.extension.org/>.)



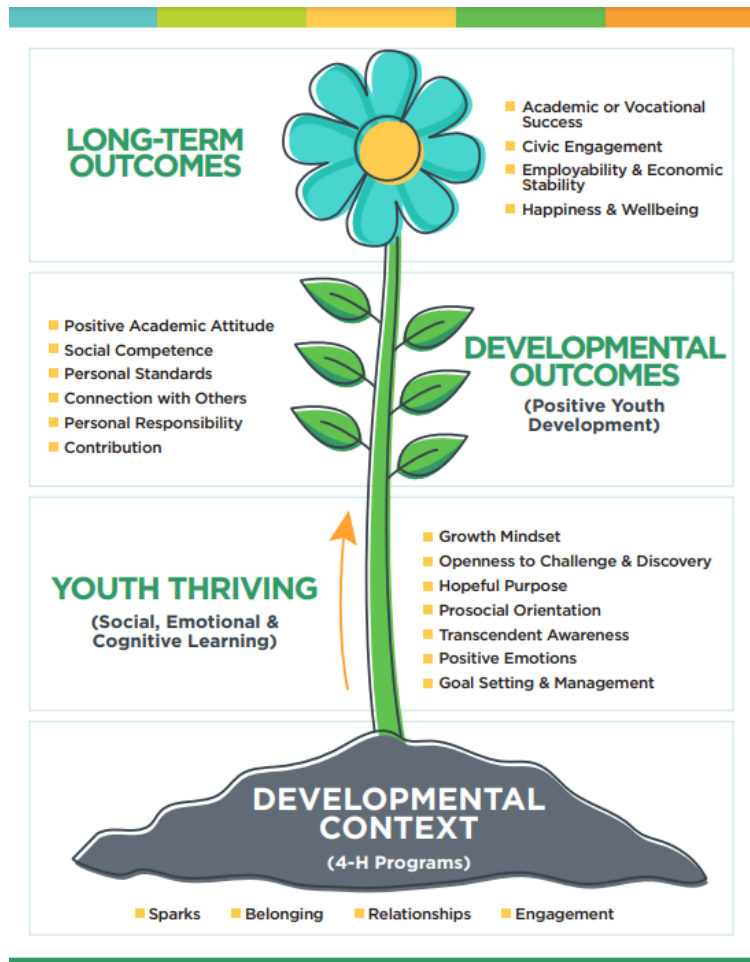

Additional information and activities are in the accompanying Leathercraft Leader Guide.







Chapter 1—All About Leathercraft

History of Leather

Eons ago, hunters found the animals they killed for food could provide them with sandals and garments by simply curing and fashioning the skins. For centuries, leather has continued to serve humans with each generation of people contributing something to the craft through technology and ingenuity. The table below outlines contributions to the art and uses of Leathercraft from various peoples and eras throughout time.

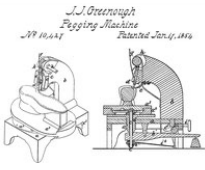





| Era/Contributions | Uses/Contributions to Leathercraft |
|--|---|
| Cavemen  | Chose to wrap hides around their feet to prevent bruising and soreness creating the first shoes. Cavemen also used hides to create clothing and blankets. |
| Ancient Hebrews  | Believed to be the first people to use tanning to cure skins and keep them from rotting, allowing the leather to last for many years. |
| Egyptian  | Used beautiful jewels and other decorations to create leather sandals that have been discovered in ancient tombs, some over 3,000 years old. |
| Romans  | Centurions used shields of decorated leather for protection. Romans also used leather as money because they believed it had great value. |
| Middle Ages  | Leather Guildsmen closely guarded their art and as a result leather products could only be afforded by the wealthy. It was during this time that leather also became a source for creating pages for books or stationary as man realized the importance of writing things down. |



| | |
|--|---|
| <p>Native Americans</p>  | <p>Tanned deer, buffalo, bear, and other animals to make moccasins, clothing, vests, headbands, tepees, and other items. Native Americans discovered that smoking the leather would make it waterproof. The Native Americans taught early settlers to tan deerskins and create buckskin clothing.</p> |
| <p>Pioneers</p>  | <p>Learned tanning and uses of leather from Native Americans and spread the knowledge throughout the west. The "cover" of a covered wagon was a special leather tarp and the harnesses used were also leather.</p> |
| <p>Conquistadors</p>  | <p>Brought horses to the Americas and the saddle makers followed. Spanish tack makers were the first to use floral designs in leatherwork.</p> |
| <p>Shoe-Pegging Machine</p>  | <p>Created in 1851, this machine took Leathercraft from art to industry by allowing mass production of leather shoes. Today American shoemakers turn out 5,000 pairs of shoes every minute.</p> |
| <p>Nuclear Scientists</p>  | <p>Needed specialized gloves or gauntlets to protect their hands from burns, so a special leather glove was designed.</p> |
| <p>Astronauts</p>  | <p>Pressurized leather suites, based on early flight suits designed to keep pilots warm and durable, were worn by early astronauts to go into space.</p> |

Leather today is wherever we are. All of us use leather in shoes, belts, handbags, watches, wallets, key cases, vests, jackets, gloves, and many other items, such as furniture and car interiors. And that is not to mention sports, where baseballs, softballs, golf balls, basketballs and baseball gloves are all made of leather.

Leather Sources

So where does all this leather come from? In most cases leather is a byproduct of meat processing where the animal is slaughtered for food, and the skin is preserved to become leather, but this may not always be the case. The table below includes the most common sources for leather and their relative uses.

| Source | Uses |
|---|---|
| Cattle  | Most leather comes from cattle. The skin, called cowhide, is used for shoes and other heavy leather articles. |
| Calves  | Calf skin is used for thin items like coin purses and billfolds. |
| Sheep and Lambs  | Sheepskins and lambskin are used for clothes and gloves. Many of the skins come from New Zealand. Lambskin with the wool left on is used for coats. |
| Pigs  | Pigskin from South America is used for gloves, wallets, and shoes. |
| Horses  | Horsehide is used for sporting goods. |
| Water Buffalo  | Water buffalo, from Asia, provide strong leather for boots. |
| Shark  | Shark skin is strong for small leather goods and specialty boots. |

| | |
|--|--|
| <p>Reptiles</p>  | <p>Snake, alligator, and lizard skin are used to make fancy leather goods, most common are purses, jackets, boots and hat bands. This type of leather may not be tooled.</p> |
| <p>Elk or Deer</p>  | <p>Elk hide and deerskin are used much as they were by the Native Americans in making clothing, gloves and moccasins.</p> |

Leather Structure

The complete hide of an animal is known as a skin. The skin is made up of the following structures:

- hairs, which consist of a protein called keratin (Hairs and keratin are removed from leather by soaking the hide in a solution of lime and by applying unhairing agents like sodium hydroxide and calcium hydrosulfide. The hair can then be removed first with a machine and then by hand using a dull knife prior to the tanning process.)
- epidermis, a protective layer of keratinous cells that gives the skin strength and flexibility
- sweat glands, which discharge sweat through the pores of the grain
- sebaceous glands, which are at the side of hair follicles and discharge a waxy oily substance to protect hair
- corium, a network of collagen protein fiber, which is the strongest part of the skin (towards the center, fibers are coarser and stronger)
- flesh, which is next to the meat where fibers are more horizontal and fatty tissue may also be present

The skin may be left whole or cut into sections such as sides, bellies, or backs. Smaller animals (calves, goats, sheep) are usually tanned as a skin or full hide. Leather is usually sold by the square foot. For easier handling, large animal hides are usually cut in half. A side of leather is just that, one "side" or one half of a hide.

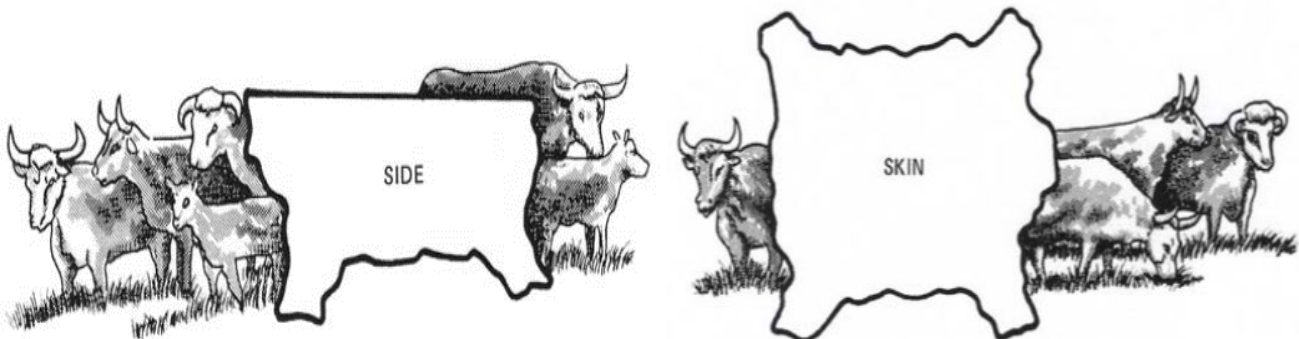

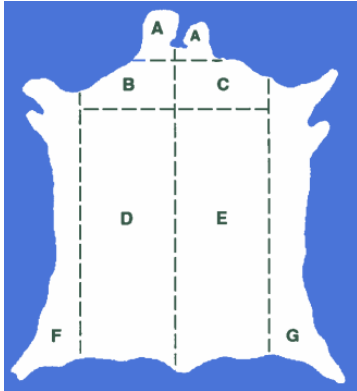

In the processing of hides from large animals, it is customary to cut them into two or more smaller sections for easier handling. The names of the various parts in the chart are shown below.

- A - Head
- B or C - Shoulder
- D or E - Bend
- F or G - Belly
- A+B+D+F or A+C+E+G - Side
- A+B+D or A+C+E - Crop
- B+D or C+E - Back
- D+E - Croupon

The thickness, or weight, of leather is usually measured in terms of ounces. One ounce equals approximately 1/64th of an inch in thickness. To make leather a uniform thickness, hides are run through special splitting machines. Since animal hides are not of a uniform thickness and wet when put through the splitting machine, the thickness of leather will not remain the same throughout the hide. There will always be slight variations and that is why leather weights seldom measure out in exact 64th's of an inch.

Leathers are usually shown as 4-5 ounces, 6-7 ounces, etc. Some leathers are also gauged in millimeters. For example:

| Weight of Leather in Ounces | Approximate Thickness in Inches | Approximate Thickness in Millimeters | Common Uses |
|-----------------------------|---------------------------------|--------------------------------------|--|
| 1 ounce | 1/64 of an inch | 0.4mm | Linings, book bindings |
| 2 – 3 ounces | 1/32" – 3/64" | 0.8 – 1.2mm | Molding, toolable linings, embossing |
| 4 – 5 ounces | 1/16" – 5/64" | 1.6 – 2mm | Embossing, wallet backs, organizers, clutch purses |
| 6 – 7 ounces | 3/32" – 7/64" | 2.4 – 2.8mm | Small cases, notebook covers |
| 8 – 9 ounces | 1/8" – 9/64" | 3.2 – 3.6mm | Carved purses, camera cases, journal covers |
| 10 – 11 ounces | 5/32" – 11/64" | 4 – 4.4mm | Belts, knife sheaths, holsters, saddle bags |
| 12 – 13 ounces | 3/16" – 13/64" | 4.8 – 5.2mm | Saddles |
| 14 – 15 ounces | 7/32" – 15/64" | 5.6 – 6mm | Saddles |

Lighter weight leathers, such as calfskin, range from 1 ½ ounces to 3-4 ounces. Heavier leathers, 4-5 ounces to 10-11 ounces and more come from the hides of mature cattle.

The "flesh" side of the leather is the underpart that was next to the meat and flesh of the animal. The hair side, called the "grain" side, is most commonly used for carving and stamping. Its fiber

structure is more closely knit and easier to cut. When carving and stamping tools are used properly, the grain side will retain even the tiniest details.

The grain side has a "grain layer" of about one-fifth the thickness of the hide. The rest of the hide consists of a honeycomb fibrous structure that works like interlacing hinges or scales. During tanning, fats and oils are added to this honeycomb structure to make the grain side leather soft and workable.

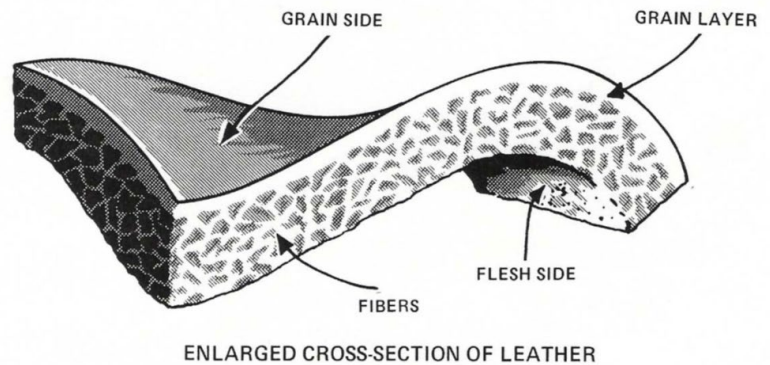

Leather Tanning

Leather is unique, different from any cloth put together by man, for it is the actual skin of an animal that grew as the animal grew. To change this skin into leather, the skin must be tanned. Various methods of tanning produce leather for different purposes. The two main ways of tanning leather are chrome tanning and vegetable tanning.

| Chrome Tanning | Vegetable Tanning |
|--|--|
| <p>Why? Chrome tanning is fast. It takes less time than any other tanning.</p> <p>How? Animal skins are washed in strong chemicals to make the skin strong.</p> <p>How can you tell? If leather is chrome tanned, when you cut into it the inside will be a bluish white color.</p> <p>What for? Chrome tanned leather is used mostly for shoes, or as with reptile leather, for purses and belts.</p> | <p>Why? Vegetable tanning creates leather that will absorb moisture readily, allowing leather to be easily molded and formed.</p> <p>How? Animal skins are put in big deep tubs that hold several kinds of tree bark, water, and chemicals. It takes over three months for the leather to cure with this method.</p> <p>Where does it come from? The most common leather that is vegetable tanned is from cattle and is commonly called "strap" leather.</p> <p>What for? Leather to be hand-tooled, carved, or stamped, must be vegetable tanned.</p> |

Another common type of tanning is oil tanning, which is the process of tanning with animal oils. Oil tanning is used in the manufacture of certain very soft and pliable leathers, particularly chamois and certain kinds of buckskins. Fish oil is generally used in oil tanning. In addition, Latigo Leather is cattlehide leather tanned with a combination of alum crystal and gambier. Gambier is a kind of dried sap derived from extracts of squeezed leaves and twigs of plants with the same name (*Uncaria Gambier Roxb*) used as a vegetable tanning agent. Latigo leather is used for cinches, ties, saddle strings, and other saddlery work.

Leather Definitions

Alligator: Genuine alligator comes in several different shades of brown and mahogany; skins range from 14" wide to 60" long; generally used for billfolds and handbags; cannot be tooled.

Back: A side with the belly cut off, usually 15 to 18 square feet.

Belly: The lower part of a side, usually 6 to 10 square feet.

Calfskin: Comes in all colors and ideal for tooling; range from 10 to 14 square feet.

Chrome Suede: Taken from the flesh side split off a cowhide.

Cowhide: Ideal for tooling and constructing items that must withstand hard wear, such as belts; range from 20 to 25 square feet.

Elkhide or Deerskin: Used for moccasins or belts; comes in natural and brown; range from 18 to 22 square feet.

Full Grain: Leather just as it is when taken off the animal, only the hair has been removed.

Genuine Sharkskin: Breathable, yet water-repellent; has unusual grain surface; used principally for shoes, boots and belts.

Grain: Epidermis or outer layer of animal skins.

Lambskin: Comes in the form of suede or may have embossed grains to look like alligator, ostrich, or other fancy design; used for linings, purses, and belts; range from 7 to 9 square feet.

Lizard: May be found in all colors; is not toolable; skins are small, ranging from 9 inches long to 17 inches wide.

Natural Lamb: Used for linings. Suitable for tooling in the heavier weight and has natural color.

Oil Tan Leather: A type of chrome tanned leather that has had additional oils and/or waxes added to make it more weather resistant.

Ostrich: Beautiful leather but generally expensive; may be russet, brown, and black; range from 10 to 14 square feet.

Pigskin: May be tooled, but it is not recommended; comes in natural or black; range from 12 to 20 square feet.

Shearling: A sheepskin washed and tanned with the wool left on, then clipped to desired length, usually ¼ to 1 inch.

Sheepskin: Comes in the form of suedes, and embossed grains; comes in all colors; range from 7 to 9 square feet.

Side: One half skin or hide, usually 22 to 26 square feet.

Skin: Leather tanned in the whole pelt, same size and shape as it came from the animal.

Split: This refers to the under sections of a piece of leather that has been split into two or more thicknesses.

Steerhide: The best tooling leather next to calfskin; comes in natural or two-tone colors and in different weights; range from 20 to 28 square feet.

Suede: A finish produced by running the surface of leather on a carborundum or emery wheel (sanding) to separate the fibers to give the leather a nap. Used for bags, bag linings, pillows, jackets, skirts, and garments of all types.

Top Grain: Not the same as full grain – has often been sanded to remove scars and is then sprayed or pasted to "cover up".

Leathercrafting Definitions

Background dyeing: Dyeing a solid color to the area tooled with the backgrounder.

Carving: Is where you cut into the leather (usually with a swivel knife) as part of the design you are tooling.

Clear finish: Is a top finish for tooling leather that has no color in it to protect leather. Some are waterproof, and some are not. For example, oil (no color added), leather finish spray or wipe (no color).

Color shading: Is using shades of color to make the design look more realistic. For example, use darker and lighter shades of a color on a tooled flower, animal, or figure of any kind to make it look more realistic. Paints will be accepted.

Decorative swivel knife carving: Is carving a pattern that just uses the swivel knife to make a line drawing. Shading is done with more lines (hatching).

Figure carving: Is the carving of figures (i.e., persons, animals, objects, etc.)

Harness needle: Is a needle with a blunted point and diamond awl or a three-cornered glover's needle for hand sewing.

Lace: Is flat with a shiny side and a rough side.

Pictorial carving: Is the adding of background areas (i.e., trees, fence, mountains, grass, etc.) to the carving to make the picture complete. (Note: All pictures meant to be hung need to be complete with hardware to hang for display, whether framed or not.)

Rotary Punch: This tool is used to cut an eyelet hole for eyelet application, decorative lacing or keyhole buttonholes. An awl, hole punch or eyelet punch also may be used.

Sewing thread: Is round thread, waxed or not.

Solid color dyeing: Is dyeing the whole project the same color. For example, tool a belt and then dye it all black or make a book cover and dye it all one color.

Staining/Antiquing: Will add a little color and bring out and enhance cuts, tooling and stamping. Usually, it is a cream that is applied and wiped off.

Stamping/Tooling: Is where you use impressions made from tools to form a design.

Thread: Machine stitch with cotton wrapped polyester core thread. Five cord linen thread is good for general hand stitching.

Traditional carving: Includes floral, scrolls, oak leaf, maple leaf type patterns.

Two tone finish: Is a technique where an area has a clear finish, which will give a two-tone effect after an additional antique finish is applied.



Look for Quick Tips in this manual to give you ideas for working that experienced leathercrafters have found helpful.

Chapter 2—Preparation of Leather for Stamping

Leather For Your Project

Leather may be purchased in several ways. Large skins or sides may be purchased by the square foot or pre-cut pieces and kits are readily available. If you cut your own leather, you will need to punch lacing holes in your own pieces. Small pieces of hides can also be purchased. Some kits come with pre-punched lacing holes, and some come unpunched, so you can choose your own stitches and punch accordingly.

Some great items to begin with are rounders, conchos, rectangles, hearts, shields, ovals, a hexagon, and stars. These items are great for practice stamping and can be turned into bookmarks, coasters, or key chains. You can purchase remnant bags that contain scrap pieces of leather ideal for practice stamping and cutting. You will need leather to practice designs before you make your final article.

Complete kits may also be purchased for constructing specific items. If you prefer to purchase large pieces of leather and cut your own shapes, there are a variety of tools available to help you. The type of tool needed for cutting leather depends largely on the thickness of the leather piece. **(Refer to chapter 1 for helpful information on leather.)** The most common cutting tools are shears (leather scissors) rotary cutters and craft knives. Shears are probably best for beginners to use. Follow manufacturer's instructions on all cutting products. **Always use a good cutting surface** to cut leather on. Some good cutting surfaces are poly cutting boards, rubber cutting boards, or a wood cutting surface.

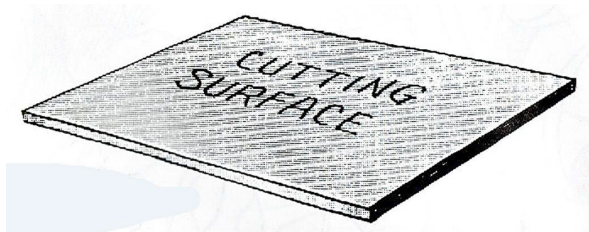

Stretch Prevention

Before you can put a design on leather, you must dampen or “case” the leather. As the leather becomes damp, the fibers will swell and soften. Vegetable tanned leather, properly moistened, is like modeling clay. You can mold it, make impressions in it, and shape it. It becomes a little stretchy and as you make impressions in it the leather with tools and the leather may become stretched out of shape. The thinner the leather, the more it stretches. Thicker leather is less likely to stretch.

There are several ways to prevent leather from stretching while stamping the design. Efforts to keep the leather from stretching must be done **before** the leather is dampened.

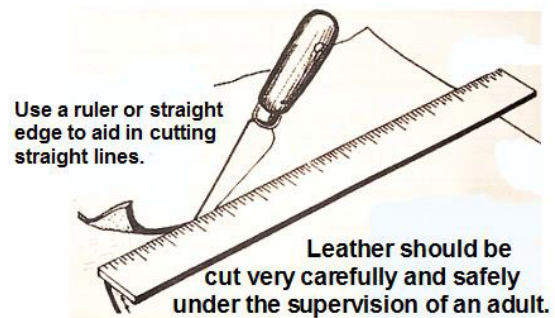

One way to prevent stretch is to apply a light coat of rubber cement to the flesh side of leather and to cardboard (use hard finished cardboard for easy removal of leather after stamping). Allow cement to dry and then adhere in place.

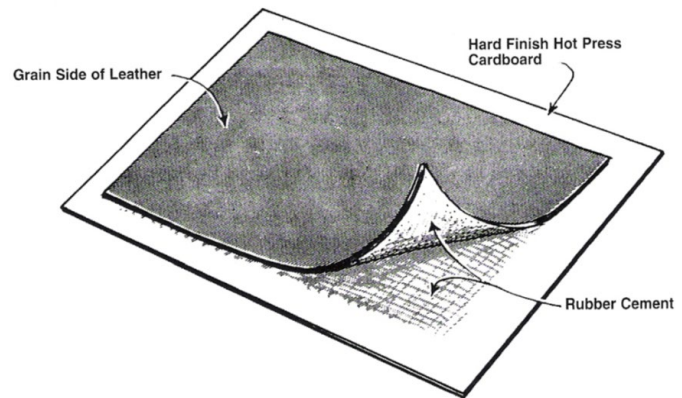

Case the leather and stamp the design.

Let the leather dry. To remove cardboard from the leather, place the leather stamped side down on a bench and peel the cardboard from the leather. Hold the leather as flat as possible so that it does not wrinkle when removing cardboard. If you do not intend to line your finished project, lightly sprinkle the flesh side with talcum powder to remove tackiness.

You can also use packaging tape to prevent stretch (works well instead of rubber cement) and it is easier to remove and usually does not leave residue behind. To prevent stretching by using **painters' tape**, **clear packing tape**, or **masking tape** (not duct tape), tape the entire back of the area to be tooled or the back of the whole project. You can double tape it if necessary for it to be flat and hold its shape. After tooling, let the project dry. Then pull the tape off the back of the project. Again, hold the leather as flat as possible as to not wrinkle, scar or scratch leather when removing the tape.



Tip: It is best practice to wash your hands and have a clean work area before you begin, so no oils or dirt get on the leather.

Casing Your Leather

Casing is a term used to describe the application of moisture to leather so tool impressions can be stamped into the leather surface. Before you can work leather, you must moisten it with water. As you wet the leather, the fibers swell and soften. Vegetable tanned leather, properly moistened, is like modeling clay. You can mold it, model it, and shape it.

Always use glass, porcelain, plastic or enameled containers for water—NEVER use metal containers as contact with metal may cause dark stains on your leather.

To case your leather, rub a DAMP (not wet) sponge or use a fine mist spray bottle to apply water to the flesh side (rough side) of the leather as evenly as possible. Then turn the leather over and dampen the grain side (tooling surface). Water will darken the leather.

More water is used on thicker leather than thinner leather. Sometimes thin leather only needs to be dampened on the grain side.

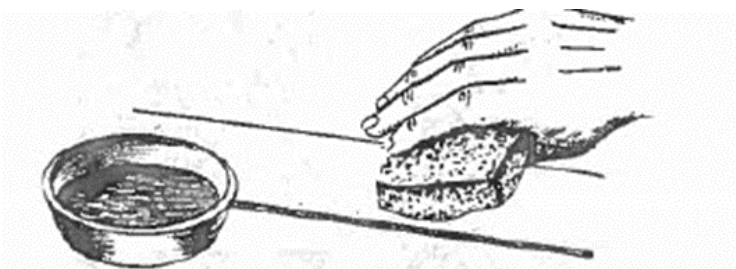

QUICK TIPS

Tip: Be sure to dampen your leather, so the moisture is about $\frac{1}{3}$ of the way through the thickness of the leather on the grain side. The leather should feel cool to the touch. The color of the leather may also change.

Note: For best results, place the leather in a plastic bag and allow it to case overnight before stamping or carving. Place it in the refrigerator to prevent mold from growing on the leather.

The article will be ready to stamp and mark or trace guidelines for your design when the moisture soaks into the center of the leather and dries from the surface of the leather. When it begins to return to its natural color, begin stamping. If areas begin to dry before you are finished, simply wipe your sponge over them or lightly spray to keep them damp.

Your best guide for moistening leather is practice. Your stamping tools will imprint clearly and firmly into the leather ONLY when you have moistened the leather to the proper degree. **When it is too wet**, the tools will sink deep and could potentially cut through; **when it is too dry**, the tools will only leave scratches that mar your leather.

If it is dry, it will feel warm. If it is damp, it will feel cool, and that's when you can begin stamping the leather. You can also try testing the leather by holding it gently against your cheek to feel the temperature. With practice you will soon know instinctively when to begin stamping.

If you must leave your leatherwork for an hour or so, hold and preserve the moisture content by covering it with a clean plastic bag or piece of plate glass. This will retain the moisture for several hours and the leather will be in perfect condition to continue stamping when you return.

QUICK TIPS

Be careful—storage of damp leather for a prolonged time can cause mildew. Dampened leather can be stored in a plastic bag in the refrigerator to avoid mold and mildew.



CAUTION: Always use a glass, porcelain, or enameled container for water. NEVER use metal containers. The slightest contact with these will produce dark stains on your dampened leather, stains that are almost impossible to remove. Be careful to keep all filings or steel dust from grinding wheels, etc., completely away from your leather. Unnoticed by you until you have dampened your leather, such particles will mar or stain your leather.

Water can also stain leather. It is possible for a few drops of water to accidentally spill on a piece of leather and go unnoticed. If allowed to dry it could cause a definite stain and create dark spots on your project that cannot be removed. If water is dropped onto dry leather, moisten the entire piece at once. Apply more moisture to the spotted area with a sponge, fading out the surrounding area. Enough moisture must be applied to the spotted area to render it invisible, or the spot will always remain. Basically, the area surrounding the spot must have an equal amount of moisture added so that when the entire piece dries, the spotted area will dry unnoticed.

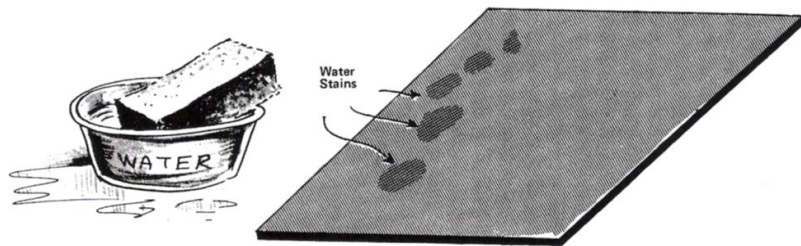

Gathering Basic Tools

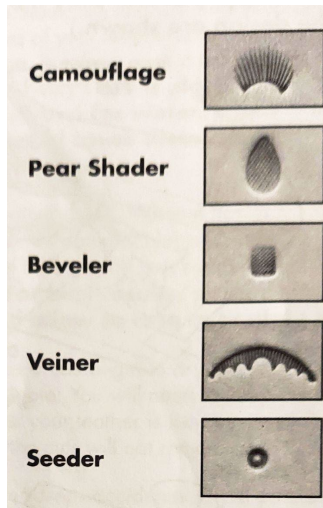

There are many kinds of stamping tools available. Some tools have a specific letter and number on the back edge of the handle to identify it. For example, a veiner from Tandy Leather might be marked V406. This means that it is a specific shape or size that is different from other veiners and can be identified. Some designs will give instructions on which numbered tools are to be used to create the design.

Stamping tools are designed to obtain specific effects in the development of the design. Design is very important in this unit. Always plan a design which follows the lines of the article.

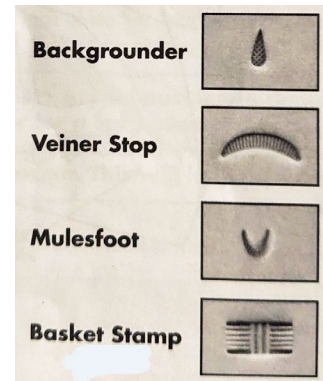

How to Create a Stamping Design

A stamping design can be simple or very complex. With the tools described previously, you can create many different basic designs. There are several guidelines to follow.

The design must fit into the shape of the article that you want to make. A long narrow design for a belt will not fit the shape of a wallet.

Start with a simple design, practice and experiment using the tools on a scrap piece of leather. Do not work on your final piece of leather until you have figured out and practiced everything that is necessary to create your project. Make all the mistakes, changes in tools or how you hold them on scraps first. A stamp or a tool makes a permanent mark on leather that cannot be erased. With a lot of experience mistakes can be modified, but not easily.

Look at many designs before you decide what you want to do. Then look closely at how the tool impressions are placed. Are they in a straight line? Do the edges just touch? Where exactly is one tool placed next to, over or below another? If the same tool or set of tools are used, they must be placed the same throughout each repetition to create the design. Practice this until you can do it correctly.

On a practice piece, draw guidelines with a ruler and a stylus so you can keep the placement of the tools in a straight line or to maintain the balance of the design on two sides or all sides depending how complicated a design you use.

Mark the Leather

Mark and practice your design on a piece of scrap leather so you can double check the size of the stamps and how they will combine into the final design. This is especially important in stamping geometric designs. Make all markings on the surface of the leather. You can make

lines heavy and have them as part of the design, or as light as possible so they will not show on the finished article.

A straight edge or wing dividers should be used to mark the center line. Keep dividers at a low angle to the leather and use very little pressure.

Make border lines the same way. These lines usually should be heavier than the center line.

A ruler or wing divider should also be used to mark spacing at the border and on the center line. Mark the spacing on only one guideline at this time.

Set wing dividers for the desired measurement and walk down the line.

Layout dots should be squared across to the opposite border or center line after the first layout line has been tooled. This will make them symmetrical.

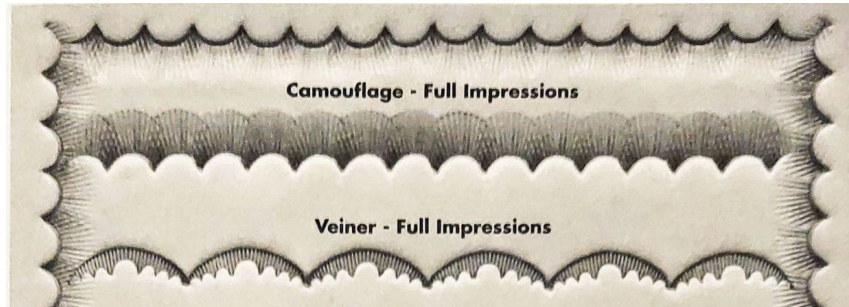
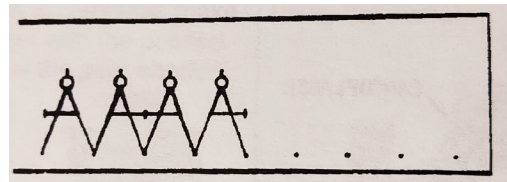
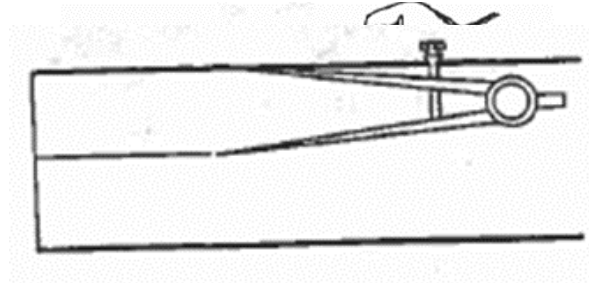

For the final piece, make the guidelines very lightly. Cover these lines as much as possible with tool impressions. They should not be visible on a finished article.

Make sure that there is enough space to fit the entire tool impressions needed for the article you make. For example, for a border design using a veiner, measure the distance available exactly. Use a practice piece which has a drawn guideline the same distance in inches. Count how many repetitions of the veiner are needed to fill this distance. Do whole impressions fit or is there only room for a part of one? If there is left over space that cannot be filled, make the length of the design shorter or alternate with another stamp to create a design that will fit in the distance needed. Carefully plot out how to do corners so they blend in and connect the straight lines. If you are doing a rectangular design, make sure that the number of impressions on the top line is equal to the bottom line. Do the same for the two sides. Remember to have space for the corners to fit. For an article that is laced or stitched, the pattern should be inset back from the edge so that the lacing will not cover the design when finished.

There are many patterns available for stamping designs on different sizes and shapes of leather articles. Project kits often include designs that can be used for that article. You can use a design provided in a kit, change it a little, or create your own design.

Chapter 3—Using Creative Stamping Tools

Basic Beginner Stamping Tools

The Mallet

The mallet is used to strike the top of a stamping tool to obtain its impression in the leather. A leather mallet should be rawhide or wood. **NEVER strike the top of the stamping tools with metal hammers.** This will damage your tools.

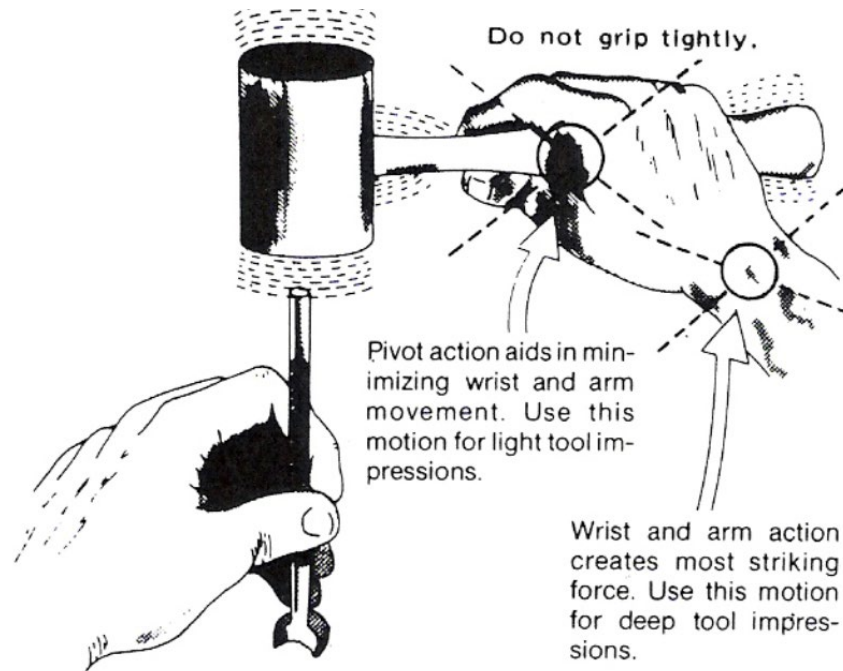

1. The mallet should be held in the most comfortable position for you, don't grip it too tightly. Hold the mallet in the center of the handle with your fingers rather than the palm of your hand.
2. Hold the mallet in the most comfortable position for you!
3. For deeper impressions, use the wrist as the pivot point. Hold the handle more tightly toward the end.

Stamping Surface

To stamp leather, it must be placed on a hard, smooth surface. The **best working surface** is a piece of marble at least $\frac{3}{4}$ inch thick. It will stay smooth as glass for years. A tempered Masonite board provides a good surface. **NEVER** tool leather on a bare table. Minor slips and mishaps will scar your tabletop forever.

How to Stamp Borders

These are just a few border design ideas. There are hundreds of possible combinations. Experiment!

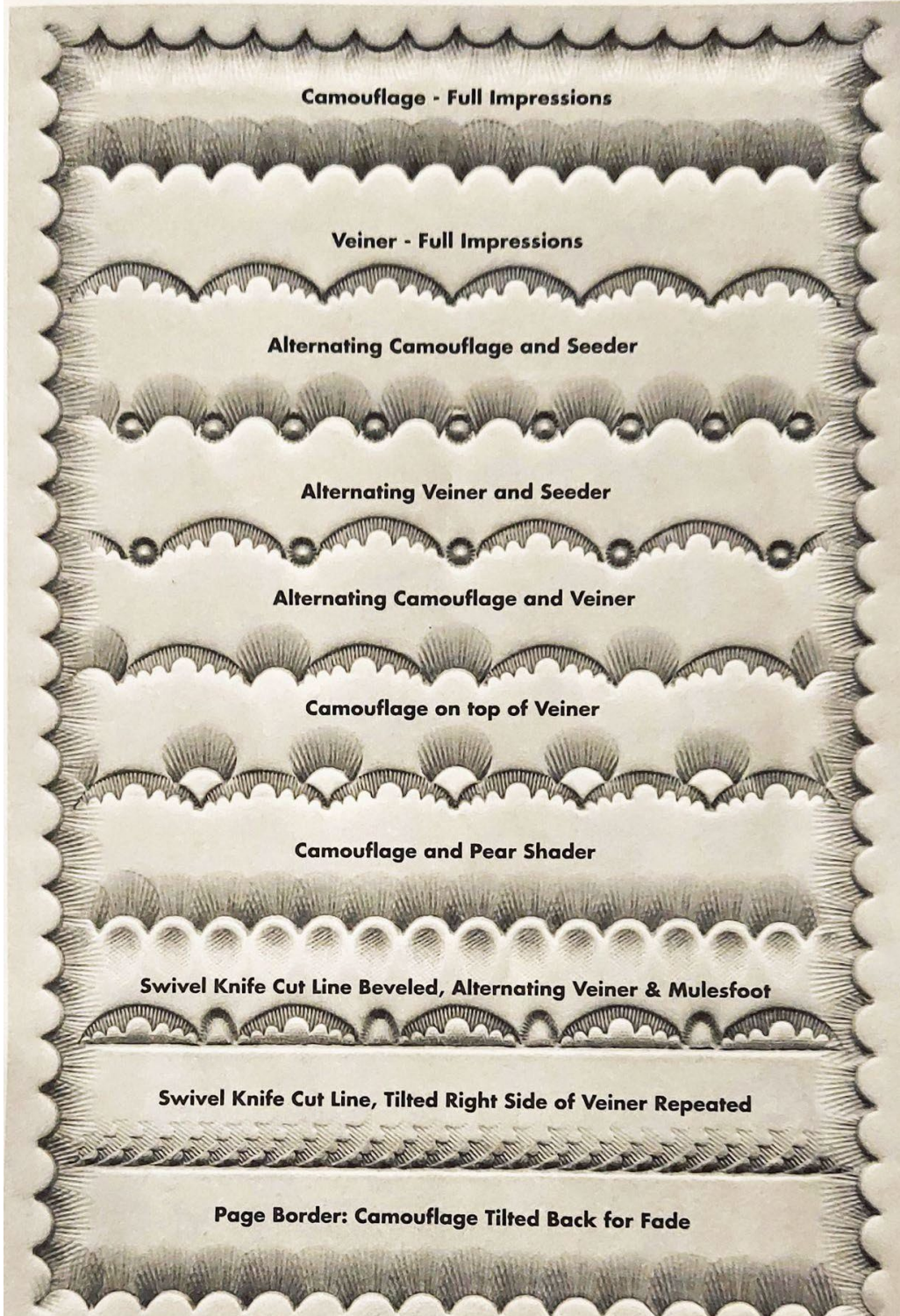

Stamping a Design

STAMPING A DESIGN

Here are a few fun designs using these basic tools:

Camouflage, Pear Shader, Beveler,
Veiner, Seeder, Backgrounder,
& Swivel Knife



THE END

Stamping Basket Weave

Hold tool straight up and down. Strike firmly for best impressions.

Border lines can be cut with a Swivel Knife and beveled or left uncut and used only as guidelines for border stamps. Scribe a center guideline using a Stylus.

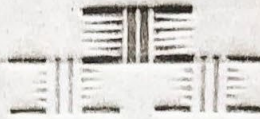

GUIDELINE

Stamp first impression in center on top of guideline. Stamp second and third impressions below guideline overlapping first impression, as shown above.

BASKET STAMPS COME IN MANY DIFFERENT SIZES AND SHAPES.

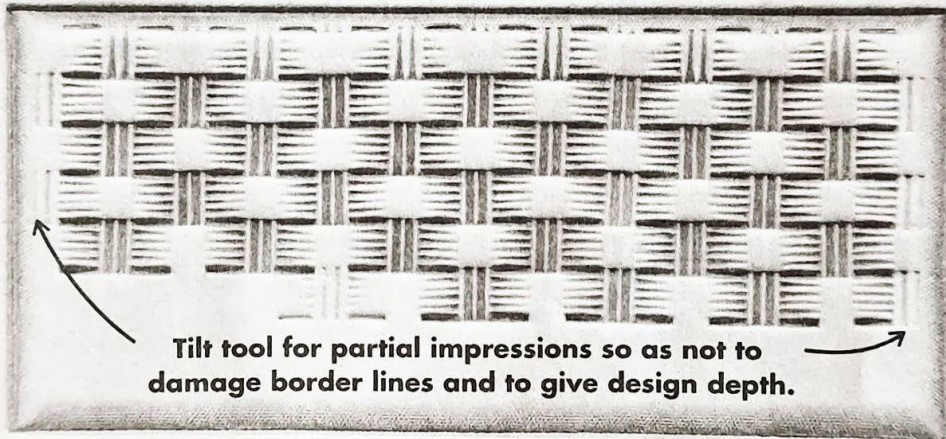

Tilt tool for partial impressions so as not to damage border lines and to give design depth.

ADD A BORDER USING THE CAMOUFLAGE STAMP

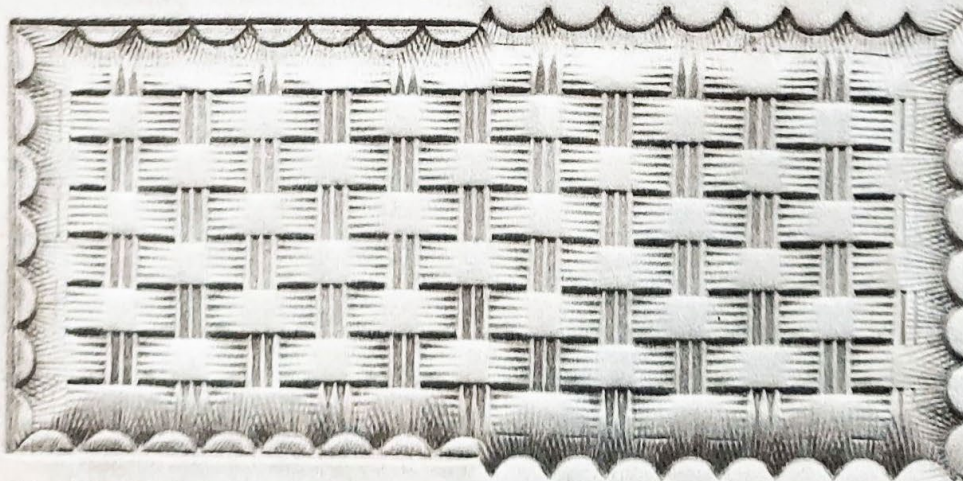

CUT, BEVELED & STAMPED BORDER

UNCUT STAMPED BORDER

3D Stamping Tools

Creative Stamping and 3-D Stamps



The supplies that are helpful to create a stamping design!

- Water spray bottle
- Polymer Mallet
- Wing dividers
- Ruler
- 3D Stamps and handles
- Letter Stamps
- Stamping tools
- Tracing tool
- Marble slab

Handle fits into stamp



Handle fits over stamp



Most 3-D Stamps come with a handle. The set of stamps and one handle that fits on to the top of the stamp. Some handles fit into the hole in the stamp and some handles fit over the stamp.

There are many kinds of stamps & tools available to stamp a design on leather. One kind of stamp is a 3-D STAMP. Most 3-D stamps are larger in size than the stamps you would use to tool a realistic flower, animal, or scene. 3-D stamps are 3 Dimensional and when stamped into the leather the stamp makes a realistic looking impression. There are many alphabet stamp sets available, some are 3-D and some are a stamp of the outline of the letters.

Using 3-D Stamps Stamping



When using 3-D stamps and large stamping tools there are several extra details to pay attention to!



Because of the larger size of 3-D tools you have to hold the tool

down very tightly. The tool likes to jump a little each time you hit it. You can see the shadow on the horse head on the left. Try to hit it only once. Most young people have a hard time hitting hard enough. A good way for the tool to make a better impression in the leather is for an adult to help hold the bottom of the tool down (like in the picture above) while the young person holds the tool and hits it several times.

There are also machines that the stamp will fit into, where the machine will press the stamp down. Using a heavy mallet will help too.



Scribe a light line to keep the letters lined up.



Be Creative with your tools, experiment on some scrap leather first. For the best Results, plan out your design and practice it on scrap first!

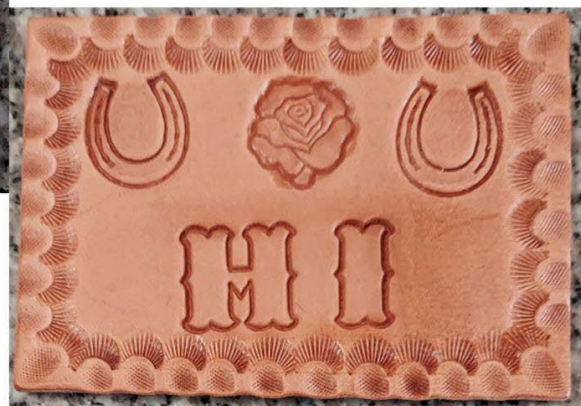

Chapter 4—Traditional Floral Carving and Tooling

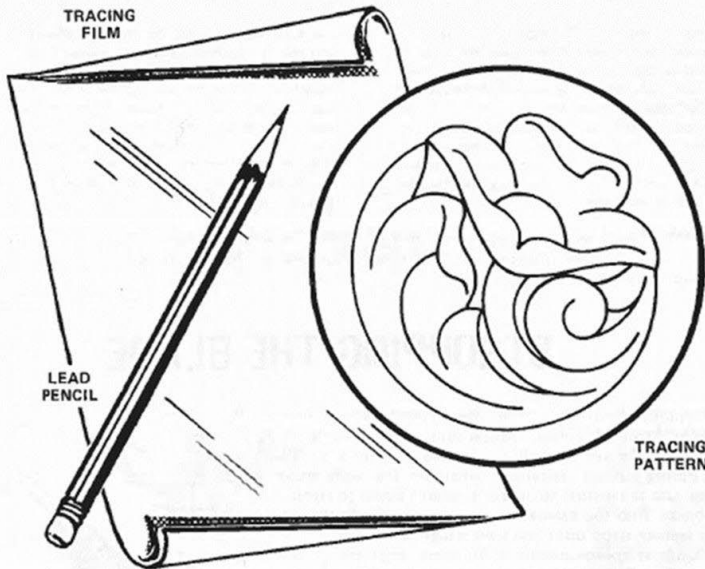

The Tracing Pattern

A tracing pattern is a drawing of the outline of a design, including the lines to be cut with the swivel knife. Even when the design is an original creation, a tracing pattern is necessary.

Decorative details or uses of the stamping tools are usually not shown on the tracing pattern.

Materials Required for Making Tracing Patterns:

Find or draw a **design pattern** you would like to use.

Tracing film is recommended for transferring tracing patterns onto leather.

Most tracing film is clear and has a waterproof surface that can be drawn on with a **pencil**. Draw on one side, the other side will be next to the damp leather when transferring your design.

Some tracing film has a glossy side and a side that can be written on. The glossy side will be next to the leather and pencil marks can be made on the non-glossy side. Some tracing film can be marked on both sides. Be careful to **make note which side has pencil marks** on it so pencil marks won't get on the leather.

Tracing film can be used several times and will outlast a tracing paper.

Never use carbon paper or ink pen to mark on leather, the marks are very hard to remove.

How To Make A Tracing Pattern

Place a piece of tracing film (glossy side down) or tracing paper over the tracing pattern and **tape or clip** it in position.

With a pencil, carefully trace over all the lines of the tracing pattern design (just as they are shown on the pattern).

Draw the flower first, then fill in with the stems and leaves. Erase incorrect lines and redraw them, if necessary. (Always have a good **eraser** on hand.) This is the time to correct any mistakes before the design is transferred onto the leather.

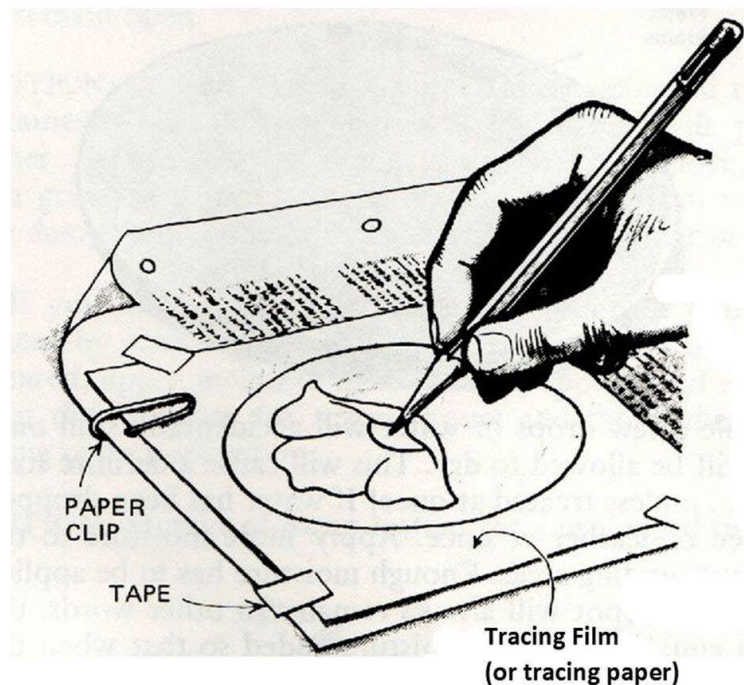

Transferring Your Design on to the Leather

Carefully place Tracing Pattern (pencil marks up) over the cased leather and tape in position. With a Ball-Point Stylus (or any dull-pointed instrument) retrace all the lines of the design....beginning again with the flowers, then with the stems and leaves. Press firmly, but not too hard and the lines will be transferred beautifully to the leather. Before removing tape, lift one corner of the pattern and check to see if you have traced all the lines.

THE MODELING TOOL & STYLUS

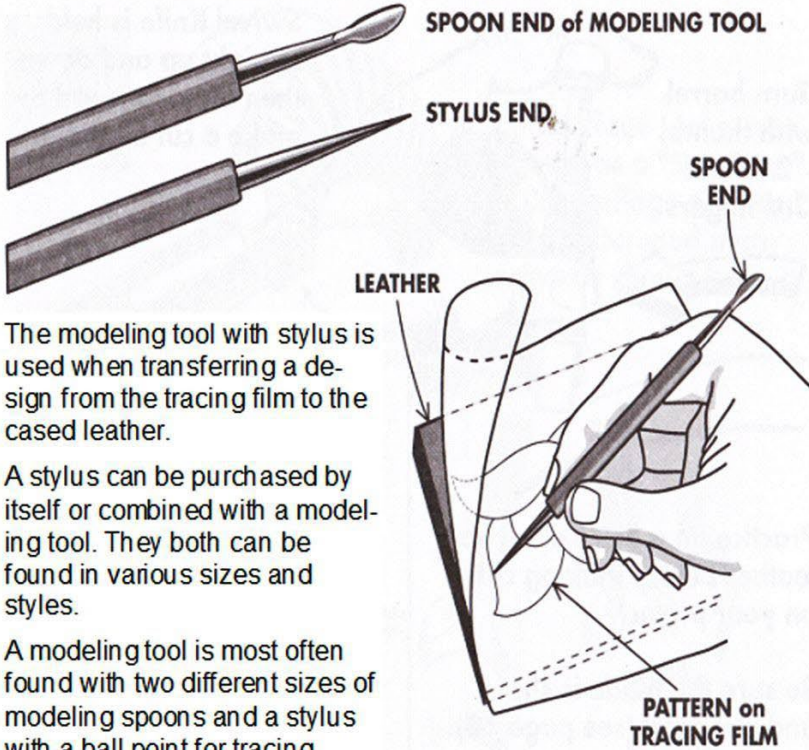

The modeling tool with stylus is used when transferring a design from the tracing film to the cased leather.

A stylus can be purchased by itself or combined with a modeling tool. They both can be found in various sizes and styles.

A modeling tool is most often found with two different sizes of modeling spoons and a stylus with a ball point for tracing.

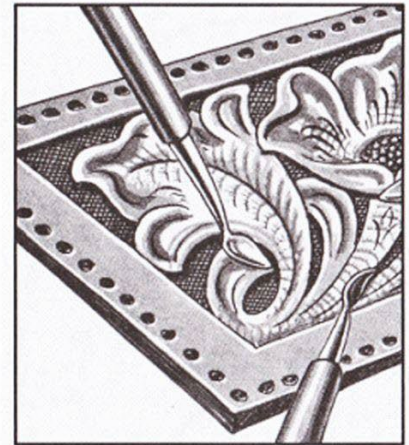

The spoon end of the modeling tool can also be used later during carving and shading process to smooth edges. The stylus can also be used in the lacing process.

Below are three tracing patterns to practice tracing.

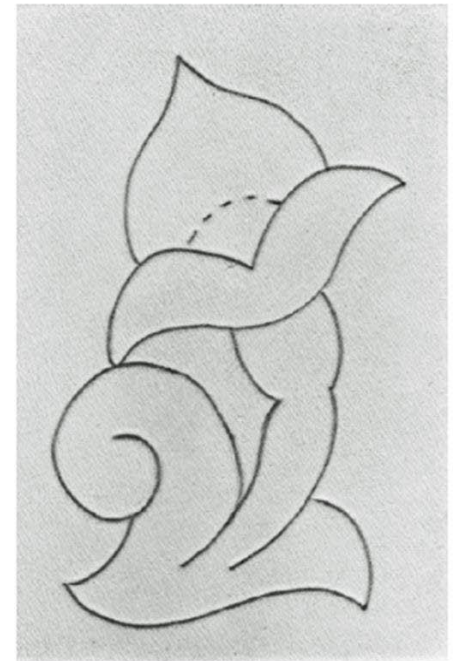
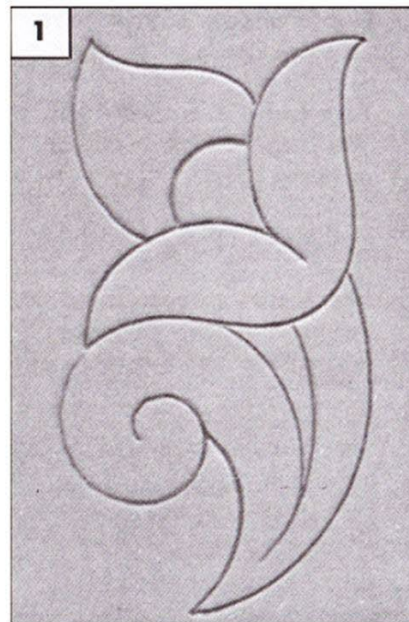
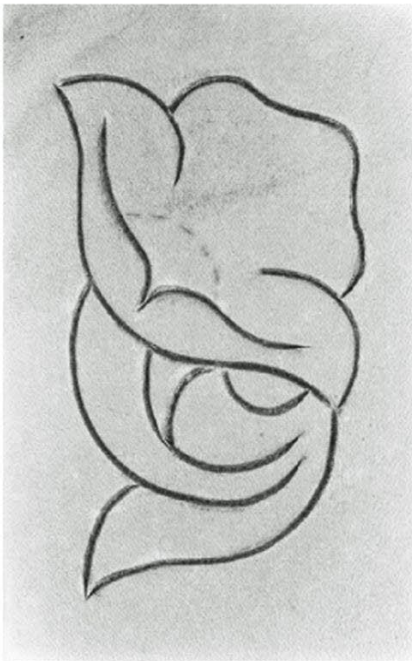

SWIVEL KNIFE

The swivel knife is the most important of all the leather carving tools. It is made so you can work efficiently in cutting very intricate designs.

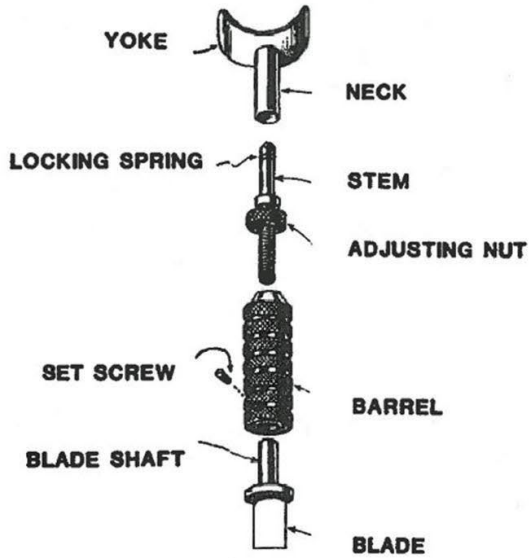

Find these parts on the diagram of the swivel knife.

Yoke – provides a rest and pressure point for the index finger. This helps control the depth of the cuts.

Locking spring – supplies tension on the neck, holding it in place when pushed into position on the stem.

Adjusting nut – varies the length of the blade to fit different hands.

Blade shaft – inserts into the barrel and is held in place by the set screw.

The blade, barrel and stem unit turns independently of the neck and yoke.

STROPPING THE BLADE

The beveled cutting sides of regular swivel knife blades should be stropped often during the cutting operations. Stropping the blade polishes the sides and keeps the blade cutting smoothly.

The swivel knife blade is the key to all successful leather carving. The Primary purpose of the blade is to cut the outlines of a design or pattern into the leather. Lines are cut to give depth to the design. With properly cased leather, the cuts should stand open so the stamping tools can be used easily.

Use a rouge board or the smooth side of a leather strap rubbed with jeweler's rouge to strop your blade. Insert the blade shaft into the barrel of the swivel knife and tighten the set screw with a small screw driver. Grasp the knife with the yoke pressed firmly against the palm of your hand.

Place the knife on the rouge board or strap at approximately a 30° angle. The beveled side of the blade must be flat against the polishing surface.

Hold the knife firmly in your hand and
PULL IN ONE DIRECTION ONLY.

Always PULL the blade across the polisher.
Turn the blade over to strop the other side.
Strop your blade often on the polisher as you work.

CAUTION: Never push the blade when stropping;
this destroys the fine cutting edge.

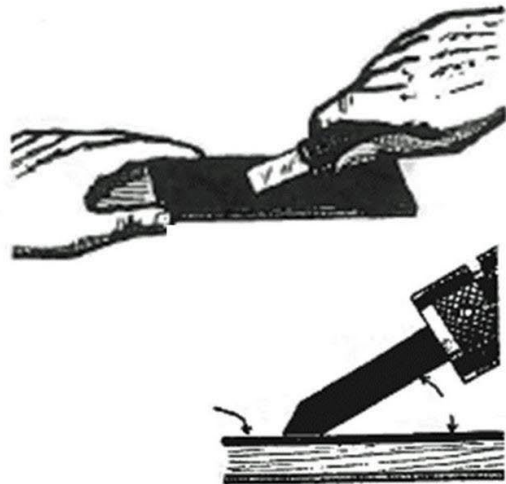

How to Hold the Swivel Knife

Learn to hold your swivel knife correctly. The way you hold the swivel knife will determine your success in cutting leather. Follow these simple steps below for aid in learning how to hold the swivel knife properly.

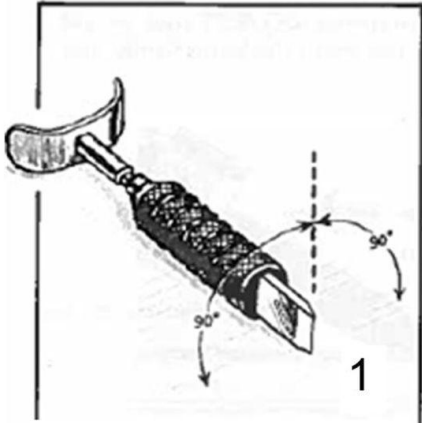

1 Place the knife on your bench as shown...with the length of the blade straight up and down, at 90 degree angle to the bench.

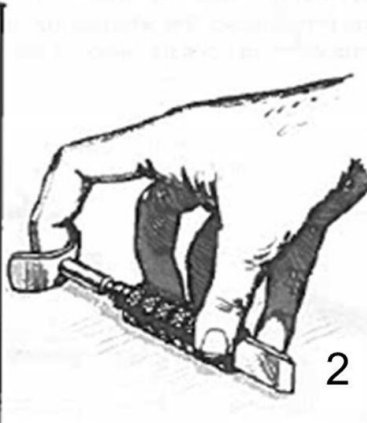

2 Place fingers as shown. Index finger in yoke; thumb at lower part of barrel; little finger against the blade; and 2nd and 3rd fingers on opposite side of barrel.

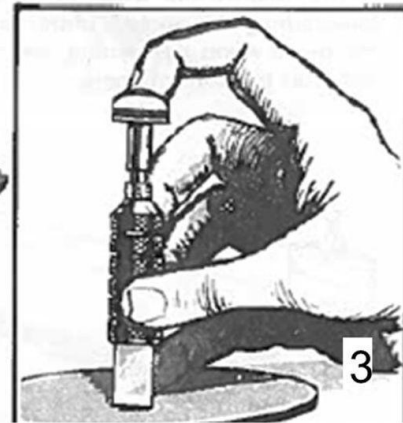

3 Pick up knife; hold in upright position and rest hand on bench and blade on practice leather, as shown. CAUTION: DO NOT set blade on metal, or any hard or abrasive surface that might damage the cutting edge.

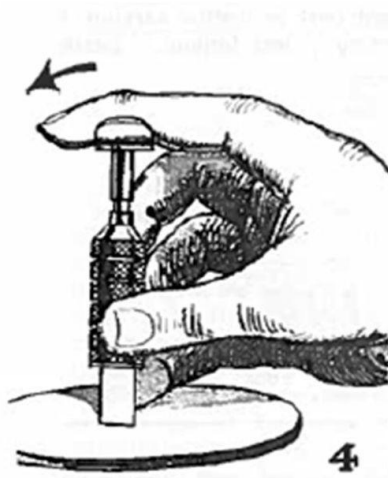

4 Since the knife is merely held in the tips of the fingers, it is obviously not in position to be used. Move index finger forward and rest on yoke at first joint of finger, as shown.

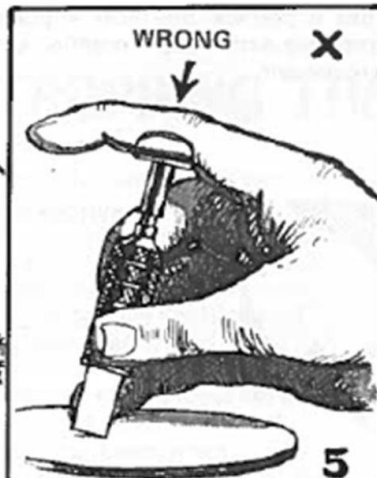

5 **WRONG:** Do not allow yoke to rest at 2nd joint of finger as most control of index finger will be lost.

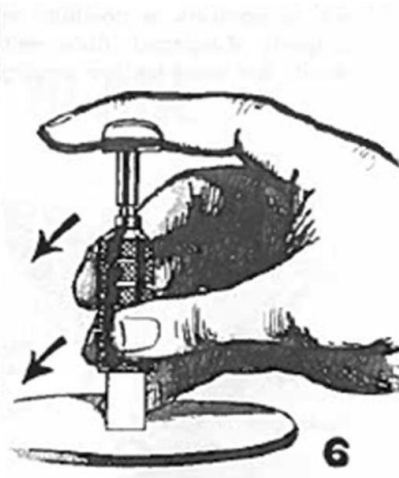

6 Move 2nd and 3rd fingers forward to more firmly grasp the barrel. Knife is now in correct position for use.

If the leather is cased properly and the blade is sharpened correctly it will glide smoothly and easily. If the blade does not pull easily, the leather may be too dry, or the blade may not be polished well and/or not sharpened enough. Examine the leather and the blade. Remember, leather must be moist for proper, easy cutting; the blade must be sharp and polished well.

A swivel knife that rotates easily is preferred for easy cutting.

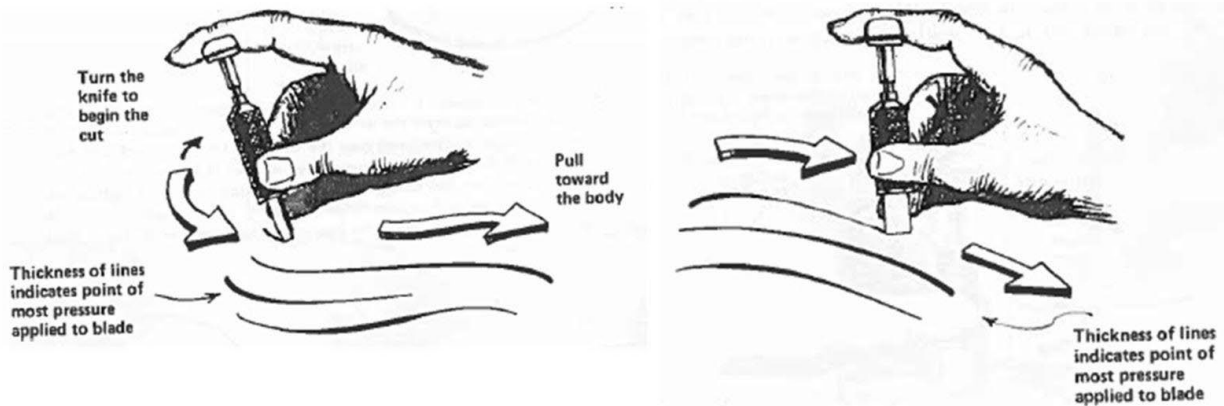

Undercutting

Undercutting is caused by leaning the hand to the left or to the right while cutting. This usually happens when you try to get a better look at what you are doing and tip the knife. The blade may "cut under" the surface of the leather on one side of the cut, leaving a thin, raised, undesirable edge.

WHAT CAUSES UNDERCUTTING

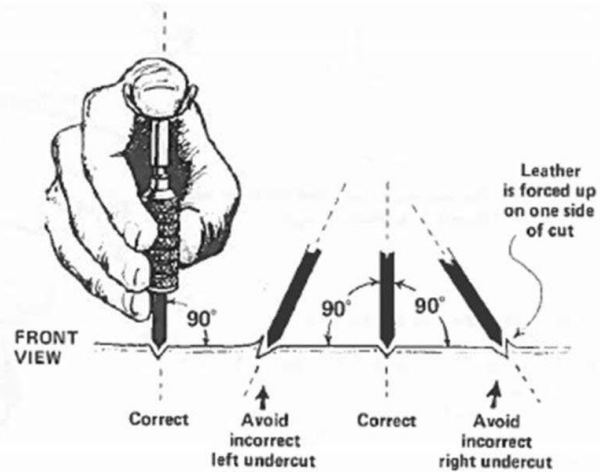

Cutting curves

The next diagram shows the proper position of the knife blade while going around curves. Only the cutting part of the blade is shown. The flat of the blade always parallels the cut. The blade is tipped forward to obtain the correct cutting angle, but never leaned to the right or the left. It must always remain perpendicular to avoid undercutting.

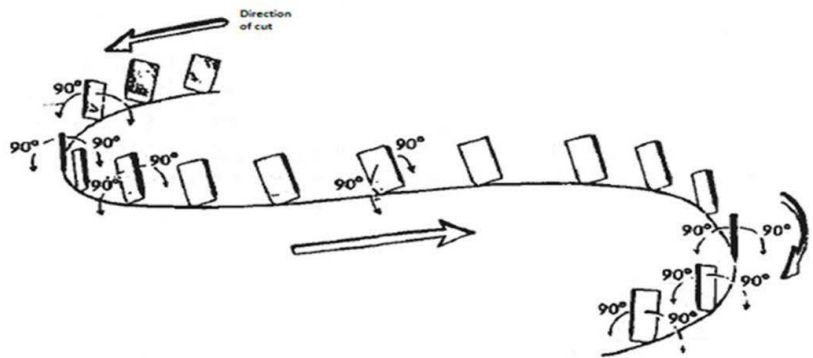

CUTTING CIRCLES

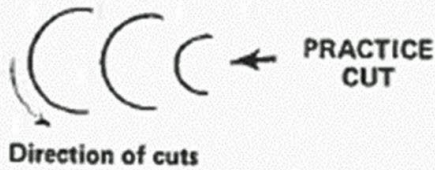

Starting position for cutting the left side of a circle.



Cutting Circles

To make circular cuts, turn the barrel of the swivel knife with thumb and fingers. Hold knife in the regular position with blade parallel to the arm; pointing toward your body. Now turn the barrel clockwise until the blade is at right angles to your body. Use the starting position shown below for cutting the left side of a circle.

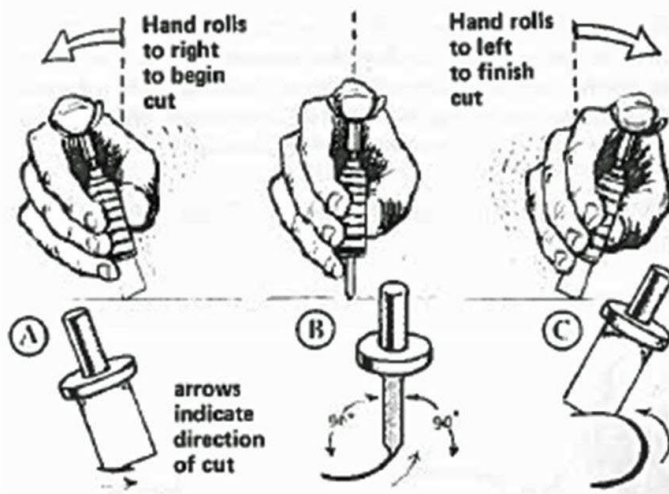

FRONT VIEW: showing position of hand and blade for cutting the left side of a circle.

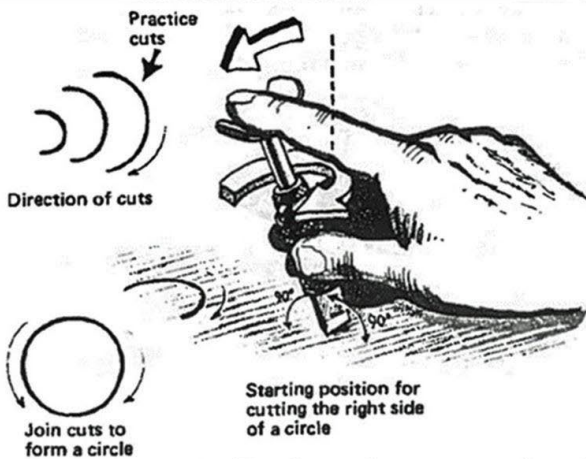

Slightly roll your hand to the right until the blade is tipped forward to the proper cutting position.

As the circle continues, your hand must begin rolling slightly to the left to keep the point of the blade in an upright cutting position. When the half-circle is completed, your hand should be in the position as shown.

Cutting and rolling movements are made simultaneously. A great deal of practice will be required to coordinate these movements.

Practice cutting different half-circle sizes. Once you have learned the skills, this will be easy.

To cut the right side of a circle, reverse the steps shown. Start with a left-hand roll and end with the hand rolling to the right.

Even though you may prefer cutting or turning the knife in one direction, it is important to practice cutting in all directions.

Try some of the practice exercises.

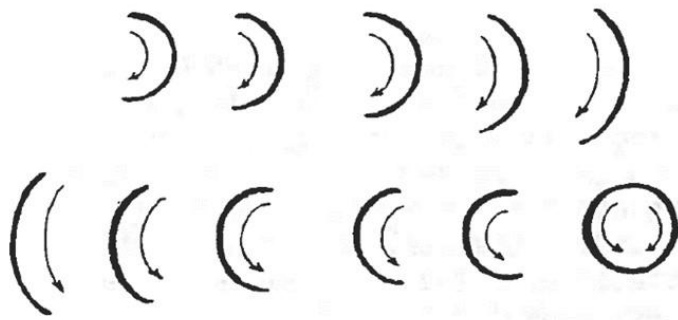

Cutting Circles

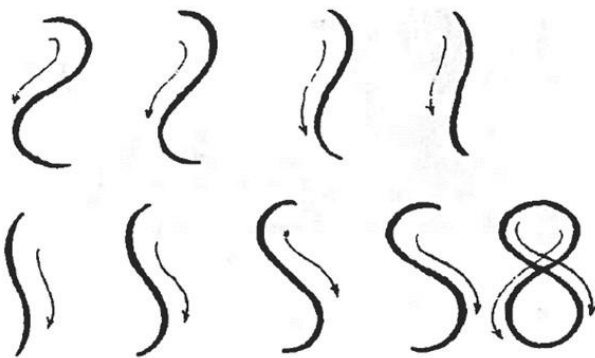

Cutting Figure Eights

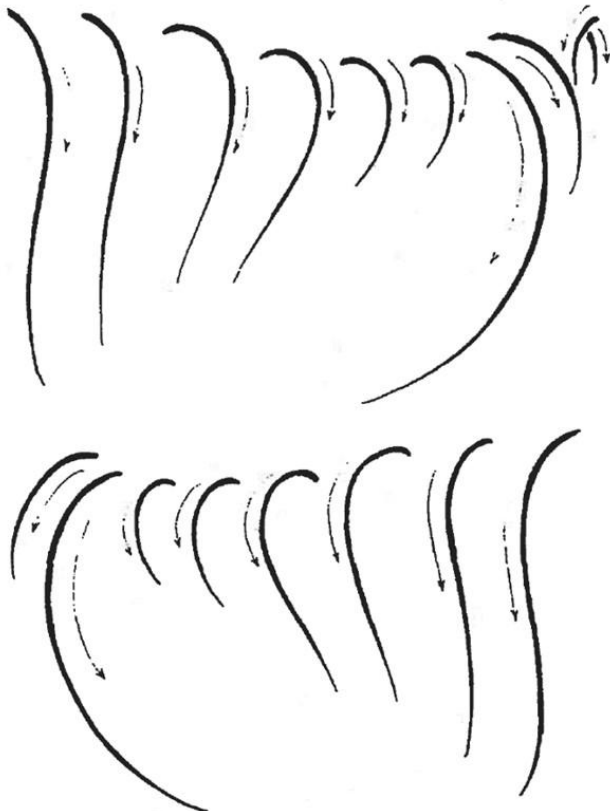

Cutting Flowing Lines

Make cuts with one, long flowing motion.

Turn leather when necessary to aid in smooth cutting.

How to Cut the Design

- *In most cases, the flower is cut first. Then cut the leaf and stems.
- *Make all cuts toward the body as much as possible.
- *Turn the leather whenever necessary to keep the hand from becoming cramped or strained.
- *When cutting the first design, do not be overly concerned if you stray from the lines.
- *Do not try to re-cut any of the lines.
- *Practice cutting with a flowing motion and soon the cuts will be easily controlled...the knife blade will go where you want it to go.
- *When necessary, turn the leather NOT your hand, so that your hand and knife will remain in correct position. With practice, you will acquire speed and control.
- *BE SURE YOUR BLADE IS SHARP! STROP IT OFTEN ON THE LEATHER STROP!
- *Practice until you can make your cuts quickly, evenly and with a minimum of effort.
- ***Always practice on a piece of scrap leather before starting on your final project!**

These patterns are good patterns to use for beginners! They are sized to fit on a 2 1/4 inch by 3 1/2 inch piece of leather.

1/2 of a wallet size is called a half back—this size 3 1/2 by 4 1/2 in.

This pattern is 1/2 of a half back.

(Many leather stores carry half backs.)

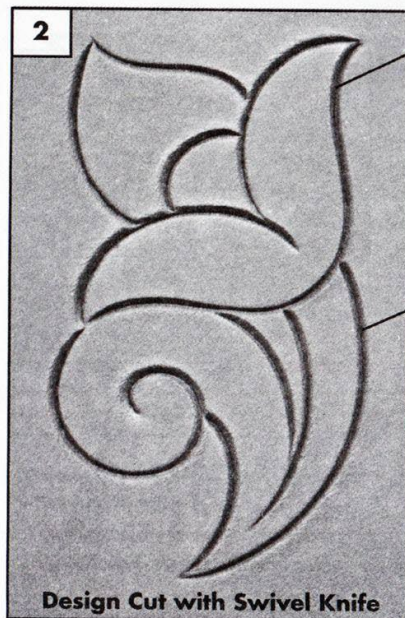
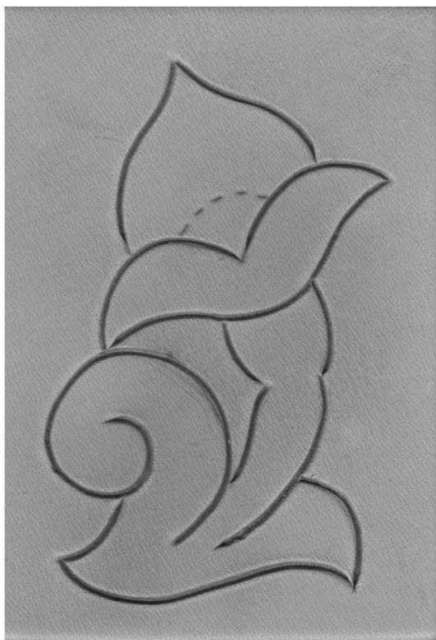

Depth of cuts needs to be 1/3 to 1/2 the thickness of the leather.

Make cuts smooth and deep. Practice-practice and & **practice some more!**

Some patterns have a dotted line around the seed pod and some have a solid line around the seed pod. Dotted lines are not usually cut with the swivel knife. They will be beveled without being cut, making it have a more natural looking seed pod. Sometimes when the seedpod is cut the line always shows. In most patterns dotted lines are not cut.

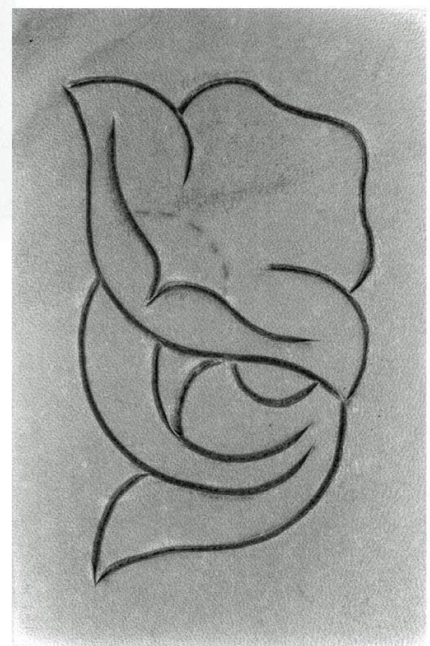

THE CAMOUFLAGE

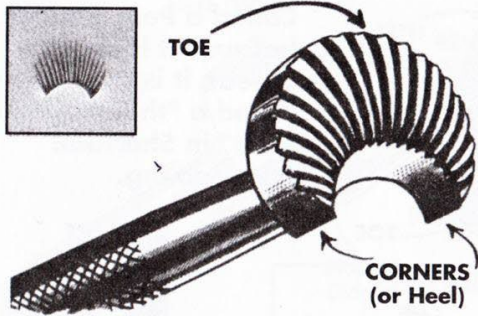

Camouflage tool is also known as a "Sun Burst".

A camouflage or "Cam" can be stamped many ways as shown below.



Camouflages are available in different shapes and sizes.

1. Hold the tool **straight up and down**, then strike sharply with the mallet so that all lines are equal in depth.

2. **Lean the tool to the left.** Hold securely with hand so tool does not slip when struck with the mallet. Impressions on the right side should "fade" to nothing.

3. **Leaning the tool to the right** fades the left corner impressions and firmly imprints the right corner of the tool. Hold tool firmly.

4. **Here the tool is tipped forward** on the toe so that the corners do not dig in. The tool is usually tapped lightly in this position.

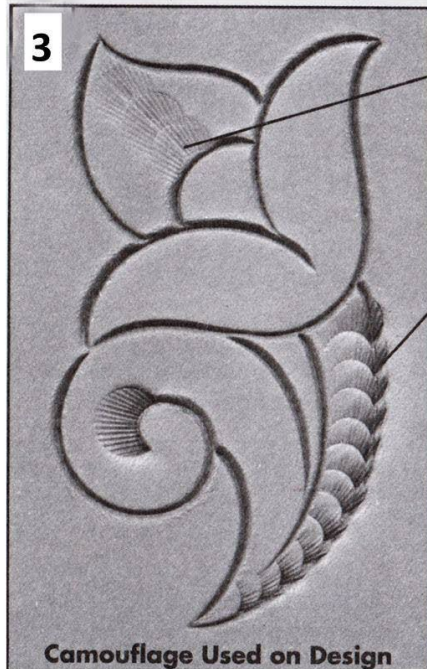
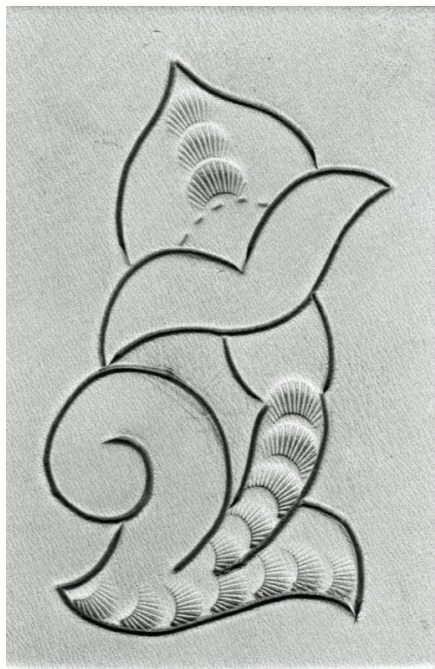
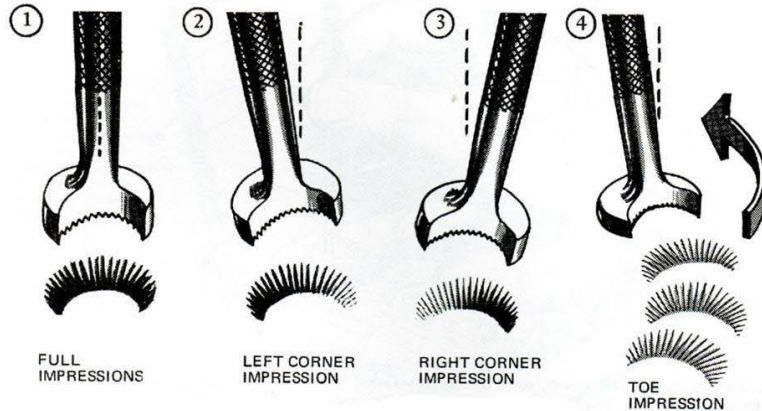

Camouflage Used on Design

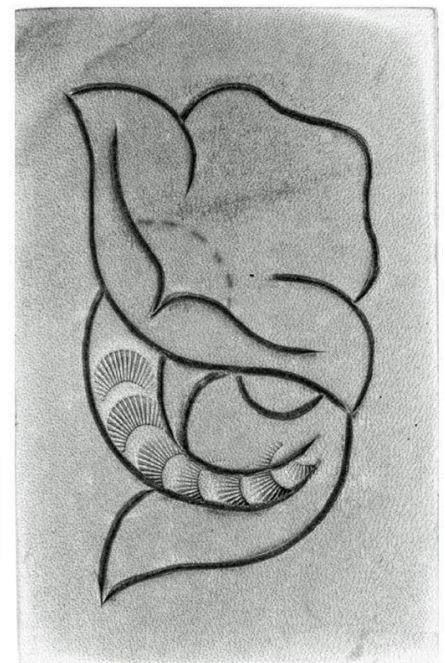

THE PEAR SHADER

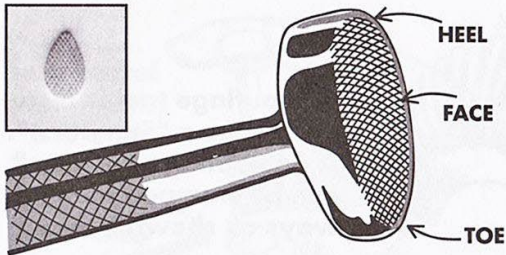

Called a Pear Shader because it looks like a pear, it is also called a "thumb print" in Sheridan Style tooling.

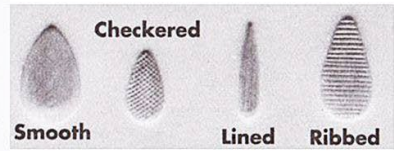

Pear Shaders are available in different styles & shapes.

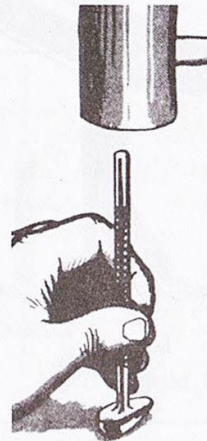
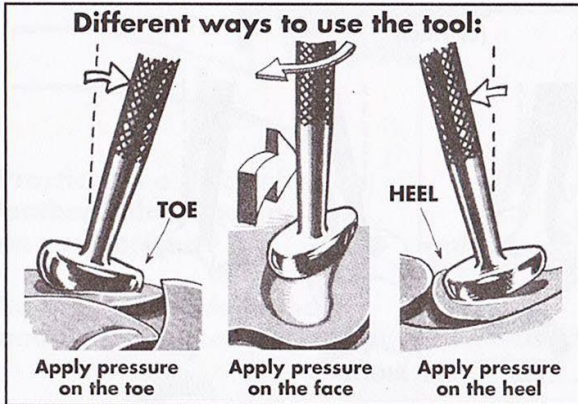

"WALKING THE TOOL"

A technique of striking the tool & moving it to overlap the previous impression, all in one continuous motion.

Used with the pear shader, beveler & backgrounder.

It takes practice to learn to shade smoothly. Start by developing a rhythm: move-hit, move-hit, move-hit, etc. This is called "walking" the pear shader. Uneven shading is caused by not moving the tool along the surface evenly between each stroke of the mallet.

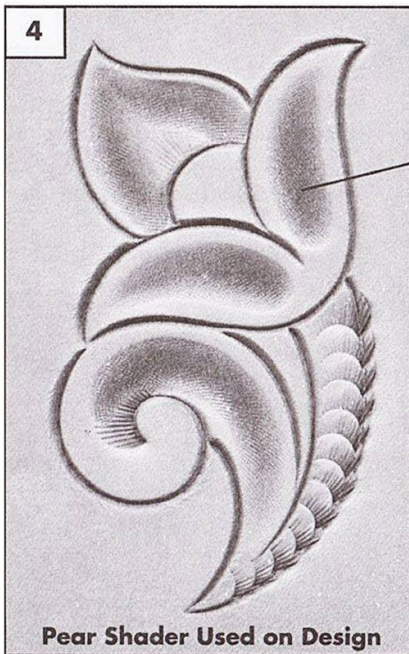

Pear Shader Used on Design

Move the pear shading tool along the surface of the leather in the direction shading is desired, using less force as the shading fades out. Keep your hand in a comfortable, relaxed position.

Heel is used in larger, open areas while toe is used in narrow spaces.

Areas stamped with a **pear shader** will burnish (darken) the leather, giving a design depth and dimension.

The "Walking the Tool" technique works well.

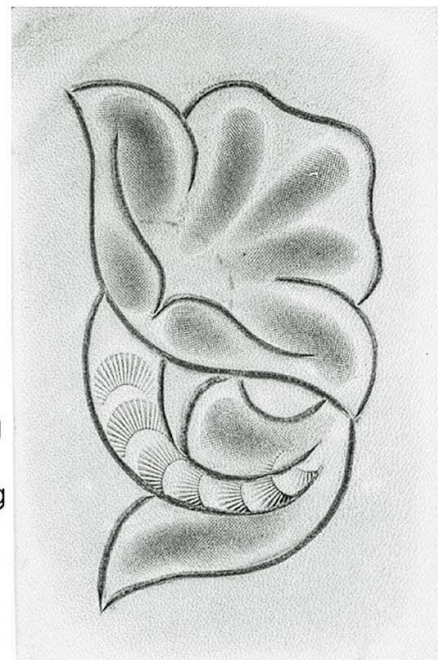
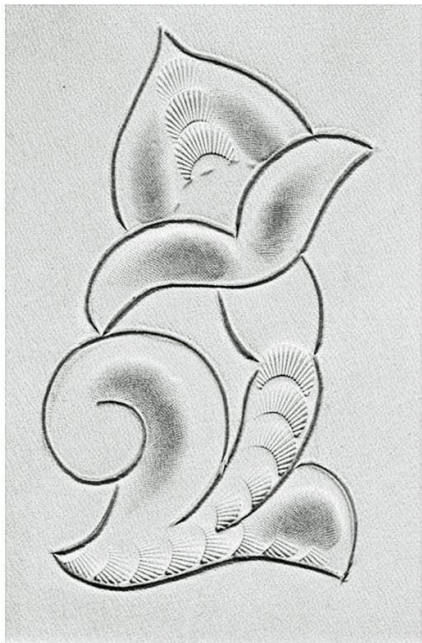

THE BEVELER

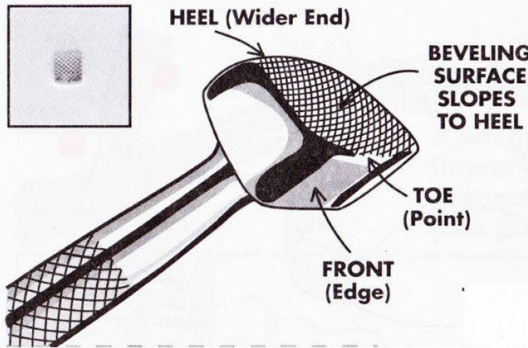

A Beveler is used to bring parts of the design forward or push parts back for depth. The Toe is normally used to make impressions.

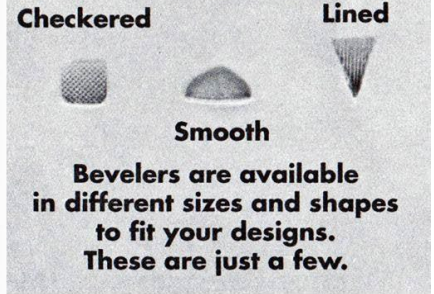

The face (front) of the beveler faces the cut line of the design.

Keep the face (front) of the beveler generally toward you. Turn the leather to keep the tool in this position.

The toe of the beveler is placed directly into the cut. The deepest part of the bevel is usually in the cut line of the design.

When the beveler is struck with the mallet the action compresses (darkens) the leather on one side of the cut, creating depth. This action at the same time burnishes (darkens) the leather and gives contrast to the design.

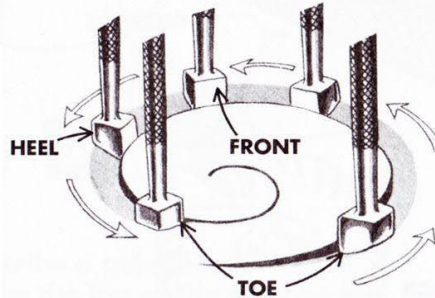

The purpose of the BEVELER is to bring the design into bold relief, creating a three-dimensional effect.

Hold the beveler straight up and down for the best results.

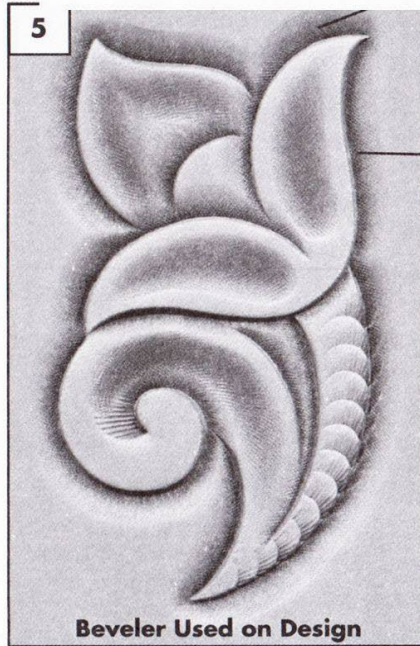

"Walk the Tool", striking it and overlapping the previous impression (1/2 to 2/3) for a smooth, even effect.

A Beveler's impressions create HIGHS & LOWS in the design.

You can bevel on either side of a line, depending on the effect you want.

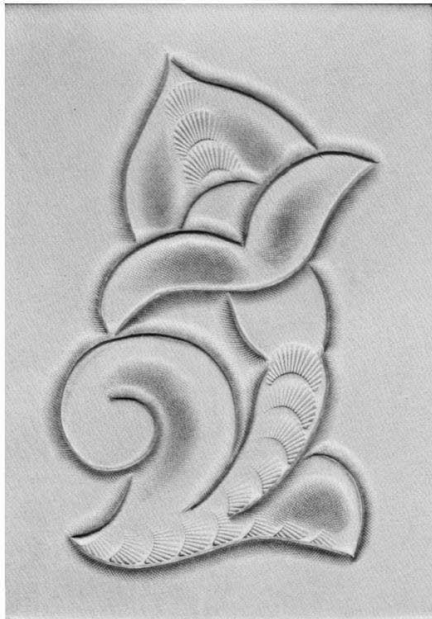

The moisture content of the leather should be "just right" (slightly on the dry side) for beveling.

It takes time to learn to bevel smoothly. Practice! Soon you will be beveling with ease!

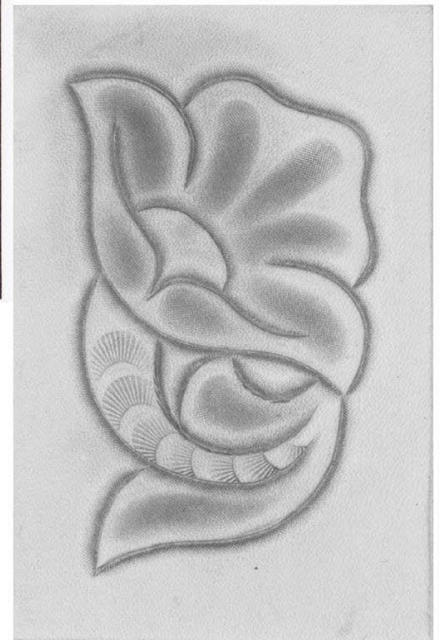

THE VEINER

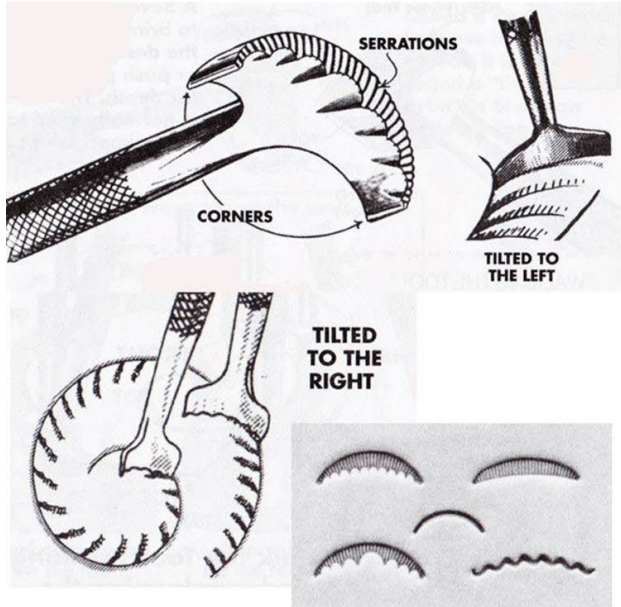

A **veiner** is primarily used tilted to the right or left to make vein impressions in flower leaves and scrolls.

The vein design is often used to create tightly rolled up fern leaves.

Applying different pressure on the tool will create depth and dimension in a design.

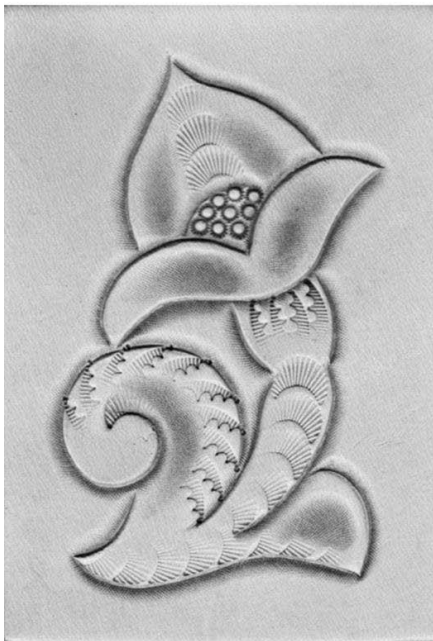

THE SEEDER

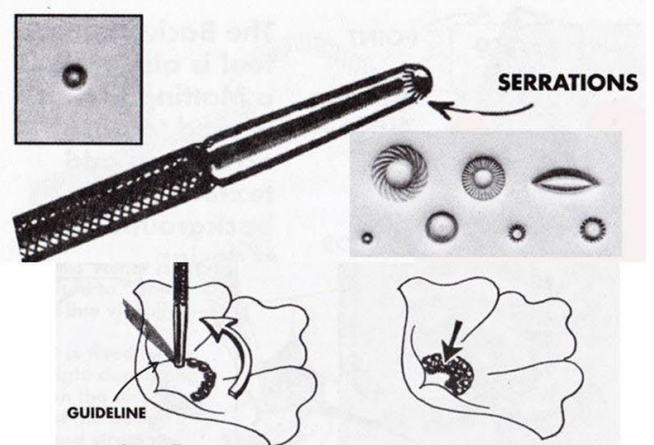

The **seeder** tool is used to make flower centers, seeds and decorative accents on designs.

To make a flower center, scribe a guideline to follow. Some people cut and bevel the line, some just bevel the line, decide what you like.

Start to use the tool across the top of the area on the guideline, then fill in the center with more impressions.

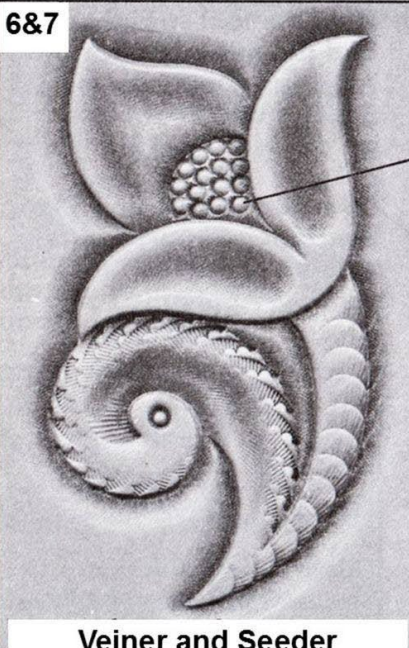

Veiner and Seeder are used on design.

There are many sizes and shapes of veiners and seeders available to fit your designs.

Normally a seeder is held straight up and down and struck firmly to create one whole impression. However, to give a design more depth, the seeder can be tilted to one side and struck firmly or lightly.

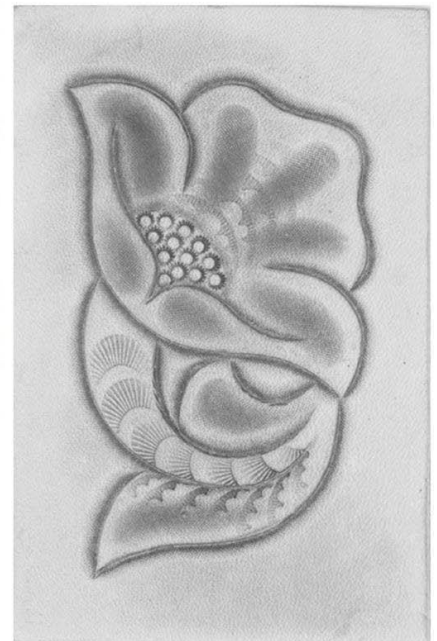

THE BACKGROUNDER

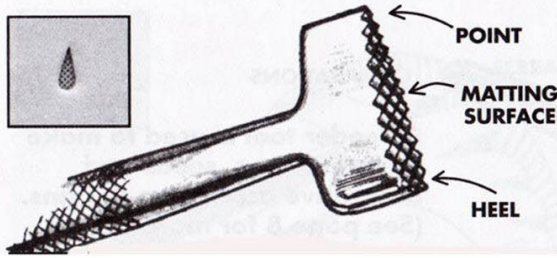
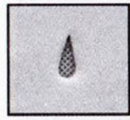

The Backgrounder tool is also called a Matting tool. It is used to push down and add texture to the background of a design.

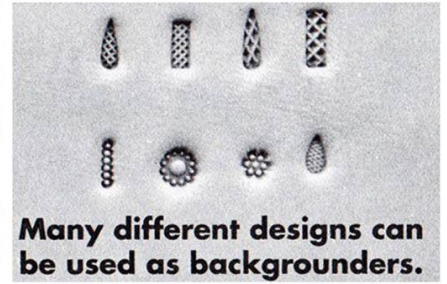

Many different designs can be used as backgrounders.

The purpose of the background tool is to matt down the background areas within and around the design.

Backgrounding is one of the most important steps in leatherwork because it makes your design "stand out" in bold relief.

Hold the tool straight up and down and strike it with uniform blows of your mallet.

Keep the overlapping impressions smooth and even— not choppy. "Walk the tool".

Apply the same pressure on each strike. Use a lighter pressure on each strike when smoothing up the background areas once they are matted.

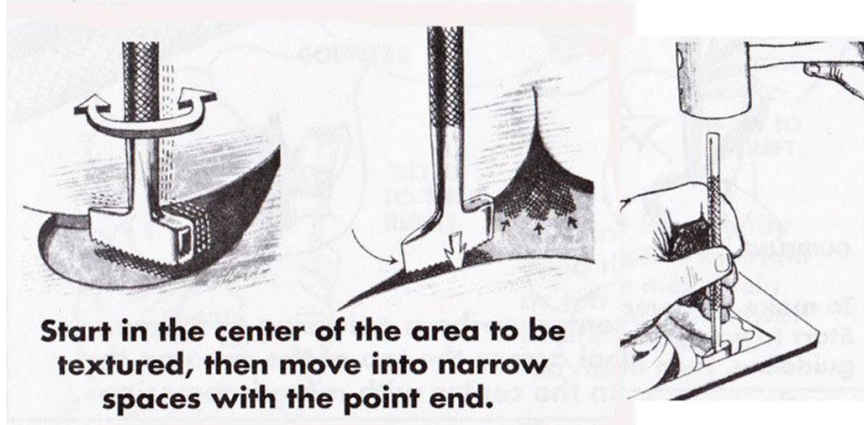

Start in the center of the area to be textured, then move into narrow spaces with the point end.

Carefully fit the tool into the area before striking it with the mallet. In very small areas, the tool can be leaned toward the point keeping the heel from touching a raised portion of the design.

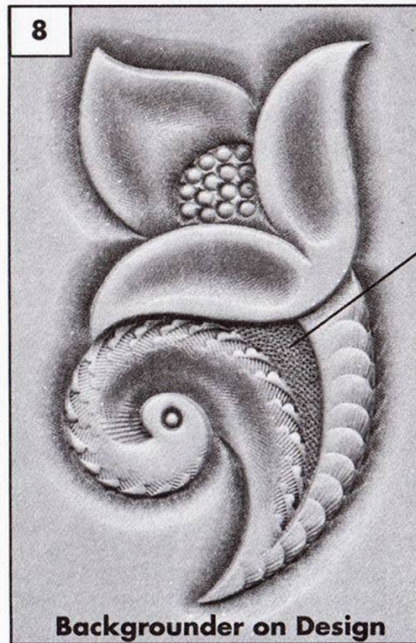
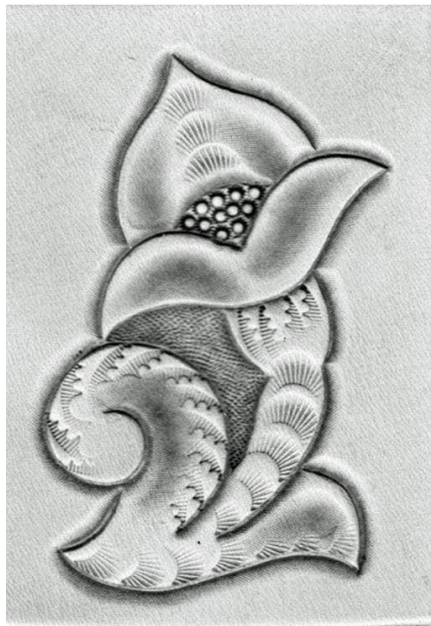

For best results, the moisture content of your leather should be "just right" (slightly on the dry side) when backgrounding.

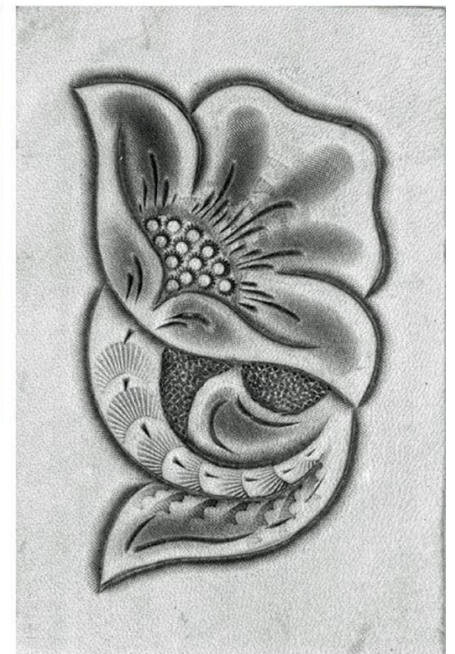

DECORATIVE CUTS

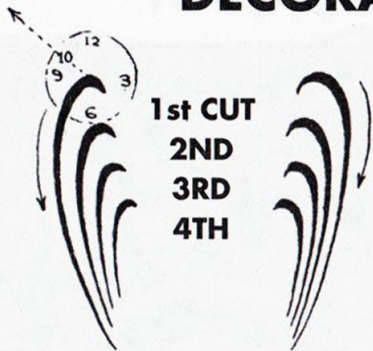

1st CUT
2ND
3RD
4TH

Decorative cuts made with a Swivel Knife add "the finishing touch" to a carved design.

Practice making curved cuts on a scrap piece of leather before making cuts on your project.

Decorative cuts are cuts you make to decorate or make your design more attractive.

Decorative cutting is done after all other carving and stamping has been completed.

It is normally the final step in adding ornamental detail to your design.

Plan your decorative cuts. They are meant to be accents to the design but can overpower it if too many are used.

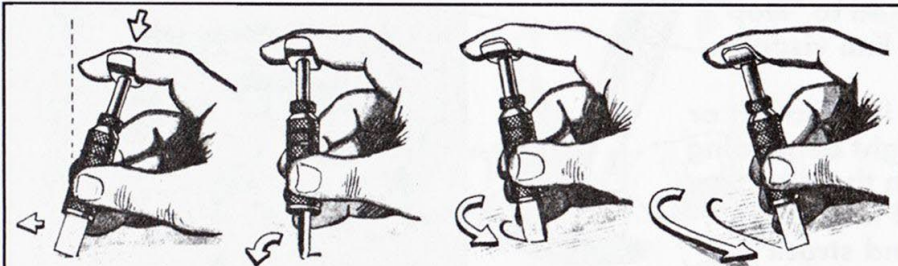

Apply pressure as the cut is started and makes the curve. Begin releasing pressure on long side of curve. Continue easing up on pressure until the end of the cut.

Different swivel knife blades are available. Choose the blade that works best for you.

Be sure to keep your blade sharp and stropped.

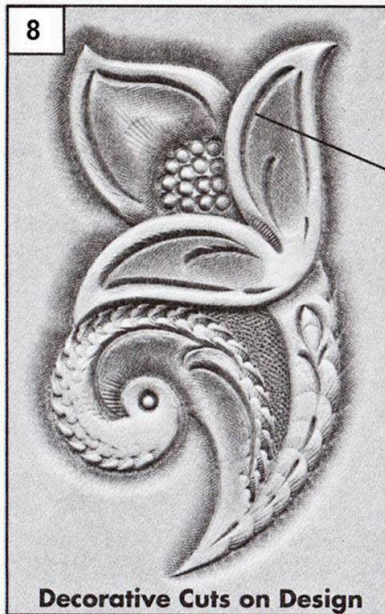

Decorative Cuts on Design

Proper moisture content is very important for good decorative cutting. It may be necessary to slightly dampen the grain surface of the leather to achieve correct results with decorative cuts.

PRACTICE—PRACTICE—PRACTICE!

Decorative cuts should follow the flow of the design.

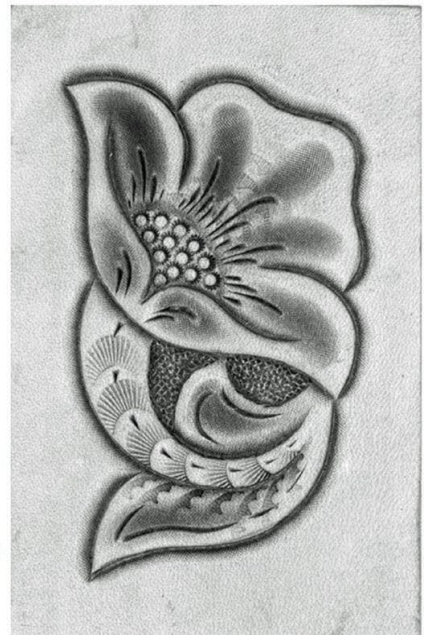

More patterns to practice are in the appendix.

Chapter 5—Carving Techniques and Styles

Carving designs to add decoration is a traditional method of leather working. There are many kinds of carving tools that are used to make lines, grooves, and patterns into the leather. Inverted leather carving can be classified into three groups that are described below. These groups are the inverted, silhouette, and rough-out techniques. Filigree work, figure carving, and pictorial carving are described. This chapter ends with a section on framing and mounting leather pictures.

Inverted Technique

Inverted carving differs from the regular raised carving in that the design itself is depressed (not raised). This is accomplished by beveling on the inside of the design outline instead of the outside. All other tooling within the design outline is done in the traditional manner.



Inverted carving usually takes less time to execute, as no background stamping is required. More delicate designing is possible in that thin stems and single cut lines can be used. Background areas remain raised and untouched – just in reverse of the usual beveling and stamping methods.

Inverted Carving



Case the leather, make the tracing pattern and transfer the design as usual. Keep the swivel knife blade sharp; strop it often for best results.

Cut the pattern with the swivel knife. Carefully follow the lines. Turn the leather when necessary for smooth flowing cuts.

Inverted Carving continued

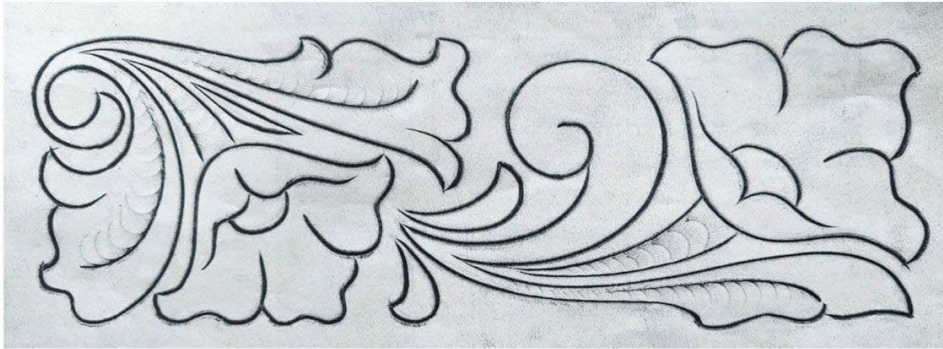

Use the **camouflage tool**. Space the tool impressions evenly.

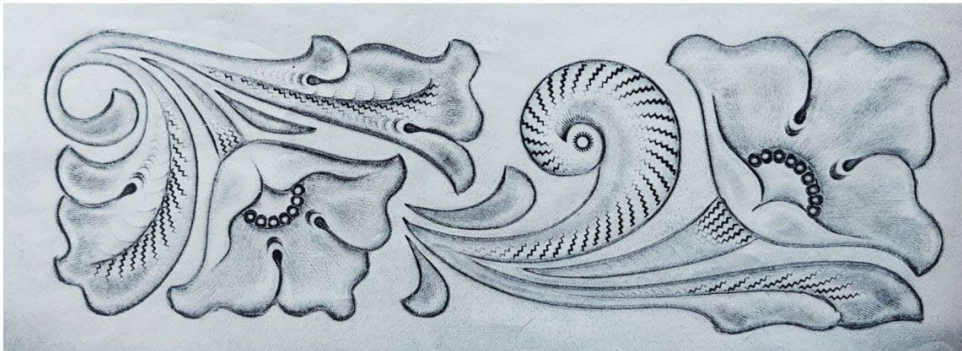

Bevel the design within the outlines. Pay particular attention to the pattern itself. As you will note, the beveling changes sides of the cuts in many instances....as within the design...flower petals, etc. Cuts are beveled as usual. Space the **Veiner impressions** evenly. **Pear Shaders** are used on inverted designs same as for regular carving. Use proper size tool for best results. "Walk" the tools smoothly to avoid choppy shading. **Use the seeder as usual.**



The "Stop" is used to accent the base of the flower petals and to end cuts at other parts of the design. The **Mulesfoot**, so named for its shape, is usually used in conjunction with the Stops. The impressions gradually diminish. To obtain this effect, simply lessen the force of the blows with the mallet.

The Decorative Cuts are the final step in completing the design. Good Decorative cutting comes only with a lot of patient practice...and complete relaxation. You should be comfortably seated at your bench. Turn the work as often as necessary to make smooth flowing cuts.

Silhouette Technique

SILHOUETTE STAMPING

Silhouette stamping is the easiest of all inverted carving techniques. Only the outlines of the design are cut. The bevelers are used within the outlines, and the design then matted down. No decorative stamping is used on the whole of the design. **The swivel knife becomes the most important tool, and control of it is of the utmost importance.** The lines of the design should be cut as accurately as possible for finest results and effects.

USING THE SWIVEL KNIFE

WRONG

Do not join cuts at point of paralleling intersecting lines (arrows) as these pointed slivers of leather may curl up and peel loose....even after matting.

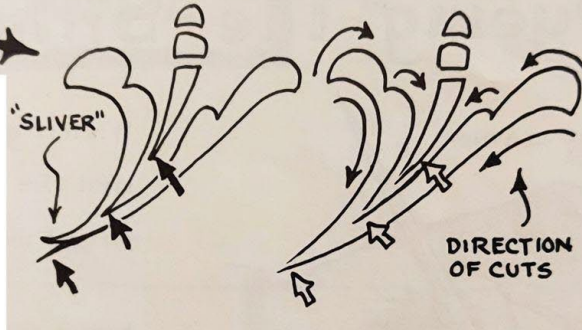

RIGHT

Lessen depth of cuts at point of intersecting lines (arrows) to avoid "slivers"...as in the wrong example at left. Do not completely join these cuts.

BEVEL THE DESIGN

Although the design is to be matted down....beveling is still recommended, as it brings more depth and cleaner edges to the pattern. Begin with largest tool and bevel all long-flowing lines, easily accessible. Use small bevelers for short lines and tight turns. Bevel inside the lines and use pointed bevelers where needed.



Cut all the lines of the design with the swivel knife.

Bevel carefully along converging lines of thin stems, etc., as heel of tool will smash down opposite wall of cut, destroying desired effects.

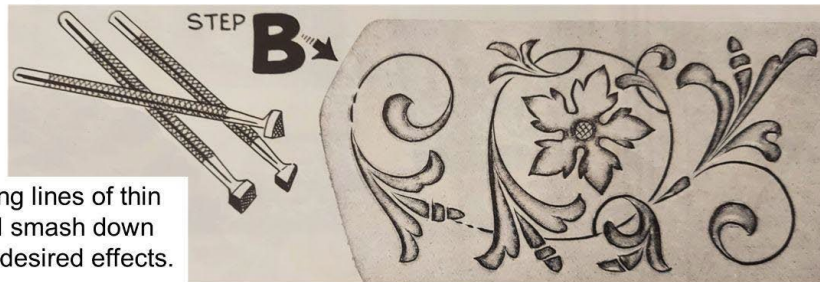

Begin matting in the fine pointed areas. Hold the matting tool in the straight up and down position. Use larger matting tools as the spaces get larger. Matt with uniform depth and evenness. Moisture content should be low when matting. Use modeling tool and stylus to smooth up edges where necessary for more clarity of design.



Rough-out Technique

Rough-out carving is actually no different from regular methods – either raised, inverted or silhouette. Only the effect is different because the design is carved and stamped on the flesh side of the leather, rather than the customary grain side.

Silhouette Carving, Inverted Carving, or Regular Carving and Stamping can all be done on the “Rough” side of the leather. Carving and stamping procedures are identical to the Silhouette, Inverted, or Regular carving methods. The same designs and carving techniques can be used for Rough-Out carving.

Case the leather as usual and before carving, remove any wax residue or coatings from the flesh side. This is important so that the water and finishes will absorb evenly.



Transfer the pattern in the usual manner, be sure all lines have been traced before removing the pattern. Press firmly with pencil or ballpoint stylus as the impression often does not show too clearly on the flesh side.

Cut the design with the Swivel Knife. Keep your knife blade sharp, strop it often. One of the disadvantages of Rough-Out carving is that the leather is harder to cut than the grain side. Greater pressure will have to be used. Carve and stamp in the usual manner.

Sanding the Leather – To make a sanding block, tack or glue a small piece of coarse emery cloth or sandpaper to a

wood block. The sanding surface must be flat so that the sanding operation does not touch down into the carved areas.

After carving the design, be sure the leather is thoroughly dry. Then begin sanding the leather in a circular motion. Use plenty of pressure and rub vigorously in all directions to obtain a nice even suede effect. After sanding, blow loose particles out of carved areas or brush them out with a soft brush. **Cleaning the Rough-Out**—Cleaning the Rough-Out is very simple. Re-sand as previously described, and the leather is like new.

Filigree Work

HOW TO FILIGREE THE LEATHER

Filigreeing is done by cutting out the background part of a design. Suede, felt or light weight leathers may then be used behind the work to show through and emphasize the design. This works well on most carving leathers.

The Importance Of The Design

Proper design is important for **FILIGREE** work. The background areas should be well balanced. Long, pointed stems and similar areas of design should be tied to portions of the design so that no loose ends can be snagged and pulled up. Slight modifications on some patterns can make them suitable for filigreeing. Study the simplified examples below.



POOR DESIGN FOR FILIGREE

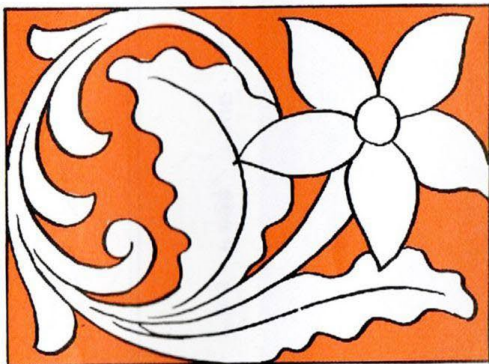

Background areas are too unbalanced and open. Segments of the design have too many loose ends.

ACCEPTABLE DESIGN FOR FILIGREE



Note how design has been "closed"....tying leaves, scrolls, petals, etc., together. Background is more balanced.

CARVING THE DESIGN TO BE FILIGREED

If the design is to be filigreed

The same procedures apply as for regular carving**except for the background**. All beveling should be completed in background areas to raise the design. However, it is not necessary to use the background tools.

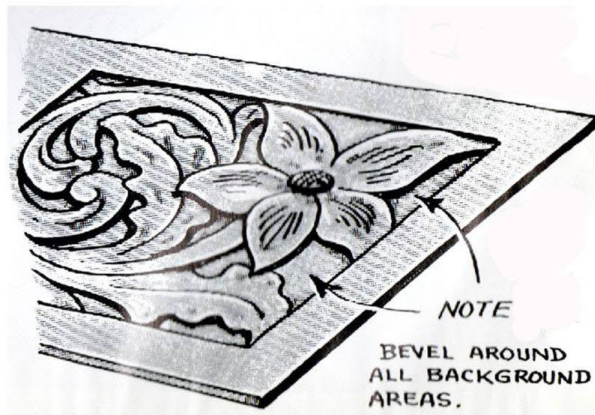

TOOLS USED TO FILIGREE THE LEATHER

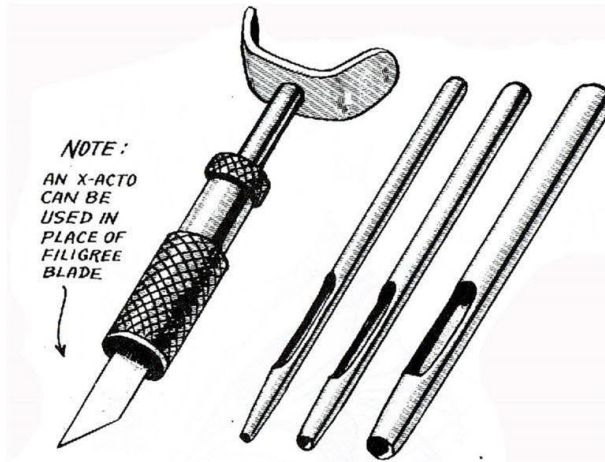

NOTE:
AN X-ACTO
CAN BE
USED IN
PLACE OF
FILIGREE
BLADE.

Filigree blade
To fit into
Swivel Knife
Barrel

ROUND DRIVE PUNCHES
Of assorted sizes.

Suggested sizes for most
common use:
0 — 2 — 4 — 6
Other sizes may be required.

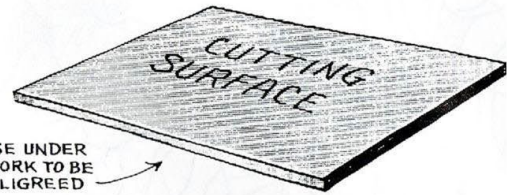

Some good cutting surfaces are :

poly cutting boards,
rubber cutting boards,
a piece of **heavy linoleum glued** to a smooth board,
or a couple layers of **smooth, heavy leather.**

A cutting surface goes under the work to be cut out. It needs to be a smooth surface that protects the table top and the sharp edge of the cutting tools.

These cutting surfaces are good for filigree work, cutting stencils, punching holes, and so on.

The pattern is tooled—START TO FILIGREE THE LEATHER

Examine the design.

In all of the small, curved areas use the proper size round drive punch, that fits the area, and punch out. Place the leather on a firm cutting surface for clean, smooth holes.

The purpose of using the punches is that the tiny curved areas may be difficult to cut with the knife blade.

NOTE:

Always use a rawhide, polymer, or wood mallet on the drive punches....**NEVER** a steel hammer!

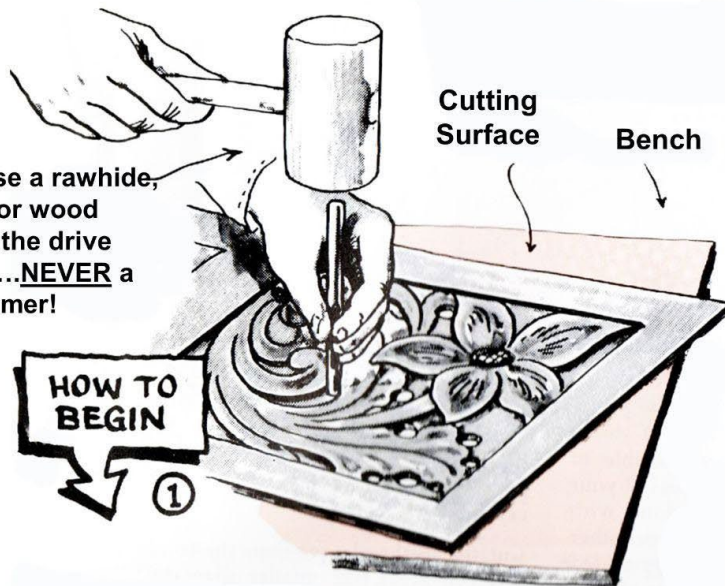

CONTINUE TO FILIGREE THE LEATHER

Use firm downward pressure. Cut through leather with one stroke.

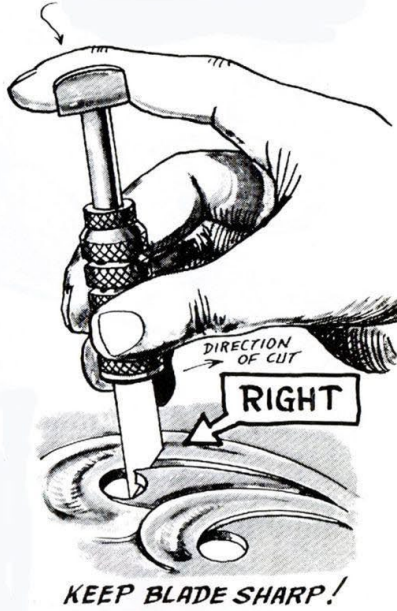

2.

Begin cutting out the background with the filigree blade or X-Acto knife.

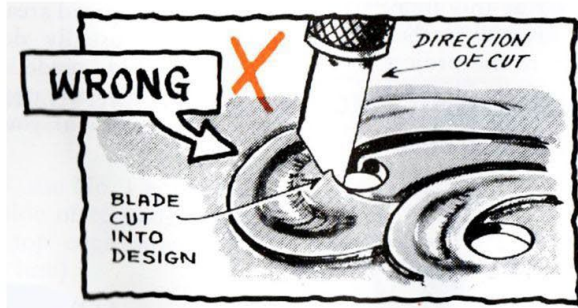

Always cut away from the holes, or corners.....never towards them.....as a slip could be disastrous and ruin the carving or weaken the structure of the design. Do not lean the knife to left or right; prevent undercutting. Be sure to place the leather on your cutting surface.

Alternatively, the entire background may be removed with punches. A one-prong lacing chisel is handy for small areas because you can see exactly where it will cut before striking with the mallet. There is little danger of it slipping out of place. Experiment to see what method works best for you.

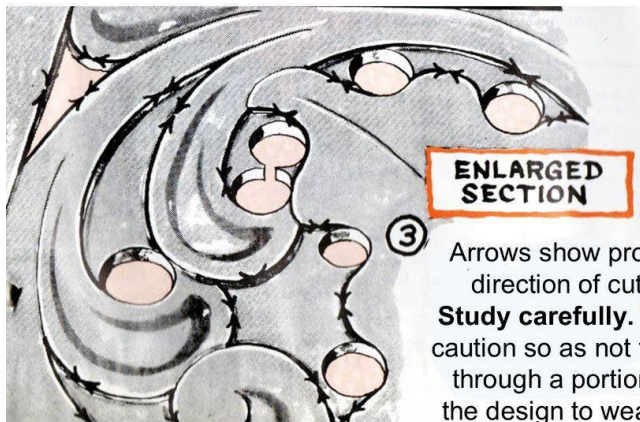

3 Arrows show proper direction of cuts. **Study carefully.** Use caution so as not to cut through a portion of the design to weaken the filigree structure.

After filigreeing the design, do all the dyeing or coloring at this time paying attention to the edges of the filigreed areas. Apply the finish dressing to the project working the dressing into all the filigreed areas. Wipe off all excess...front & back. Allow to dry thoroughly.

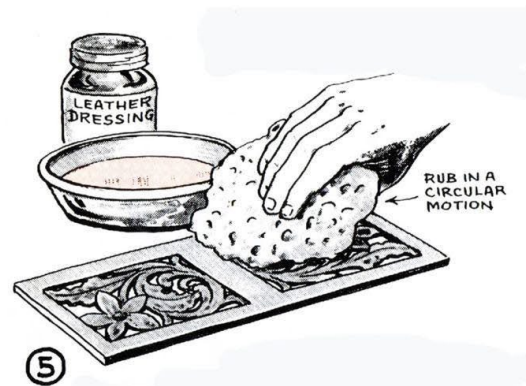

Applying the back-up leather to a filigreed project.

⑥ Many variations are possible to back up the filigreed areas of your project.

This is usually done with gold or silver kid, suede, or other lightweight leathers of a variety of colors.

Use the color of your choice.

Cut the leather larger than the total filigreed areas, yet smaller than the outside dimensions of your project, as shown above.

Skive all edges to a feather thin edge.

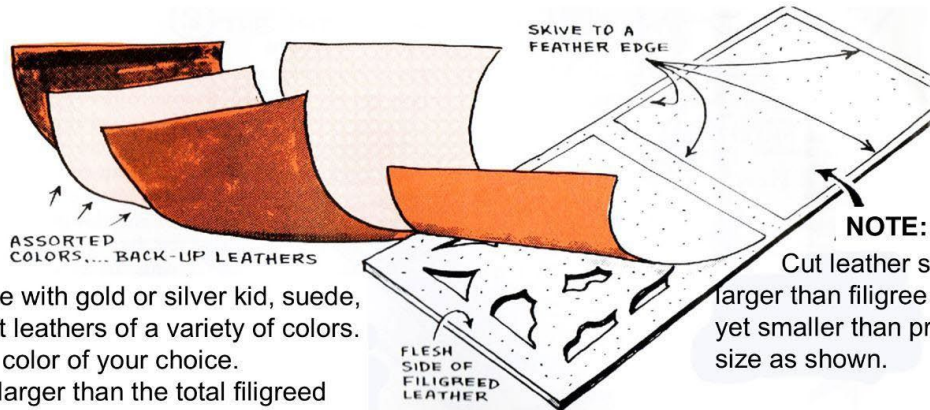

NOTE:

Cut leather slightly larger than filigreed area, yet smaller than project size as shown.

To fasten back-up leather to project, apply strong bonding cement to flesh side of filigreed leather. Spread evenly with spatula...do not cement in filigreed openings. Press back-up leather in place before cement dries...to insure adhesion. Do not apply cement to back-up leather.

Back-up leather

⑦

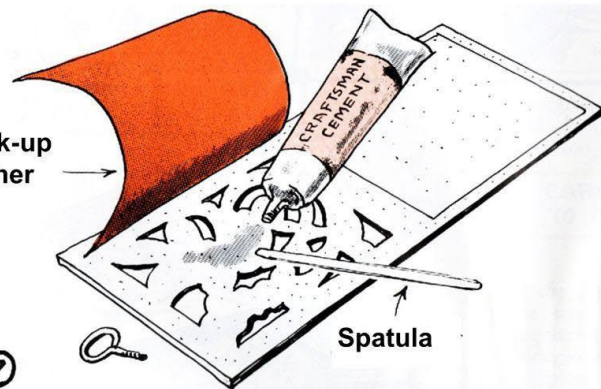

Spatula

If a large project, or glue sets up too fast, cement a small area at a time. Lay back-up leather down, press in place. Fold un-cemented area back up (see above) and apply cement to another small section. Repeat until project has been completed. Caution...to much cement will run down into the filigreed openings. Some experience may be necessary to avoid this.

Cemented area

⑧

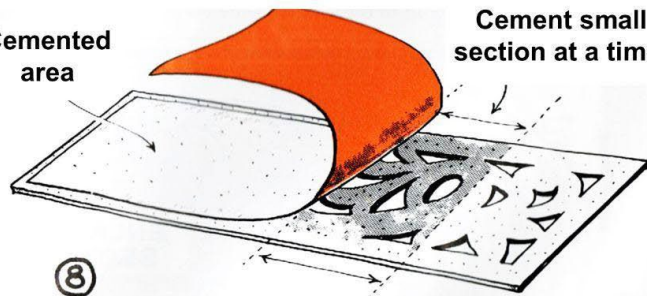

Cement small section at a time.

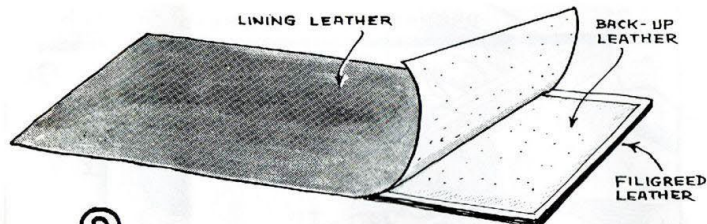

⑨

After cementing the back-up leather in place, cement a lining leather over entire project. Use a skiver, lightweight goat or calf leather. Cut slightly oversize when possible; trim excess after cementing.

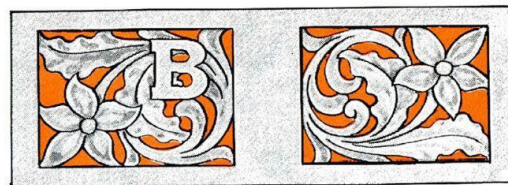

10. Trim leather to correct project size. The project is ready for assembly.

Figure Carving

Persons, animals, or objects may be carved on belts, wallets, book covers, or other items. This is called figure carving. For example, these images could be part of a pictorial setting or part of a floral carving. Successful figure carving is based on desire, practice, persistence, and observation.

Figure carving is similar to floral carving except it may be more difficult. There are smaller details and many depth planes required with the swivel knife and stamping tools as you try to achieve a three-dimensional effect.

Patterns often show dotted lines. These should be traced and transferred lightly to the damp leather but should not be cut with the swivel knife. They are guidelines for beveling and shading contours and muscles.

DO NOT CUT DOTTED LINES ON PATTERNS. (Full sized patterns are in the appendix.)



Usually, the foremost objects are cut first.

Picture the figure in your mind. On which side of the dotted lines should beveling be placed to emphasize the muscle structure you want? Where should the figure be shaded to show how light strikes it?

Various sized bevelers are helpful in figure carving. Use the heel of bevelers to slope and mat down away from figures. This creates an illusion of depth. Don't worry about tool marks. They will be smoothed out later.

The modeling tool is very important in figure carving. Use the spoon to round edges of figures to make them look real and to smooth out rough beveling marks. Use the point for fine details and as a tracing stylus. Scratch in hairlines with the point of the spoon or use a hair blade in the swivel knife. Add facial expression and press in the nostril and corners of the eye with the point of spoon. Shape the eye round. Do not smash down the eyeball.

FIGURE CARVING —creating a figure step by step.

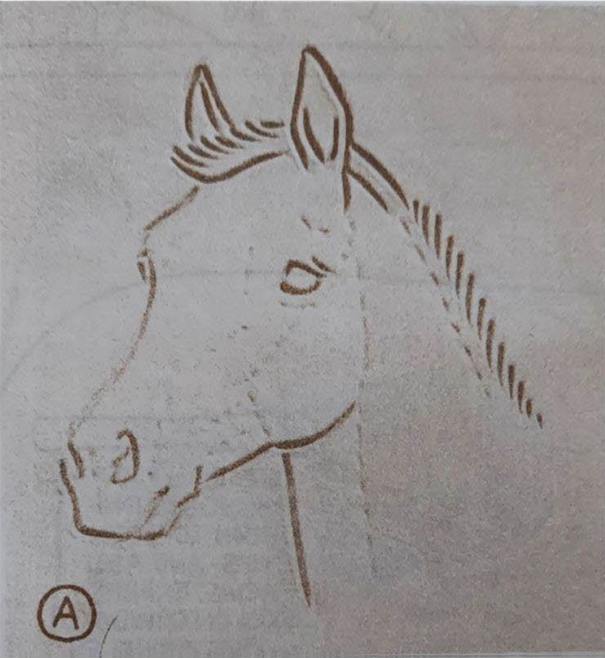

A. Trace and cut. DO NOT CUT DOTTED LINES....they are merely guidelines to aid in beveling.

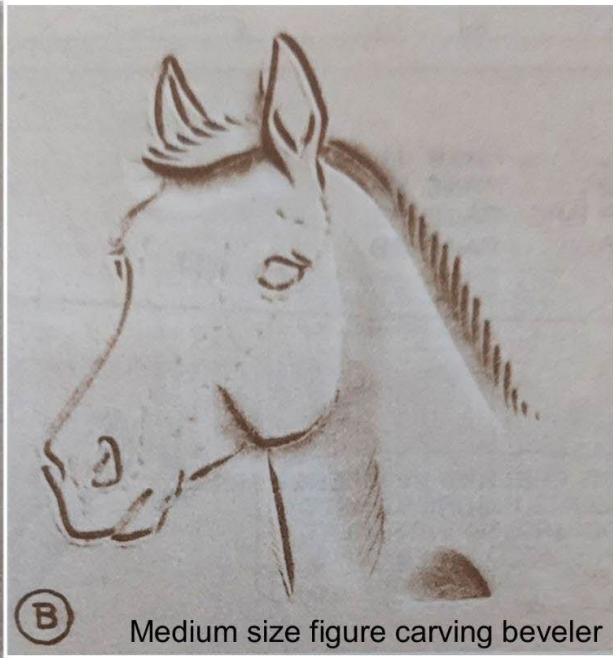

B. Medium size figure carving beveler
Bevel deeply under jowl and foretop; medium on throat. The tool marks show how to “walk” the tool.

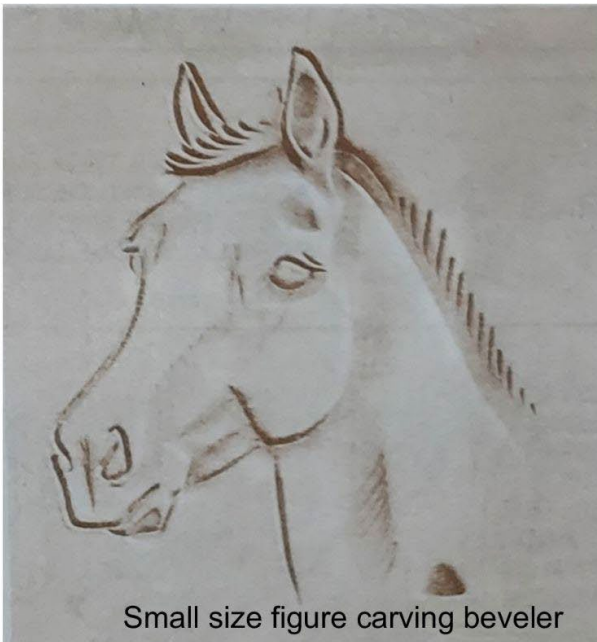

Small size figure carving beveler

Using the dotted lines as your guide, use small figure carving beveler to rough in the temple, nose, and under eye.

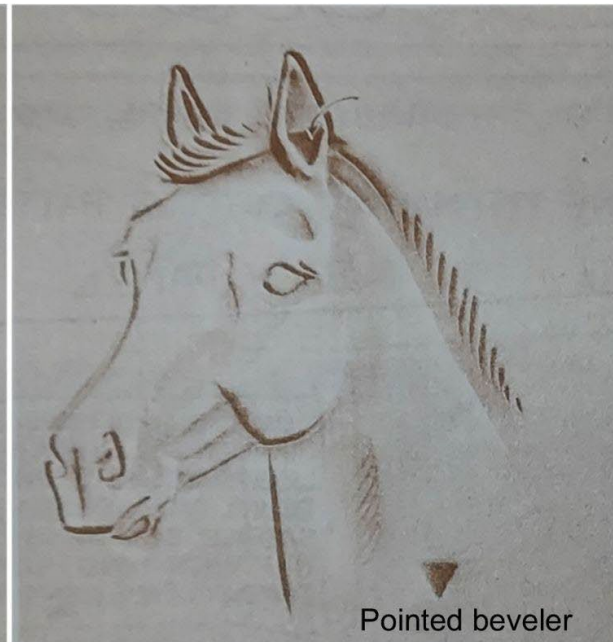

Pointed beveler

The arrow near the horse's eye indicates the use of the pointed beveler.

FIGURE CARVING—creating a figure step by step (part 2)

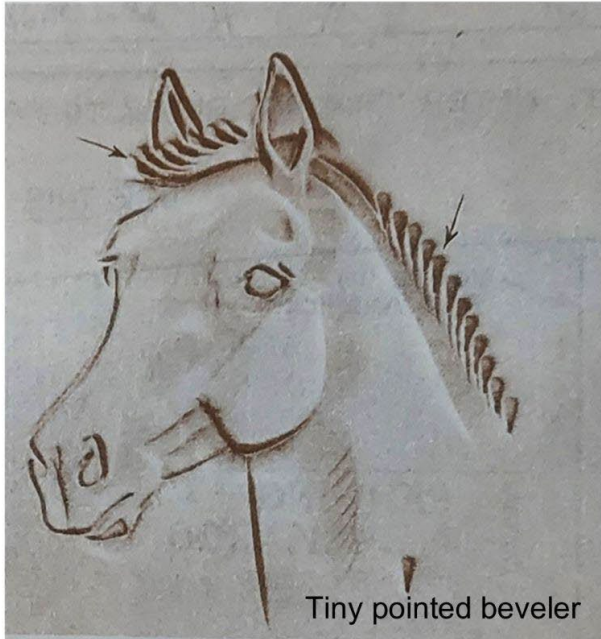

The tiny pointed beveler adds depth to the mane and foretop.

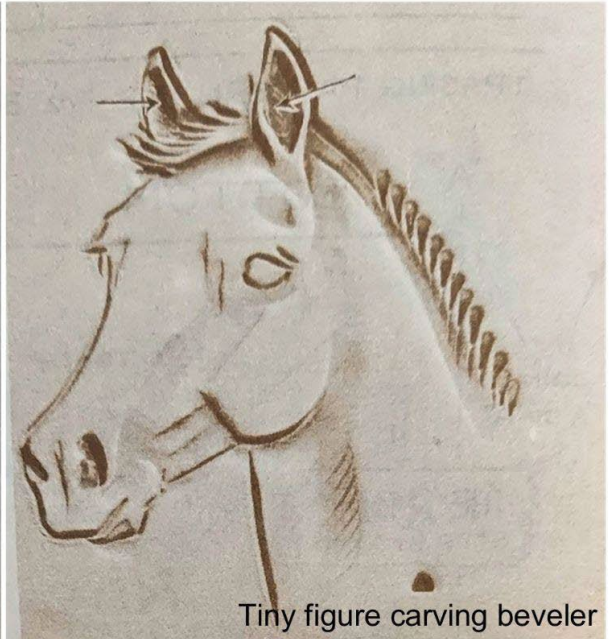

The tiny pointed figure carving beveler bevels and adds hair effect inside the ears; roughs in the nostril.



Use small under cut bevelers (some times called a lifter) inside nostril and to bevel around the eye ball.

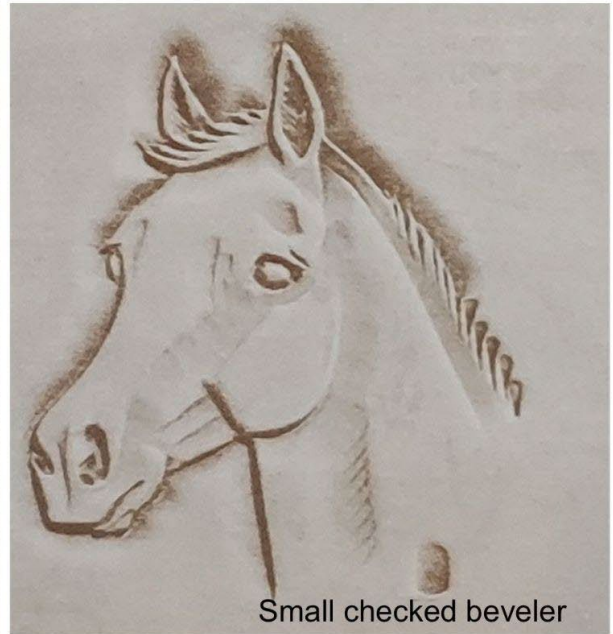

Bevel around head. A larger checked beveler may be used on long cuts.

FIGURE CARVING —creating a figure step by step (part 3)



The arrow shows use of pointed matting tool. Matt background with larger matting tool and hard to get places with smaller.



Smooth all bevels with the spoon end of modeling tool. Use smaller modeling tool for small places.



Use the point of small figure carving modeling spoon to round the eye and add expression, also to scratch in mane and foretop.



Hold lined beveler as shown above and use short, pulling strokes to add the hair lines. Could also use a hair blade in the swivel knife handle.

Regional Styles

Over the history of leather carving, different regions of the country have inspired and developed their own distinctive styles of floral leather carving. Four main styles include the Sheridan Style, Texas Style, Arizona Style, California Style, and Northwest Style. The differences between traditional Western leather carving and the regional styles are the size and details of the features. Some of the design flow can be different, but traditional Western carving uses many of the same techniques as the various regional styles. These styles have provided a foundation upon which craftsmen have added their own interpretations over the generations and created their own unique styles. The patterns and designs used in Western floral carving have evolved over time and will continue to do so inspiring new generations of leathercrafters.

Sheridan Style carving is widely popular and gets its name from Sheridan, Wyoming, where the Rocky Mountain Leather Trade Show has been held. As leather workers from around the world came to this show and saw the style of carving that was being done in the area, the popularity of this name grew. The Sheridan style has a circular flow of patterns with flat and open flowers. The scrolls are usually open ended and not closed to a tight knot.



Texas Style carving was originally not confined to Texas and was used in other parts of the west. The style is often a basic circular pattern. A variety of flowers are used but are not mixed on a particular design. Scroll elements are used and filler leaves or “stickers” are often fat on the ends. Texas style carving uses the matting or checked style background stamps for than other styles.

The Arizona Style uses a variety of flowers. The acanthus leaf and the scroll are used a lot to create flow to the design and as space fillers. The flower is always the focal point of the design, and the stem of the flower is often wider than other styles. Long stems are usually textured with the camouflage tool.



The California Style has several distinctive features that can be seen in other regional styles. Those features likely originated in California, where the leathercraft industry was greatly influenced by many developments. Many great leather craftsmen with influence in the industry got their start in California. Among the features originating in California was a circular flow to the designs that existed long before the Sheridan Style. The California Style uses a lot of buds, more stickers, and a veiner tool rather than a pear shader and swivel cut. Scrolls are seldom used, and the acanthus leaf is almost never used. California Style uses flower center stamps and a lifter along the scalloped edges of petals and leaves.

The Northwest Style does not always follow in a circular flow. There are a wide variety of flowers that are used and often they do not expose their centers. The use of a twisted leaf or flower is unique to the Northwest Style. Scrolls are often not seen in these designs, but you will see a variety of buds and broad leaves used to fill space



Pictorial Carving

Pictorial carving is when you figure carve a portrait and/or scene on leather. Select one or more pictures, scenes, or portraits to carve which are appropriate for your intended use and match your ability. Below is an example of a pattern and a finished project for pictorial carving. Full size patterns are included in the appendix.

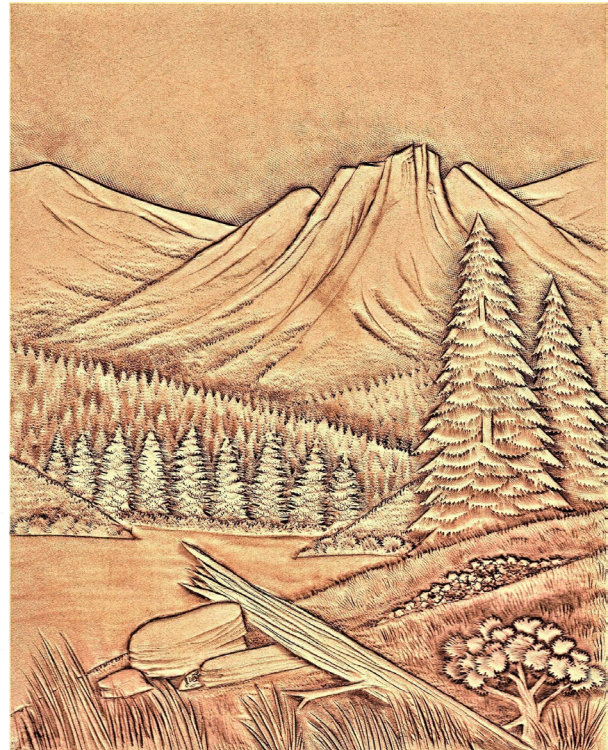
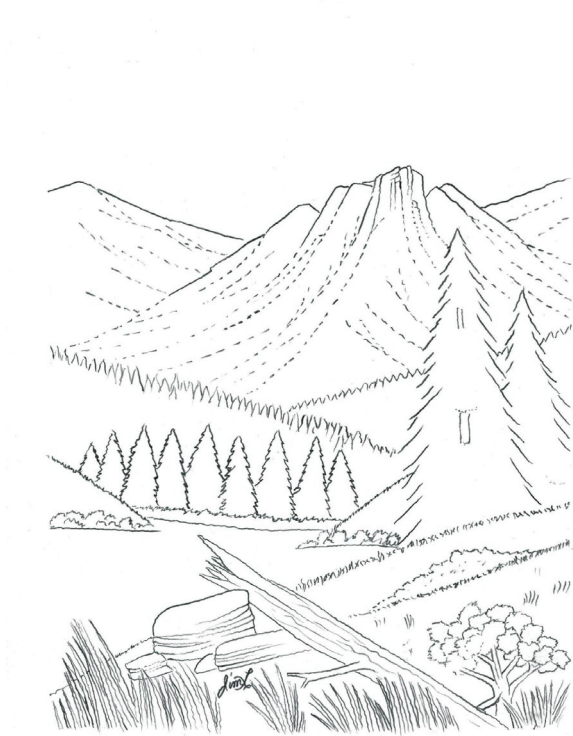

You may dye and/or shade your picture with one or more colors, using techniques explained in Chapter 7 - Coloring for Leather if you wish. Frame or mount pictures as appropriate.

Framing and Mounting Pictures

A frame is used to enclose a picture, to give it emphasis, and to add to its beauty. It should harmonize both with the picture and the room in which it will be used. A frame can also be carved or stamped around the border of your project as part of the design to give it a finished look. Here are some framing tips:

- The frame color should be in harmony with both picture and wall. A guide is to select a frame that is not quite as dark as the darkest color in the picture; however, it is all right to select a lighter side.
- Frame lines should emphasize lines in the picture. If dominant picture lines are simple, complex, straight, curved, etc., they should be repeated in the frame.
- The subject of the picture influences the choice of a frame.
 - Simple frames are appropriate with pictures of distant scenes and with elaborate, colorful, or detailed pictures.
 - Frames that look worm-eaten or weathered are suitable for nature subjects used in an informal room.
 - Sporting pictures might have boldly colored or black frames of flat wood molding.
 - Subjects that suggest strength require heavier frames than pictures with more delicate subjects.
 - Strong colors or diagonal lines in pictures call for heavier frames than do weak colors or horizontal lines.
- The frame width may be determined by the size of the picture. Narrow frames are usually best on small pictures, while wider ones are used on large or heavy-looking pictures. The frame should not overpower the picture.
- Leathercraft items usually do not have glass covering them in a frame.
- Another technique is to tool a “frame” in the leather around your design if appropriate.

Leather pictures are not always framed. They may be mounted on weathered wood or other materials. The colors and lines of the picture should be repeated or enhanced by the material on which it is mounted.

Chapter 6—Preparing Leather for a Finish

Cleaning Leather

It is extremely important to keep the leather clean. Be sure your hands and tools are clean throughout the leathercraft process. Finishes need to be applied to a clean leather surface. If the surface of the leather becomes soiled through the tooling, stamping, and handling process, a final cleaning may be necessary, but only clean if needed. A Q-Tip can be used for small areas.

For lightly soiled leather surfaces:

1. Clean with lemon juice on a lightly dampened clean white cotton cloth or paper towel.
2. **IMPORTANT:** Rinse with clear water on another cloth. Wipe or pat dry.

For heavily soiled leather surfaces:

1. Use a mild solution of leather bleach or oxalic acid. (**CAUTION:** Oxalic acid is poisonous. Be sure to read the label.)
2. Try a leather bleach solution or oxalic acid solution on a piece of scrap leather first.
 - a. **IMPORTANT:** If the solution is too strong or old or leather is not properly cleaned after the solution is used, the leather will take on a pink cast. This will also change dye shades. (Make sure all the acid is flushed out.)
3. Apply the bleach solution sparingly to the carved leather with a damp sponge.
4. Do not saturate the leather.
5. A light scrubbing motion may be used to clean stubborn spots.
6. Be sure to sponge the leather with clean water after cleaning with either solution.



Be sure that the surface area is dry and clean of any dirt, dust, or other matter before dyeing or applying the final finish.

Edge Finishing

Edge Beveling

The edges of most unlaced articles may need to be rounded for a more professional appearance. Always use an edger or edge beveler to round off or bevel edges on both the grain side and the rough or flesh side of the article. The edge beveler cuts only at the proper angle, approximately 40°. It takes practice to maintain the right angle, so it is a good idea to work on a piece of scrap leather of the same thickness first.

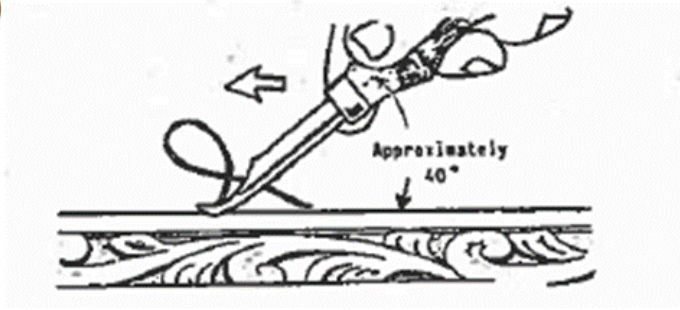

When edge beveling, hold the work firmly on table or bench with the free hand. Hold the tool at the proper angle to the work and with firm pressure push the tool along the edge. A good bevel is indicated by one continuous “string” of leather cut from the beveled edge.

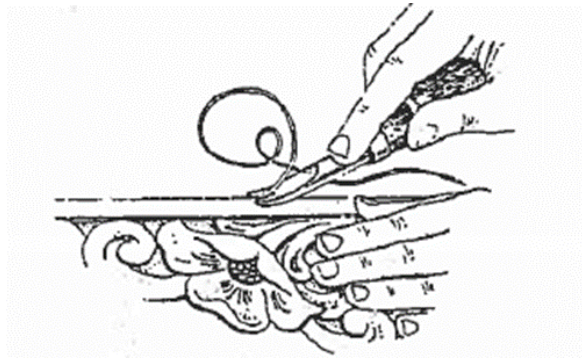

NOTE: If leather is to be stained with antique and/or the edge of the leather is to be dyed, edge beveling should be done first.

Edge Burnishing

Burnishing the edges adds to the “finished look” of leather articles which are not laced. Burnishing is done after edge beveling. Burnishing means smoothing the fibers along the edges of an article, giving them a rich brown color. Use this technique on belts, straps and other edges not covered with lacing.

The edges may be dyed in addition to burnishing. However, such a dyeing should be completed before burnishing as burnishing closes the pores of leather so the leather will not accept dye. To burnish edges, follow these directions:

1. Moisten the beveled edges of the article with a sponge.
2. Rub a circle edge slicker or the appropriately sized notch in a burnishing tool briskly back and forth along the edge, while holding work firmly on the edge of the table.

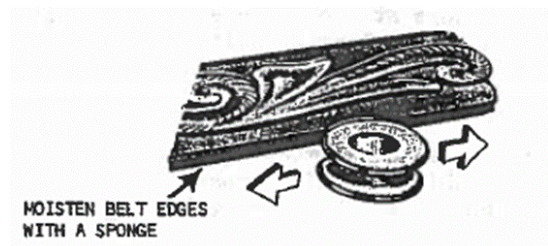

3. Burnishing wax can be applied for a smooth finish and protection.
 - a. Rub in well to eliminate stickiness.
4. Use the edge slicker again over the wax. Or you may put finish on the edges.
5. With proper use and a lot of rubbing, the edge should become glass smooth.



Another way to finish edges is to dampen the edge and rub it with a piece of canvas.

[How To Finish Exposed Edges On Leather](https://www.youtube.com/watch?v=bTzT8PynuKk) (<https://www.youtube.com/watch?v=bTzT8PynuKk>)
Tandy Leather Video with George Hurst

Chapter 7—Coloring for Leather

Dye/stain and paints may be used to improve the appearance of your article. Vegetable tanned and bark tanned leathers are most suitable for carving and dyeing as they are natural or neutral colored which makes it easier to apply dyes/stains and paints. Dyes/stains can be either water-based, oil-based, or alcohol-based depending on the effect one wants. Dyes/stains penetrate and soak into the leather. Paints sit on top of the leather but have more color varieties than dyes/stains. Along with the different kinds of products to color the leather, there are a variety of techniques to color leather.

Products for Coloring Leather

Alcohol-Based (Spirit Dyes)

- Powder pigment dissolved in alcohol
- Quick penetration
- Seeps into fibers well
- Evaporates to leave pigmentation
- Dries quickly
- Does not maintain the suppleness of leather as well as water and oil.
- Strong chemical odor – apply in well ventilated area
- Best applicators - cotton or felt swabs/daubers, sheep shearling or wad of absorbent cotton
- Solvents for thinning and cleaning - Methyl Hydrate or Methyl Alcohol

Oil-Based

- Oil pigment in alcohol
- Better coating and penetration
- Dries slower than alcohol-based but not as long as water-based
- Maintains suppleness of the leather
- Some odor but not as strong as alcohol-based
- Can be thinned with turpentine
- Best applicators - cotton or felt swabs/daubers, sheep shearling or wad of absorbent cotton
- Solvents for thinning and cleaning - Methyl Hydrate or Methyl Alcohol

Water-Based

- Powder pigment dissolved in water with resin added for penetration
- Good coating and penetration
- Takes longer to dry
- Maintains suppleness of leather
- No odor
- Less rub off than alcohol-based
- Best applicators - flat lettering brush or round squirrel brush
- Solvents for thinning and cleaning - water

Paints - Acrylics, Enamels, and Lacquers

- Pigment suspended in acrylic polymer
- Good coating - does not penetrate
- Is flexible on the leather
- Dries quickly
- Some odor but not as strong as alcohol-based
- Best applicators - brushes of different sizes appropriate for design
- Solvents for thinning and cleaning - Acetone or prepared thinners

General Suggestions for Coloring Leather

Before you start any of the techniques for coloring leather. Read through the following suggestions and tips to make the experience a favorable one.

- Complete all carving and thoroughly clean the leather before dyeing, staining, or painting it.
- Always cover the work area where dye is used. Lots of newspapers work well.
- Prepare a work area by having everything within reach and make sure you are seated comfortably.
- Be sure to have enough dye, stain, or paint to complete the project.
- The same color from the same manufacturer, in two separate bottles may produce a different color.
- The leather should be almost dry before applying dye, stain, or paint.
- Avoid getting dye, stain, or paint on the back side of the unlined leather articles.



It is important to try out any coloring technique on a scrap piece of leather to be sure you get the effect that you want as all leather does not take color the same due to tanning methods. The type of leather may also affect how the coloring looks. It is a good idea to test out and/or practice any coloring technique on a scrap before applying it to your project. Wait until the test piece dries as intensity of dye, stain, or paint will change when it dries.

- Place the bottle conveniently so you can dip the brush or dauber easily yet not reach across the leather. It is best to use small wide mouth jars for dyes.
- Always begin with the lightest shade and end with the darkest.
- Have only one color opened so you will not accidentally dip into the wrong bottle.
- Hold the brush in an almost vertical position when background and shade dyeing.
- Never have the brush overloaded where it may drip on an unwanted area. A small amount in a small container aids in loading your brush correctly.
- If your hand isn't steady while dyeing, you can brace it on your other hand.

- Be sure to wear gloves, ventilate the room, and prepare everything you need, such as paint brushes, scrap rag, and your dye, stain, or paint ahead of time.
- Make sure to clean brushes after use first with solvent and then with soap and water.



CAUTION: Protect hands from direct contact with oil and spirit solvent dyes as stains are difficult to remove from skin. It can even go through rubber gloves.

Techniques for Coloring Leather

Techniques for coloring leather are antique finish, background dyeing, two-tone finish, solid color dyeing, block dyeing, shade dyeing, painting with acrylics, dry-brush, and airbrush. The following instructions describe how to do each of the techniques from the simplest to the more complex. Dyeing leather evenly takes some know-how and skill that comes with a lot of practice.

Antique Finish/Two Tone Finish

Antique finishes come in various shades of brown and are used to achieve color uniformity while keeping the full appearance of the leather's beautiful grain surface. Using an antique finish makes the article darker and lighter depending on the tooled design. A more defined two-tone finish can be achieved by applying a clear finish to parts of the design before the antique finish is used. Make sure the clear finish dries completely before applying the antique. Antique finish can be applied on both undyed and dyed designs. The following explains the process to apply an antique finish:

1. Apply a very light, but consistent, coat of moisture to the grain surface and allow a few minutes for the moisture to penetrate. This "primes" the leather and assures more even coloring.
2. Dip lightly moistened applicator (large brush, lamb's wool, soft cloth, paper towel, or small sponge) in antique finish.
3. Carefully wipe excess from the surface of the applicator on the side of the container.
4. Two ways to apply:
 - a. If the leather surface has been carved and tooled, begin applying antique finish at the center of the carved design and work out
 - b. Begin at top of project and move across the project downward
5. Use a circular motion and apply antique finish over desired surface. Be sure tool marks, cuts and depressions are covered evenly.



6. Wipe off surface excess as directed, with a smooth, dry cloth.



7. Brisk and thorough buffing with a soft, clean cloth will further amplify the beauty of the antique finish.

Background Dyeing

Dyeing the background makes it appear to recede, so the carving and tooling stands out. Backgrounds should be dyed for full and complete coverage. Most background dye is applied where the pattern has been tooled with the backgrounder.

There are two methods of background dyeing with a brush; use either one or a combination of both. For a professional appearance, dye must be on the background only and not on the raised edges of the carved design. Here are tips for background dyeing:

1. Use a No. 3 Red Sable brush for general background dyeing. It holds a good supply of dye yet points well for detail work.
2. The brush should never be submerged in the dye. Dip it into the color not more than three-fourths of its length. Then touch the brush to the inside of the bottle to release the overload.
3. On a piece of scrap leather, twist the brush clockwise to point the bristles.
4. Always touch the brush to scrap leather first to remove excess dye before applying to the article. Too much dye will run and “bleed” over the edges of the design.
5. **First Technique - Method A**
 - a. Hold the brush straight up and down. The entire article can be dyed without turning the leather to any great degree.
 - b. The brush is alternately leaned slightly one way or the other to avoid getting dye on the raised edges of the design.
6. **Second Technique - Method B**
 - a. Hold the brush at a comfortable angle.
 - b. Dye one-half of all background areas that can be easily reached without straining the hand. Pointed areas are readily accessible with this method.
 - c. Turn leather and complete dyeing. Overlap dye to be sure of full coverage.
7. Begin dyeing in the open areas.
8. Start in the widest area and work toward the fine points.

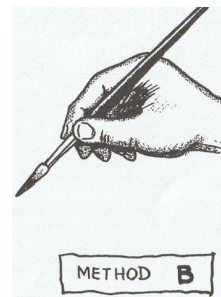

9. When most of the dye has been exhausted, carefully point the brush and dye into pointed areas.
10. Use short pulling strokes to cover the area working toward the raised carved edges.
11. Turn the leather as often as necessary to facilitate dyeing in the difficult areas. With the brush almost dry there is less chance for color to “bleed” over the edges in the small, pointed areas.



Tip #1: When dyeing large articles, place a piece of clean cardboard or non- absorbent paper over your work between the dye bottle and working area to aid against accidentally spilling dye on your article. This also protects the leather from body oil which may accumulate on your hands as you work.

Tip #2: For neatly dyed edges left uncovered by lace, clip a piece of heavy felt in a clothes pin, dip in dye and pull quickly along the edge.

Solid Color Dying

Solid color dying can be done with all types of dye to make the project all the same color. The type of dye used will determine the applicator and technique to be used. Always keep the area to be dyed in full view.

Oil and Alcohol-based Dye Technique

1. Dip the applicator in color and begin in the upper left-hand corner.
2. Move quickly in a circular motion so each stroke slightly overlaps the last.
3. When strokes of color are too thin, dip the applicator into color and resume motion until the entire project is covered.
4. When dry, there will be darker and lighter spots. One application of dye is usually not sufficient for an even tone.
5. Go over the entire surface again in the opposite direction
6. Dye can also be applied in horizontal strokes back and forth then vertical strokes and, if necessary, diagonal strokes.

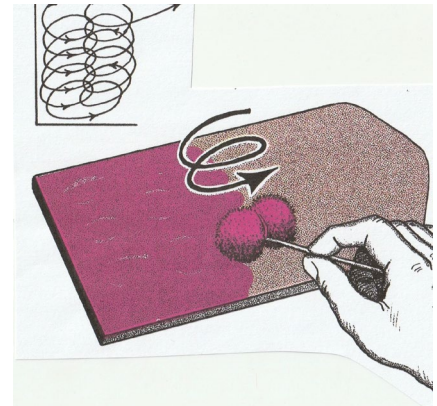

Water Based Dye Technique

1. The edge of a flat lettering brush should appear tapered sharply when wet with the proper amount of dye. Your brush stroke should be from left to right, if right-handed or right to left, if left handed.
2. A round squirrel-hair brush may also be used. A scrap of leather from the article you are making should be handy when using this brush. The brush should be gently touched to the scrap to exhaust any excess dye. The proper dye load should always leave the brush tip pointed.
3. Follow a circular motion so each stroke slightly overlaps the last. When the brush contacts leather, the bulk of the dye is immediately exhausted into the leather. The circular motion redistributes this heavy area evenly over that part of the surface.
4. Use cross and diagonal strokes for second and third applications of dye to obtain a more even job.

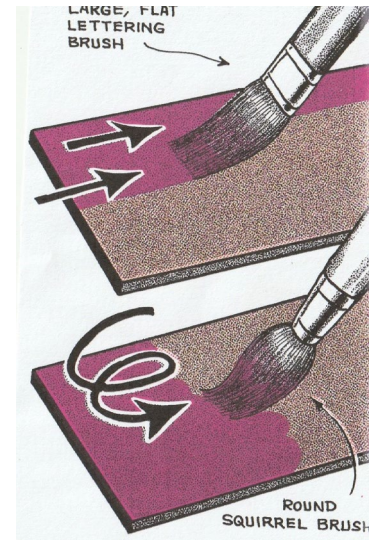

Block Dyeing

Block dyeing highlights the surface area but does not cover the whole item.

1. Wrap a piece of cloth (old T-shirts are fine) a few times around a block of wood and secure it with thumb tacks.
2. Dip a wool dauber into a bottle of dark colored dye (black, dark brown). Wipe off the excess on the rim of the bottle.
3. Apply a small amount of dye on the cloth covered block. Block the dye on a thick pad of newspaper.
4. Rub the block across the top of the leather to obtain a mottled two-tone effect.
5. Repeat until color and effect is what you want.
6. Rub with a soft cloth or sheep's wool scrap.

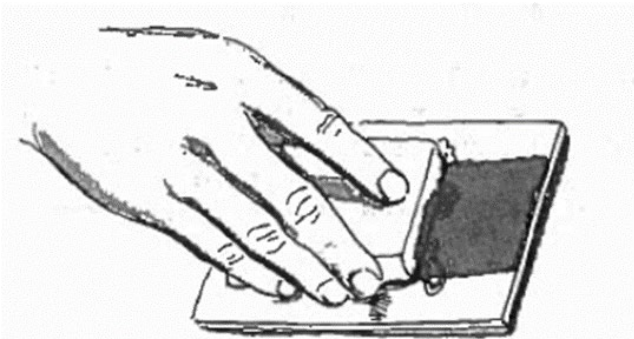

Alternate Techniques for Block Dyeing

Small, tooled areas can first be color accented by using a No. 3 brush or a small cotton swab (paper or wood shaft only—no plastic) dab bright colors (blue, green, red, yellow) into the tool marks. Allow to dry.

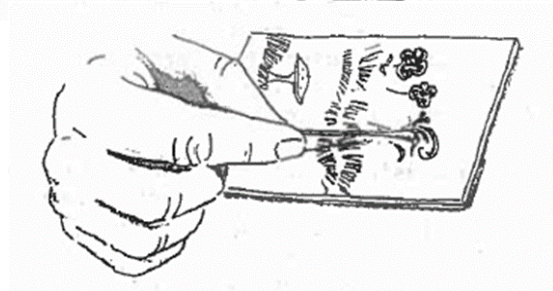

Complete dyeing using the block-dyeing techniques

Shade Dyeing

Monochrome is a variety of shades, all of the same color. Since natural leather is actually a shade of brown, all of the other shades of brown will be in harmony with it. Therefore, dyeing will always be in good taste and harmony when you use shades of brown on leather. The lightest tones of the lightest colors should be applied first, progressing to the darkest tones of the same color.

1. A highly reduced strength of dye should be applied over the entire area to be dyed. This reduced strength should be no stronger than 25 to 1 or approximately 30 drops of color to an ounce of reducer. This strength can be called "zero". "Zero" strength acts as a primer for the colors applied to the article.
2. Other reduction strengths you might use are:

No. 1 - 3 parts reducer to 1-part dye

No. 2 - 2 parts reducer to 2 parts dye

No. 3 - full strength dye

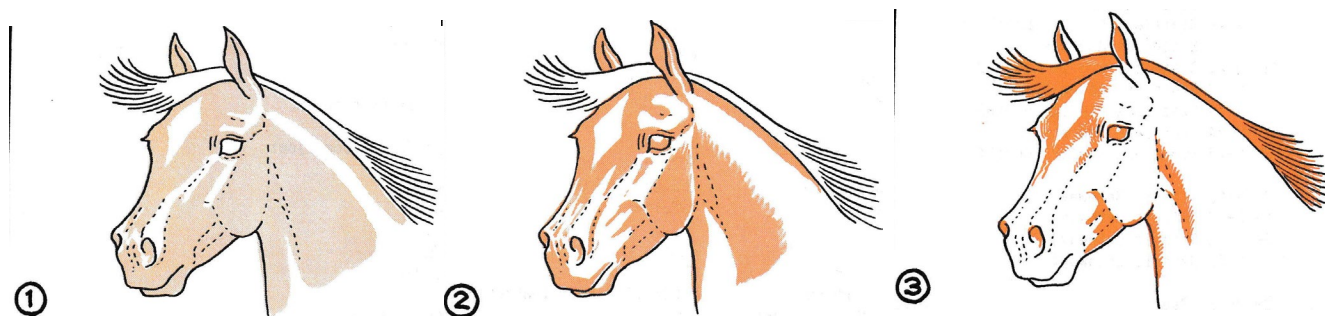

3. Prepare each strength of dye and reducer in advance. Be sure to label the container with the formula.
4. Test each formula for strength on scrap leather. It is better to mix formulas weakly, test and add more dye to your liking. Keep a notebook of formula strengths preferred so you can replenish at a later time, if desired.
5. Always use a clean eye dropper when preparing the formula.
6. Before using a new brush, wash in warm soapy water, rinse clean and squeeze out most of the moisture.
7. To shape the point, lay in the palm of your hand and twist clockwise, pulling it out of the hand as you twist. Repeat the operation two or three times until the brush is well pointed.
8. Always clean the brush before using another color. First wipe the brush with a rag, clean with a reducer, then wipe the brush dry and proceed to the next color.
9. If the brush begins to fray at the point and hinders dyeing, turn slightly clockwise in the fingers as you make each stroke. If fraying persists, it may be due to too much dye that has dried and hardened the hairs at the ferrule. Clean the brush in its proper thinner, wash with mild soap and warm water and reshape the point.

10. You can control the size of each stroke with the amount of dye in the brush and pressure exerted. The three illustrations show from left to right:

- a. Proper direction of stroke with slight downward pressure.
- b. More downward pressure, releasing more dye.
- c. Fine line dyeing after excess has been exhausted from brush. Never try fine line dyeing with a brush directly from the bottle. Brush excess on scrap, twisting clockwise with the stroke to bring hairs to a fine point.

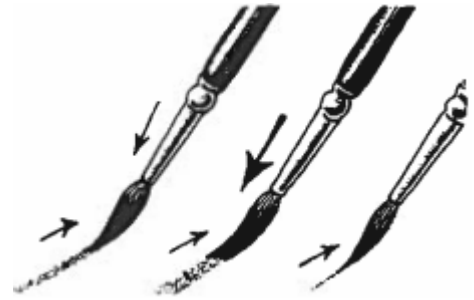

Combinations of colors are handled much the same way as monochromatic dyeing. Mix the full-strength colors until you get the desired color. Then reduce, using the formulas given previously. Many colors can be used as they come in the bottle. Felt-tip pens may also be used.

Special Shading Techniques

Wet-Brush Technique (produces the most intense colors and even tones)

1. Dip brush in dye.
2. Touch brush to the inside of the dye jar and give a slight twist.
3. Then apply dye straight to the leather. This will give the most penetration.

Diluted Color Strengths Technique (as in figure dyeing and floral petal and leaf shading)

1. Hold the brush at about a 45° angle to work.
2. Best results are obtained by quick strokes of the brush, so heavy concentrations of dye are not absorbed in one spot.
3. As the brush is touched to leather, begin the stroke at once and apply considerable downward pressure.
4. Simultaneously twist in fingers to “feather edge” the brush point and widen dye coverage.
5. When the stroke is from right to left, twist the brush clockwise. When the stroke is from left to right; twist the brush counterclockwise.

Dry-Brush Technique

1. The brush is held and used in the same manner as in shading.
2. However, most of the dye is first brushed on a scrap of leather until all excess has been exhausted and only enough remains to carry color to stain the surface of the carving with very little penetration.
3. The strokes are made quickly so dye does not run down the depressions of hair lines and other tiny details.
4. The same methods are used to achieve the blending shades, only dye is applied with a dryer brush

A great deal of practice will be necessary to master the art of shading with leather dyes. Begin with weak solutions of color and practice shading on plenty of scrap leather. Begin with lightest tones, covering all except the highlighted areas. Then, mix stronger color, and gradually decrease the area covered and at the same time blend and darken the shading. The results are very rewarding and carved figures assume a much more life-like appearance.

Air Brush Dyeing

Air brush dyeing requires special equipment including compressor, air brush, siphon bottle, hose, and accessories. Airbrushing, like other dye techniques, requires practice. To prevent darkening at the beginning and end of “brush strokes” you must have the air brush moving. Interesting effects can be achieved with airbrushing.

Using a piece of scrap leather, experiment with the air brush before applying to the final project.

1. Turn the dye flow down and hold the tip about ¼ inch from the leather to achieve fine lines.
2. Then increase the distance between brush and work and note the difference in spray pattern and destiny.
3. Practice outlining and shading on a simple carved design.

Painting Leather

Although painting is essentially another form of dyeing, the color you use is more intense and will add more dimension to the leather project. Acrylics, enamels, and lacquers are used in this technique for coloring leather. Be sure to practice on a scrap piece of leather before painting on your project to make sure products you are using work how you want or are compatible products. They do not penetrate the leather and to some degree hide the grain of the leather.

1. Paints are applied after an article is carved, stamped, and dyed.
2. Stains can be applied after if the desired effect is to darken the paint.
3. Clear finish should be applied to those parts of the design that are not meant to be painted just like in the two-tone technique.
4. If desired a clear lacquer can be applied to the design to semi-seal the pores so coverage is more thorough. Let this lacquer dry completely before painting.
5. Use the shade dyeing techniques with pliable brushes.
6. Cleaning brushes often throughout the painting process will keep coverage more adequate.
7. When paints are completely dry, a finish should be applied as paints will rub off with use.

Chapter 8—Finishes for Leather

Applying Finish

A finish should be applied to a leather article to protect the surface and preserve the appearance of the leather. Some finishes are also made to waterproof and condition the leather. All finishes like dyes should be applied in a well-ventilated area.

Before applying the finish:

1. All tooling of the design must be completed.
2. Be sure the surface area is dry and clean.
3. Make sure applicator is clean
4. Finishes should be applied prior to assembly of the article.

Applying the finish:

5. Put the finish on using a damp sponge, piece of wool, brush, or as recommended in directions on the finish container.
6. Wipe on the stamped surface of the article with a circular motion.
7. Coat the entire surface and allow it to dry. Two or three very light coats of finish are best.
8. Allow each coat to dry and buff before applying the next coat.



Kinds of Finishes

All finishes will alter the leather to some degree. Some finishes are designed to be clear, and some add a tint. The desired effect will determine which finish is best to preserve the finished leather project.

Clear Finishes

- Protects carved design and dyeing
- Dries to a semi-glossy or glossy finish
- Some are more waterproof than others
- May take more than one coat
- Not used for maintenance of the leather
- Most applicators can be cleaned with water.

Oil

- Conditions and protects leather
- Dries to a darkened version of project - no gloss
- Waterproof
- May take more than one coat if leather is very dry

- Can be used for maintenance of the leather
- Usually makes leather softer and more pliable

Liquid Wax Finish

- Protect carved design and dyeing
- Dries waxy but when polished with a soft cloth will have a high glossy luster
- Most are waterproof
- Takes one thin coat. (Thick coats turn white and fill up the cuts and tool impressions.)
- Can be used for maintenance of the leather

Saddle soaps, leather cleaner, and leather conditioners are more commonly used to clean and maintain the life of the leather. They are usually applied in the same way as finishes.

Chapter 9—Shaping and Molding Leather

Shaping and Molding Leather

Leather has the right properties to mold or shape into a holster, a knife sheath or other items that are carried or worn which needs protection.

Using shaping of a pistol holster for an example, finish the construction of the holster and do not apply a finish to it. Make sure an adult helps you with the next steps. Cover the firearm (make sure it isn't loaded) with plastic wrap or other food wraps found in the kitchen. This will protect the pistol from moisture.

Quick case (submerge the leather) in water for a few moments. Drain off excess water and push the pistol into the holster and allow it to take the shape of the firearm. Shape the leather using your fingers and a modeling spoon or a bone folder. After several minutes, remove the pistol from the new case and allow it to dry completely. Once done, a finish is applied to protect the leather from minor dirt and moisture. This technique can also be used for knife cases, book covers, and any other project of the same type.

Molding leather is done by either using a block of wood the size and thickness of the product to be covered or the actual item. Cut leather larger than the item to be covered and case the leather. Using a cell phone as an example, either cut a block of wood the size of the phone or cover the phone with a plastic wrap so it won't get damaged. Place the phone over another wooden surface like a workbench, center the leather over the phone and using a bone creaser, begin shaping the leather around the sides of the leather. Once this is completed on three sides, place brads or small nails into the bottom of the crease and tack them down, spacing them about $\frac{1}{2}$ to $\frac{3}{4}$ inches apart. Do this all around the case keeping the formed leather snug against the phone. Allow the leather to dry, remove the brads, and the new cover is then glued to another piece of leather that will be the back of the new case.

Using an awl and waxed thread begin stitching the two pieces together. Space the holes evenly using the brad holes as a guide for spacing. Once the stitching is completed, trim off the excess leather leaving about $\frac{1}{8}$ of an inch between the stitching and the edge. Apply a protective coat,

allow it to dry and it is completed. This procedure can be used for other items such as a pocketknife, flashlight or any other item.

Sculpting Leather

Leather can be sculpted (shaped) into interesting forms when it is moist and pliable. Instructions may be found for everything from boats to birds, from masks to 3-dimensional figures shaped over modeling materials.

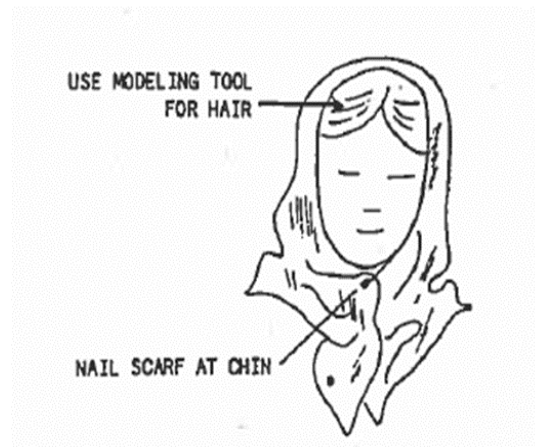

Always use oak tanned leather in sculpting. Water will penetrate this leather quickly, making folding and shaping easy and it retains the shape after it dries.

The weight of leather selected should be determined by the amount of folding and shaping to be done. One and a half to two-ounce oak tanned leather is used for shaping small items over modeling materials. Three-to-five-ounce oak tanned leather is used for masks, etc., where deep, sharp folds are used. Heavier leather may be used when there is less folding and contouring.

The proper moisture content for shaping and folding is the same as for carving. Apply water to leather with a sponge or spray device. Apply to the grain and flesh sides of leather so moisture penetrates all fibers. Allow leather to dry until most surface moisture has evaporated, but inner fibers should still be moist. Shape the leather with your hands.

If you wish to change the shape of a piece of sculpture, simply dampen again and reshape as desired. After the piece has dried, lightly moisten areas on which you wish to add details. These may be added with the modeling tool.

Collages

Collages can be made by gluing pieces of leather on a panel made of plywood, Masonite, or heavy cardboard. The background can be painted with acrylic paint, if desired, be sure it is thoroughly dried before applying leather pieces.

Cut leather of desired shapes – geometric, abstract, flowers, fish, etc. Arrange the pieces on the background; then glue with transparent white resin glue. Apply glue to the flesh side of leather and press into place.

Chapter 10—Leather Fabrication

Leather Cutting Tools

There are many types of tools used for cutting leather. The tools you choose to use may vary depending on your project. There are a variety of knives you can use, like typical craft knives, utility knives, leather shears or scissors, razor blades, round knives, trim knives, precision knives, and rotary cutters. You can also purchase gridded cutting mats to cut the leather on.

Setting Rivets

Rivets are metal tubes with a head on both sides that pass-through leather to secure the pieces together. Refer to Using Hole Punches at the end of this chapter. You need the proper size hole to match the rivet diameter. The length of rivets depends on the thickness of the leather pieces that you are using. A good hard surface like granite with a poly cutting board to protect the stone, or a small anvil should be used when setting rivets.

Domed or Double Cap Rivets

There are two pieces: the cap and post. See the diagram on the next page to determine how the pieces are put together.

The post needs to pass through the leather with a 1/8 inch or less of the rivet sticking out of the pieces you are working on.

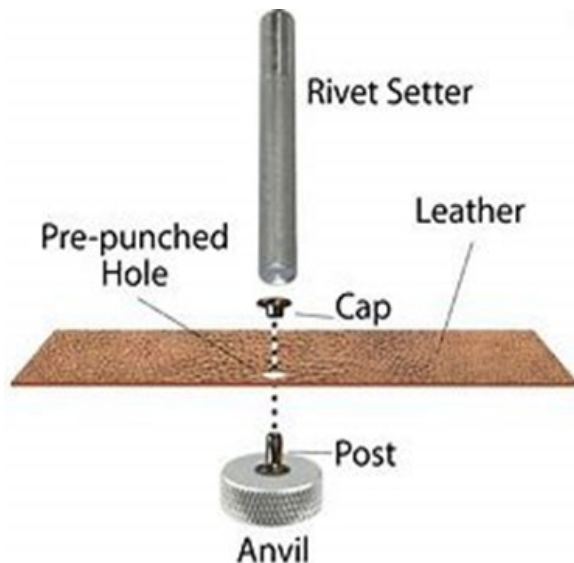

The cap will then be added to the top of the post. Then use a domed rivet driver to drive the cap on to the post. Two or three solid strikes should set the rivet. Always keep the tool straight when setting rivets.

Tube Rivets



Tube rivets are a single piece, when set the tube side of the rivet will split and mushroom out and bite into the leather securing it to the work piece. A 1/8 in or less of the rivet should stick out of the leather pieces you are working with before setting the rivet. As stated above a hard surface needs to be used when setting rivets. When setting tube rivets, you will need to select the proper driving tool that matches the rivet size. Striking the driver two to three times should set the rivet.

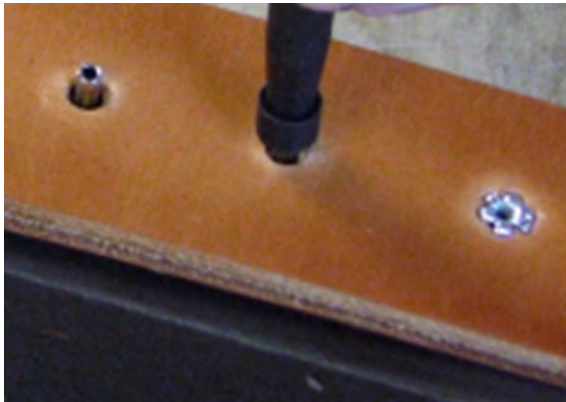

Copper Rivets

These rivets are normally used by saddle and harness makers for heavy duty applications. Copper rivets are a two-piece post and washer type. The post is tapered so when the washer is driven onto the post it will hold steady with friction.

A setter is used to do this. The setter has two functions, one to drive the washers down and to dome the post. After driving the washer to the desired position on the leather the post can be cut off to be set and domed.



Shown here: a punched, post placement, washer set, post trimmed, rivet set, domed rivet.

hole



How To Set a Copper Rivet

<https://www.youtube.com/watch?v=p8Y1k5HKX0o&list=PL2v0zL3aZty8wJ7tcYTLLTrkFkEGXae0V&index=2>

How To Set A Rivet In Leather

https://www.youtube.com/watch?v=zQz11_LNcmw

The Leather Element: How to Set Rivets

<https://www.youtube.com/watch?v=WefWhhi7Fzk>

Setting Snaps

Setting Snap Fasteners (Segma Snaps)

Many different snap fasteners and tools for installing them are available from leather dealers. Perhaps your club would like to buy a multipurpose tool (like a Tandy Snap All Tool Setter) which could be used on different snap fasteners.



Setting
the Cap
and
Socket

The

illustration shows how to set snaps on a belt. The same procedure is used on a key case, pocket of a billfold or any other article.

Be sure to arrange the parts properly so the snap will work right. Place the anvil on a hard work surface with a concave snap cap side up. Position cap in place. Center snap hole in leather over the cap and insert socket through hole in leather into opening in cap.

Insert prong of setter in opening of socket. Strike setter sharply with a mallet, but do not overdo it.

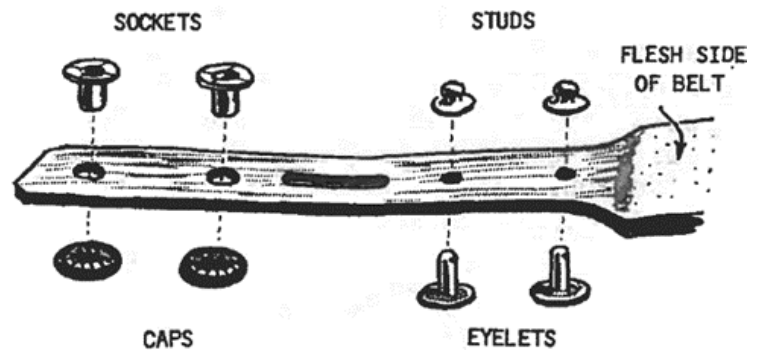

Setting the Stud and Eyelet

To set the stud and eyelet use a large opening for belt snaps and small opening for glove snaps. Place stud in proper opening. Align hole in leather over stud and insert eyelet through hole in leather and into opening in stud. Place the prong of the setter into the opening in the base of the eyelet. Strike setter sharply with a mallet.

NOTE: If you are using belt snaps with finished backs, use a rivet setter. Be sure the eyelet is straight. If crooked, the eyelet might bend and not set properly.

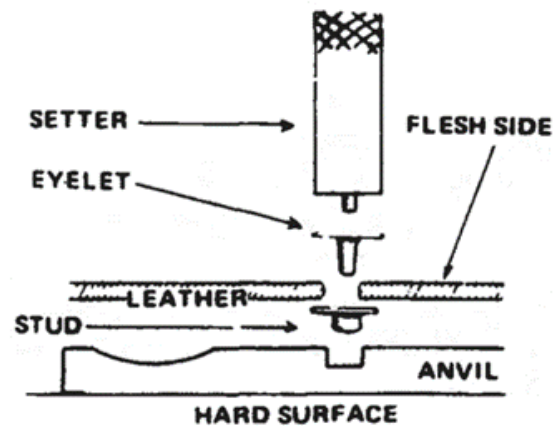
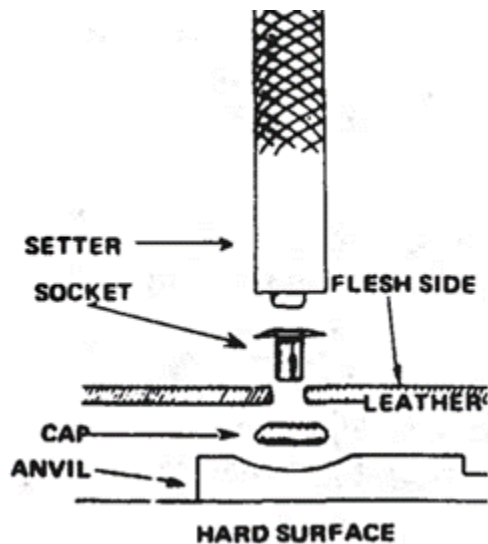

Setting Snap Fasteners On Leather
<https://youtu.be/mwBNL6lluLM>

Installing Leather Linings and Gluing

Proper preparation and installation of linings is vitally important to the appearance and utility of leather articles. After the exterior pieces of leather have been stamped or carved with the desired design, install the hardware such as bag clasps or snap fasteners, if they are part of the article. The under parts of the hardware will then be covered with lining.

For best results, lining material parts should be cut slightly larger than the exterior parts of the article. During carving and tooling of the design, the leather may stretch lightly. If the lining material is oversize, it allows for easier fit on the tooled part. The excess lining can later be trimmed away.

Place the carved leather and lining with the flesh sides up. Apply a thin coating of rubber cement to each. Allow a few seconds for the cement to dry, then carefully align any slots or holes.

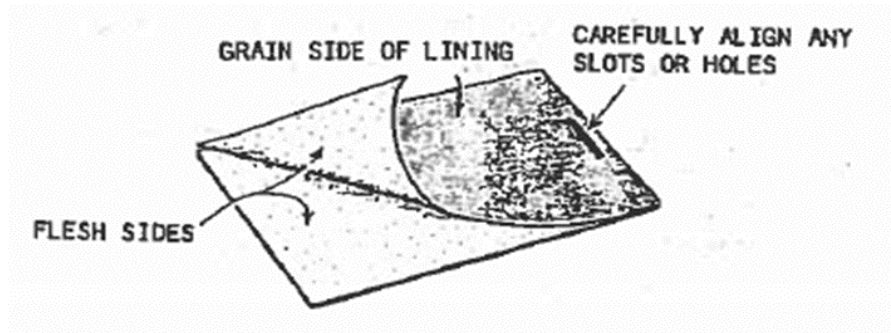

If the lining is crooked, pull loose and re-stick in the proper position. The main purpose of cementing the leathers is to hold them together until they are laced.

Smooth out any wrinkles in the lining by rubbing toward the edge with a bone folder. The bone folder may also be used to press lining into gouges where there will be folds.

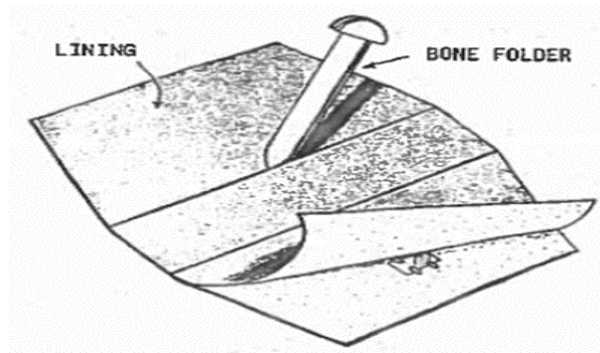

There are times when you will need to shape the lining and leather together over a form. Other times you will need to hold them together on a curve.

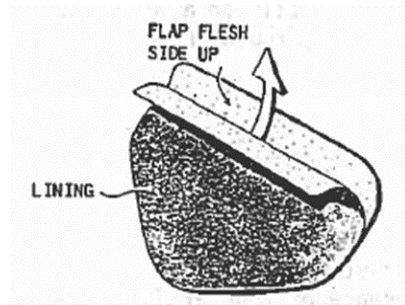

Carefully follow the instructions for each pattern you use. Trim away excess lining which projects beyond the leather.

Caution: Contact cement used for gluing must be used in well ventilated areas. Read the warnings on the can.



Using EcoWeld Water Based Contact Adhesives On Leather <https://www.youtube.com/watch?v=fkNmYoYITqw>

The Leather Element: Leather Glue Overview Learning Leathercraft with Jim Linnell – Lesson 12: Wallet Assembly <https://www.youtube.com/watch?v=lgyeA5u-AB8&list=PL2v0zL3aZty-xboVhml3Z5SKuWkumtzaM&index=13>

Skiving Tools

Using the Skiving Tool

Skiving reduces the thickness of the leather in areas where two or more pieces join or where the leather will be doubled over and cemented to make a facing. Places where skiving would be helpful include a belt end which must attach to a buckle or the edges of a handbag front and gusset which are to be laced together.

Several types of skiving tools are available. Two easy-to-use types are shown. Both use the injector type razor blades. The skiver shown on the left is recommended. It is more durable and easier to adjust and control.

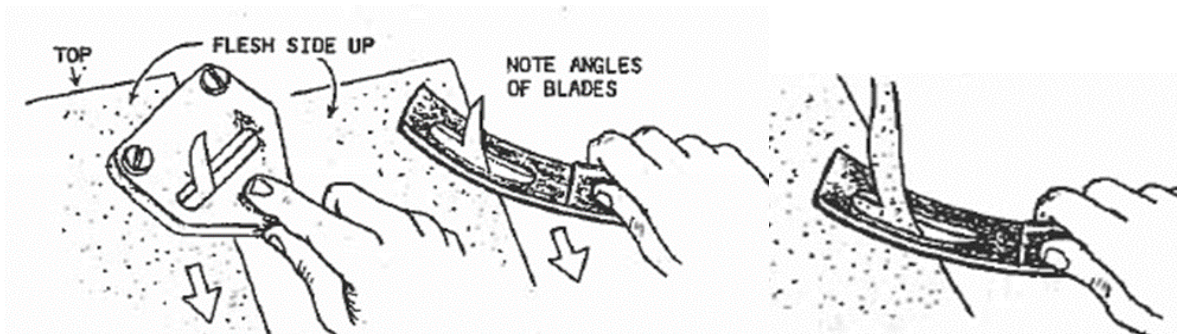

NOTE: Leather should be cased (wetted) before skiving.

Place leather flesh-side-up on the work surface, holding down with the left hand. On light leathers, begin the skive down a bit from the top edge as it will be easier to start. You can begin by placing the skivers at the angles shown, as a slicing action makes skiving easier.

The width of the skive should be at least 3/8" and about half the thickness of the leather should be skived away. If the skived area is not deep enough, or wide enough, simply repeat the process.

Pull the skiver toward you, maintaining constant pressure, angle, and rigid hold on the tool. Uneven skives will occur if you do not have constant pressure. (The tool on the left above can be used by left-handed people.)

It will take some practice to make uniform skives.

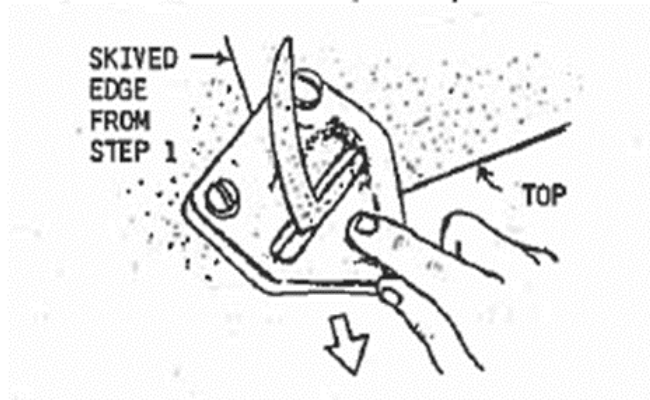

After skiving the full edge, turn the leather and complete the skive to the top on light leathers. Match the angle on the skive already completed.

[How To Use A Safety Beveler On Leather](https://www.youtube.com/watch?v=N7Xsl-lokGw&list=PL330E95D65DA4BA68&index=131)

<https://www.youtube.com/watch?v=N7Xsl-lokGw&list=PL330E95D65DA4BA68&index=131>

Gouging Tools

Using the Gouging Tool

Gouging removes some of the leather from an area. It may be used on a fold line or to form a groove for stitching so it is below the surface and will not wear as rapidly.

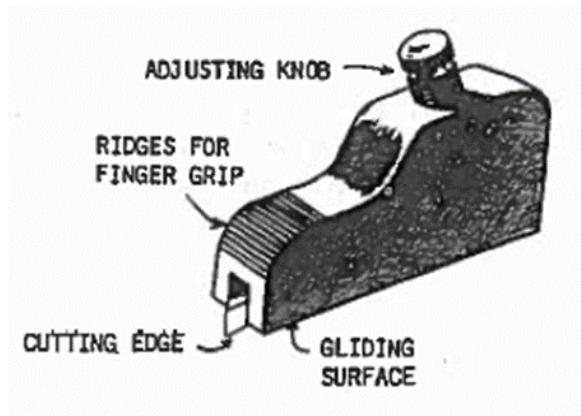

Generally, gouges are made on the flesh side for folding and the grain side for stitching.

The adjustable “V” gouge has an adjusting knob on top that regulates the depth of the gouge. Turning the knob clockwise raises the cutting edge; counterclockwise lowers the cutting edge. Adjust the gouging depth on scrap leather before gouging lines on the project. Gouging depth depends on the purpose for the gouge.

Moistening the leather at the gouge lines often makes gouging easier. Center the cutting edge on the marked gouge line. Use a straight edge as a guide for the gouge so it will move evenly and smoothly along the marked line. The distance from the center of the gouge to the side of the straight edge will determine the position of the edge.

Since the cutting edge is at the extreme end of the tool for maximum visibility, it is usually best to begin the gouging at least 1/2" from the edge. The gliding surface then becomes effective at once and controls the

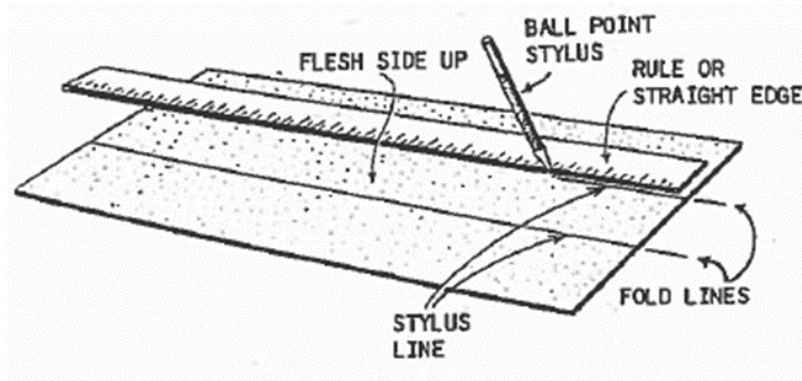
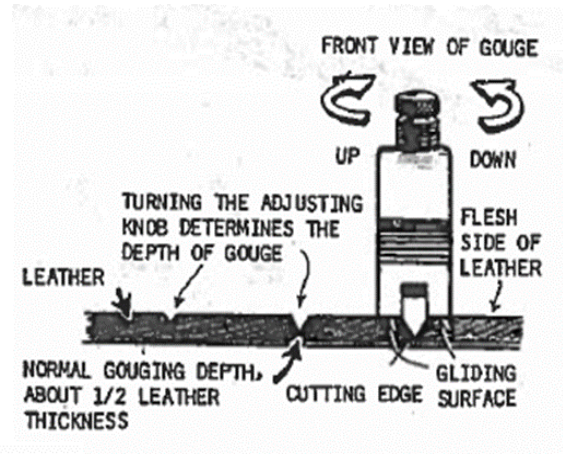

gouging depth. Leather may be turned to complete the gouges.

Start with a shallow gouge and repeat with a deeper setting as often as necessary.

Other types of handheld adjustable round and "V" gouges are available.

The "V" gouge is best for gouging folds. Hold the gouge at approximately a 30-degree angle. Use a ruler or straight edge to keep gouges straight.

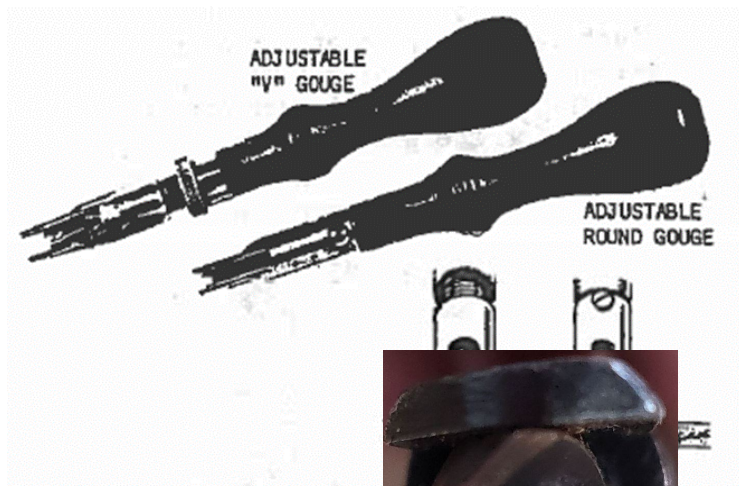

The round gouge is not as good for folds but may be used to carve interior sewing channels or to carve decorative designs.

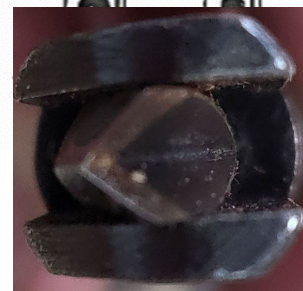

Using Hole Punches

Revolving Punch

The revolving punch is made like pliers but is modified to punch holes in leather. One jaw has a revolving head with round tubes of different diameters projecting from it. The opposing jaw has a small anvil. This design allows you to punch different size holes with one tool.

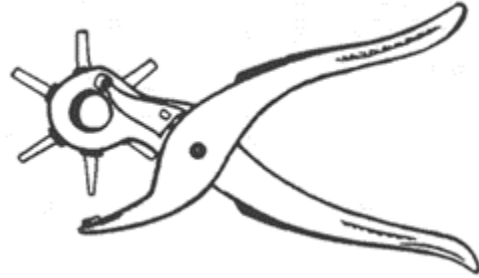

To use, the desired hole size is selected and turned into position, so the proper tube meets the anvil on the opposite jaw. The punch is centered over pre-marked locations on the leather and the handle squeezed firmly.

This is a good tool for punching single holes, one at a time. It is sometimes difficult to punch larger size holes in thick or multiple layers of leather.

If lacing holes are to be punched for 3/32" lace, the #1 size corresponds to 3/32" diameter.

| TUBE SIZES | | | | | |
|------------|--------|--------|--------|--------|--------|
| | | | | | |
| Size 1 | Size 2 | Size 3 | Size 4 | Size 5 | Size 6 |
| 3/32" | 7/64" | 1/8" | 5/32" | 11/64" | 3/16" |

Drive Punch

Drive punches are also used for punching round holes one at a time. These come in various sizes as individual tools or sets. Be sure to place a good cutting surface under the leather before you punch in order to preserve the quality of your punch. Good cutting surface examples include cutting boards, wood, hard rubber mat, or extra layers of leather to punch into.

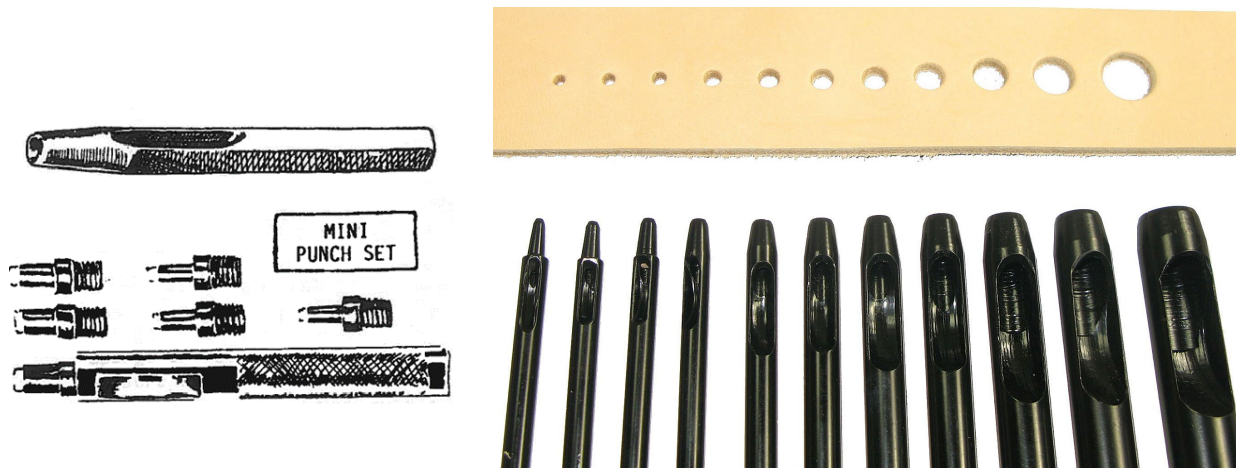

4-IN-1 ROUND HOLE PUNCH

This punch is used in the same way as the multi-prong punches except it punches 1/16 inch round holes instead of slits. It punches the holes more accurately and rapidly than could be accomplished with the single hole punches. Always remember to use a proper cutting & punching surface under your leather to protect your tools.

Scribe a guide line with wing dividers to keep all the holes the same distance from the edge. Insure proper spacing by placing the end tube in the last hole punched.

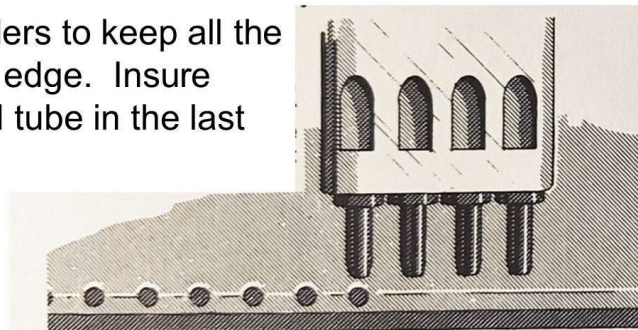

PUNCHING LACING HOLES (Lacing chisels)

Before you can begin lacing, you have to punch precisely spaced lacing holes or slits in the leather. There are several ways to do this and many tools available. Lacing chisels are so called because they look like small chisels. They punch lacing slits instead of round holes.

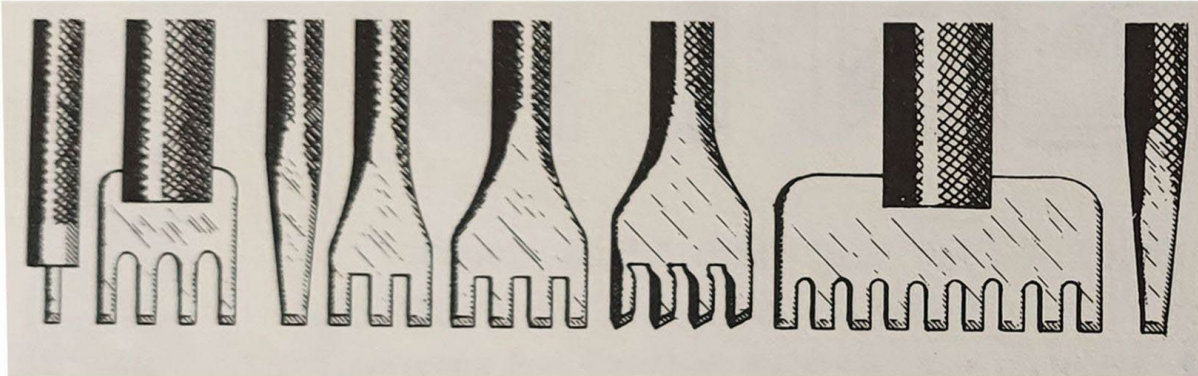

These chisels come in single-prong, three-prong, four-prong, six-prong, and eight-prong punches and they punch slits ranging from 1/16 inch to 5/32 inch in width.

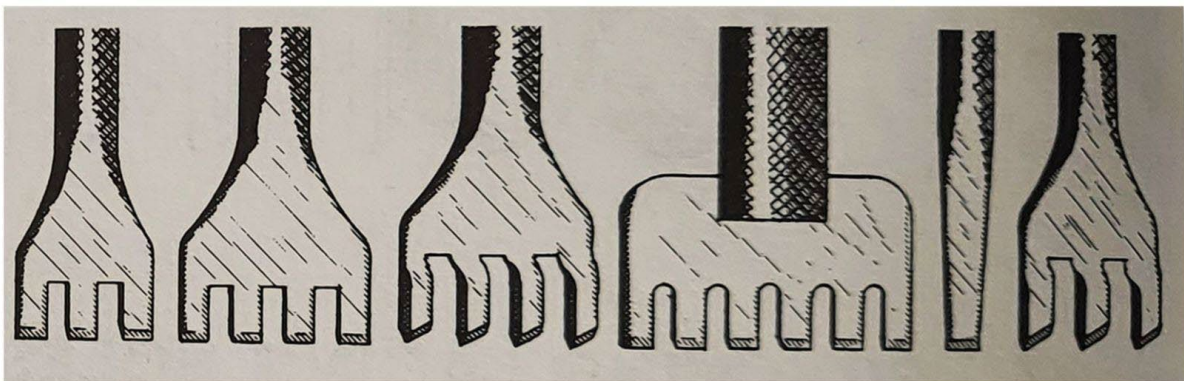

They also come in angled chisels for slanted lacing slits. The 1/16 inch chisels are used for punching saddle stitching slits, to be sewn with thread. The 3/32 inch chisels are for 3/32 inch lace, 1/8 inch for 1/8 inch lace and 5/32 inch for buckstitch or florentine lace.

Chapter 11—Structural Assembly Techniques

Basic Leathercraft Lacing

Lacing puts the finishing touch on handmade leather articles. How good the finished project looks depends very much on the lacing. How you lace and your technique have a great deal of importance in the appearance of the finished project. You can either punch your own holes or you will be using a kit that the holes have already been punched.

Items Needed for Lacing

- Practice pieces of leather
- Lacing and lacing needle
- Tools for measuring, marking and hole punching

Remember: Always lace with the front or outside of the project facing you.

Lacing is special. It will have a smooth side and a rough or flesh side, much as the leather itself does. When you are done lacing a project, only the smooth side should show. You should load two yards of lace in the needle at a time. Working with longer pieces of lacing will be difficult and can cause the lacing to wear and become frayed as it is pulled through the lacing holes.

Kangaroo or calf lacing are the best to use and will come in a variety of colors and earth tones from tan to dark brown and black. Kangaroo lacing is a little stronger than calf lacing. It can be purchased by the yard or by the spool. It is cheaper when you buy it by the spool.

Preparing the Item for Lacing

Either a round hole punch or a lacing chisel (sometimes called a thonging chisel) may be used for punching holes. Some people prefer round holes for some kinds of lacing and slits for other kinds. Holes can be slightly enlarged with a stylus, or the pointed end of a modeling tool, so the lacing needle will slide through more easily.

Scribe a light guideline $1/8$ " from edge around leather item to be laced. Use a ruler and the point of a modeling tool or other methods.



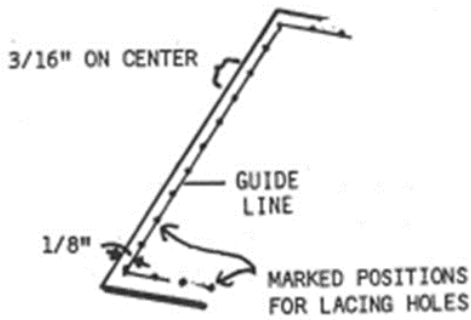

Measure and mark position of lacing holes along the guidelines. You must have an even number of holes for the stitches to come out right if you are doing the running stitch.

Use the type of punch desired to make holes. Carefully follow the marks.

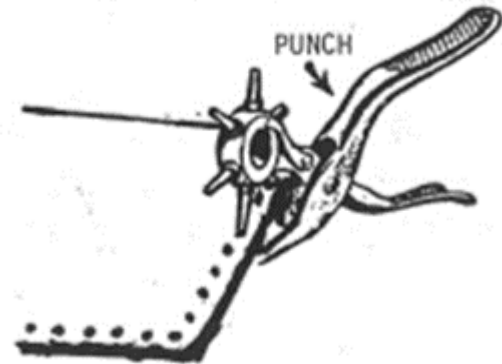

Note: The multiple prong lacing chisel or the 4-in-1 chisel round hole punch provides automatic spacing of lacing holes.

Using Lacing Chisels

Lacing chisels are also called lacing punches. When cutting your own leather articles, you need to punch precisely spaced lacing holes. Information in the next section will tell how to do this.

Lacing chisels (lacing punches) are made single prong and multi-prong. The single prong is used for corner slits and curves. It can also be used in a specific way for the running stitch. The multi-prong is faster and more accurate for straight lines where the whip stitch can be used.

Punching Holes with Lacing Chisel

You will need a piece of soft wood to place under your leather practice piece or article. Place the leather tooled side up. With the point of the modeling tool, mark a light guideline. This line should be $\frac{1}{8}$ inch from the edge of the leather item which is to be laced. Then, with a razor blade or sharp knife, trim sharp corners of the leather item so they are very slightly rounded.

Use a single prong chisel to punch all corner holes. Punch all holes to a uniform depth of the thonging chisel.

Holding the lacing chisel straight up and down, strike firmly and squarely with the mallet. Never use a steel hammer to strike tools.

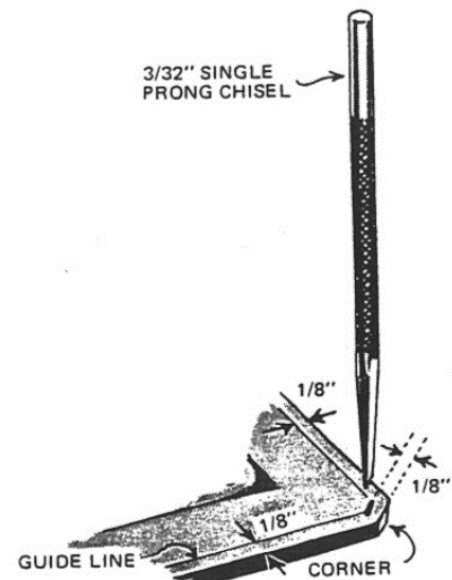

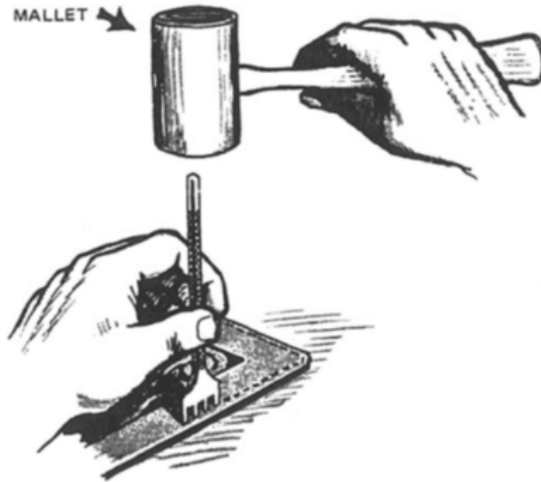

After punching the corner holes, begin next holes with the multi-prong chisel. Space the first hole (from the corner) the same width as the punch blade ($3/32$ ").

To properly align succeeding holes, place the first prong in the last hole and punch again.



Continue punching to the next corner. A carefully drawn guideline will help you keep the holes in a straight line.



If the holes would not be evenly spaced as you near the corner, use the single prong chisel and adjust the spacing. Try to keep the holes as even as possible. Unevenly spaced holes cause unsightly, irregularly laced edges which detract from the appearance of the finished article.

Punching holes in a circle is easily accomplished by using a 3-prong chisel. Following your guideline, punch 3 holes. Then set the first prong of the punch in the last hole.

Punch again. Continue punching until you are finished. Even the spacing for the final holes with a single prong chisel, if necessary.

The same technique is used with the 4-in-1 round hole punch.

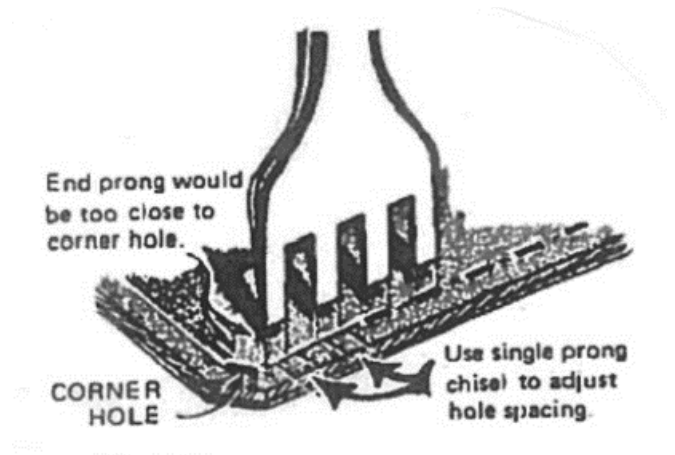

Note: If the lacing chisel is used for punching holes for the running stitch, the single prong punch should be used, and holes turned 90° degrees to edge as shown below.

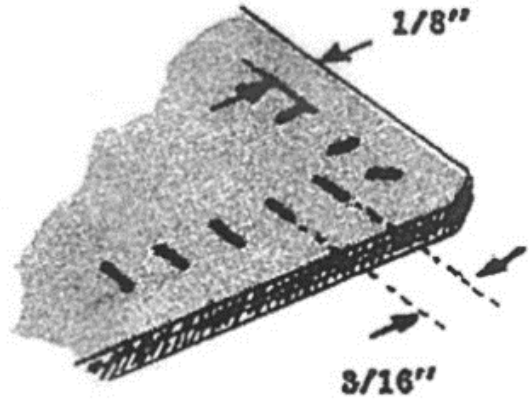

Measuring Lace

The most common lacing used is 3/32 of an inch in width, though other popular widths are 1/8 and 3/16. Lacing will slide through the holes more easily if it is first treated with beeswax or other leather preservative to make it more slippery.

| Style | Edge Distance | Amount Required |
|-----------------------|---------------|-----------------|
| Running Stitch Lacing | 1/8 inch | 1 ½ x distance |
| Whip Stitch Lacing | 1/8 inch | 4 x distance |

Shown below are a variety of some lacing styles that have been popular over the years. Shown also is the approximate length of lace you will need for each. This is calculated by using a multiplier times the length you are lacing. Example: A 9" x 3 ½" billfold has a total length to be laced of 25". The double cordovan stitch takes seven times the total or 25" times 7 or 175", which is about five yards of lace.

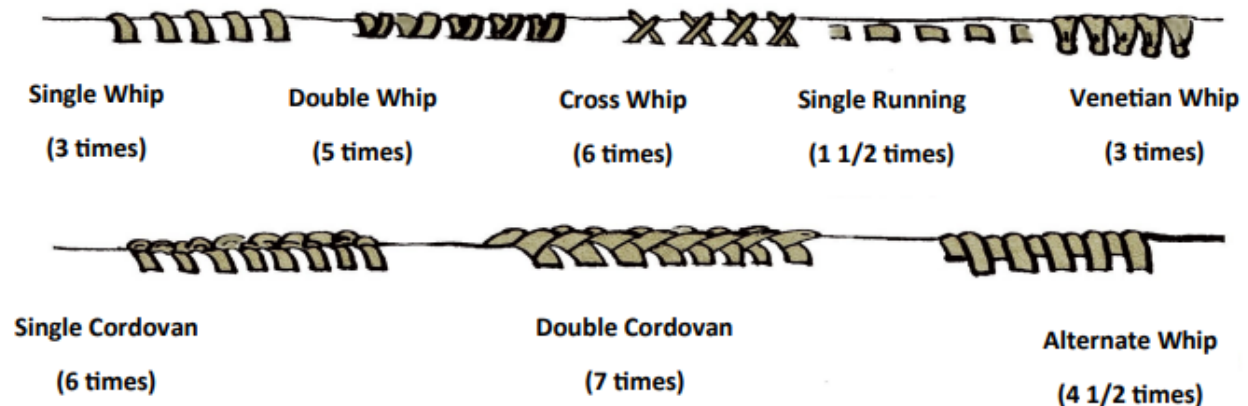

How to Lace

The main reason for lacing is to attach two or more pieces of leather together. It is also used to give a decorative effect.

When lacing, always lace with the front or finished side of the article facing you. It is suggested that you go left to right. Left-handed leathercrafters will have to experiment to find the best method for them which gives satisfactory results.

Two-Prong Lacing Needle

Load two yards of lacing in the lacing needle at one time. Working with longer pieces of lacing will be difficult and can cause the lacing to wear and become frayed as it is pulled through the lacing holes.

Skive (cut off in thin layers) one end of lace with a sharp knife.

Point the skived end as shown:

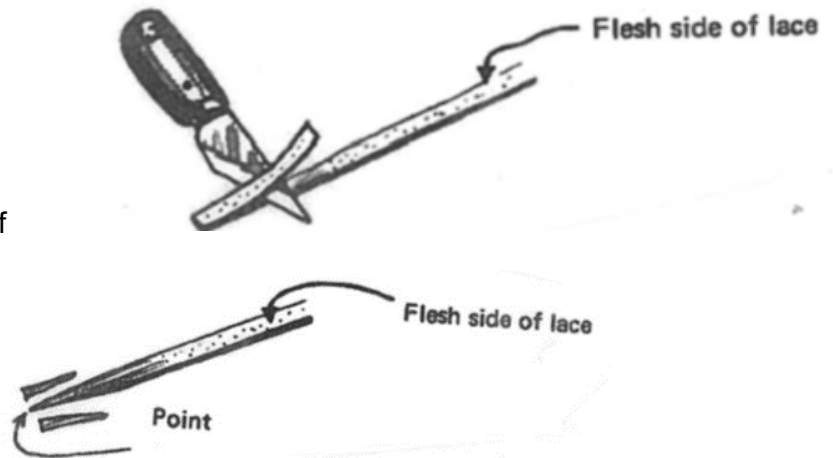

Spring the threading end of the needle open. A thin bladed knife can be used. (You may want to have an adult help with this).



Insert pointed end of lace into the needle, smooth side against prongs.

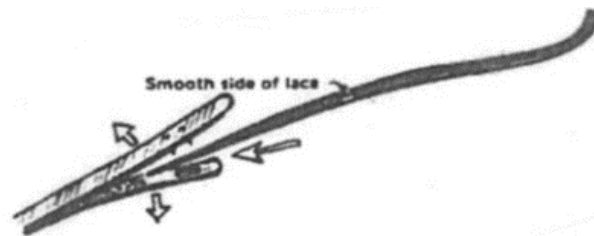

Close the needle on lace and tap lightly with a mallet, or a small pair of pliers, so that prongs pierce the lace and lock it in place. The needle can be unlocked with the edge of a thin bladed knife.

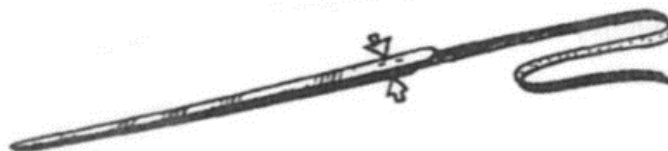

The Life-Eye Lacing Needle

There are solid brass round needles, much preferred by professional craftsmen. Life-eye needles can be used again and again as their name implies. The small size is recommended for 3/32-inch and 1/8-inch laces. The large size, called the Latigo Life-Eye, is used for larger laces, such as 3/16-inch, Florentine, and 5/32-inch buck stitch, and even latigo laces.

Cut the lacing to a sharp point, but do not skive.

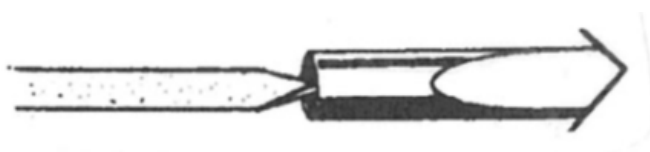

clockwise

Insert pointed end of lace in the needle eye and twist several times until the lace is secured firmly.

To remove lacing from the needle eye, twist lace counterclockwise. Should the needle fail to thread properly, there is probably material lodged in the eye. This can be removed with a pin. If lacing accidentally breaks even with the eye of this needle, unscrew stub with a pair of small tweezers. If this is unsuccessful, take a pin and run it into the stub of lace (at an angle) and unscrew counterclockwise.

QUICK TIPS

TIP: If lace is stuck inside the life-eye needle, do not dig out. This destroys the threads. Have an adult help you and carefully heat the needle with a flame so the lace will be released.

Types of Lacing

The main reason for lacing is to attach two or more pieces of leather together. It is also used to give a decorative effect.

When lacing, always lace with the front or finished side of the article facing you. It is suggested that you go left to right. Left-handed leathercrafters will have to experiment to find the best method for them which gives satisfactory results.

Whip Stitch Lacing (Single thickness of leather)



1. Begin lacing as shown below. Leave about $\frac{1}{2}$ " of lace at the end. Lace around the edge through each hole keeping the smooth side of lacing down.



2. Continue lacing, pulling the stitches tight as you go. Do not allow lacing to twist.

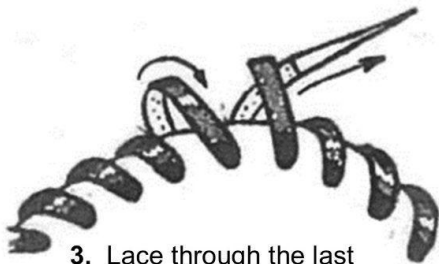

3. Lace through the last hole. Leave this loop loose.



4. Lace through the beginning hole, under the end of lace. Leave this loop loose.

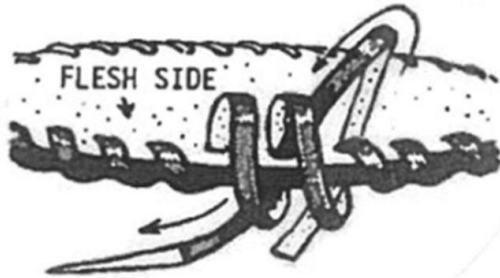

5. Turn leather so the flesh side is up. Push needle through hole of previous loosened stitch. Be sure the needle goes on inside of lace.

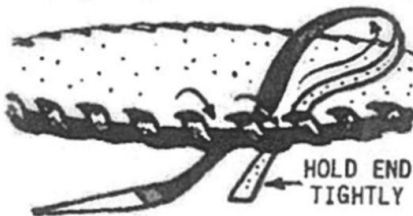

6. Pull the two loose loops tight. Hold the end from slipping.



Turn the leather to the carved side. Carefully cut off lace ends with the point of a sharp knife. Tap lacing flat with mallet.

THE WHIPSTITCH (Double thickness of leather)

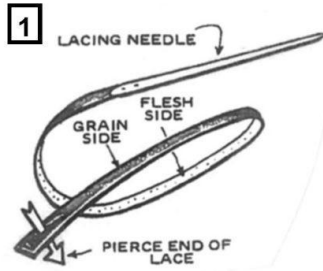

1. Thread the needle and then pierce the opposite end of the lace with a sharp knife leaving a slit of 1/8 inch.

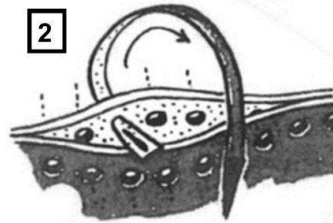

2. Begin lacing in between the two layers of leather. Leave about 1/4 inch to 1/2 inch at the end where you slit the lace.

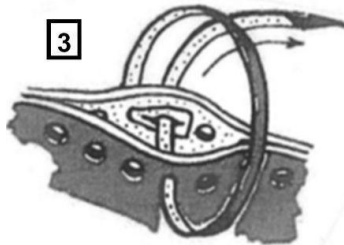

3. Push the needle through the second hole, and then thread it through the slit in the end of lace and through the opposite hole.

Pull the first loop tight over the end of the lace. Pull the stitch up snug, but not too tight, which can break the lace. Continue lacing, tightening the lace as you go.

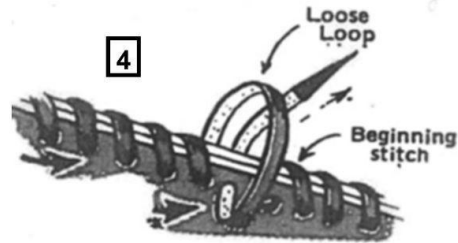

4. Lace around the article, leaving a loose loop in the second hole from the beginning stitch. There will be one unlaced hole between your very first and the last stitch shown.

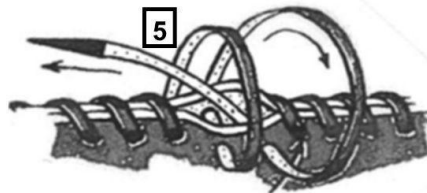

5. Spread the two leather layers and lace through the last hole, up between the leathers and through the first loose loop.



6. Pull the end of the lace tight to take slack out of the last loop.

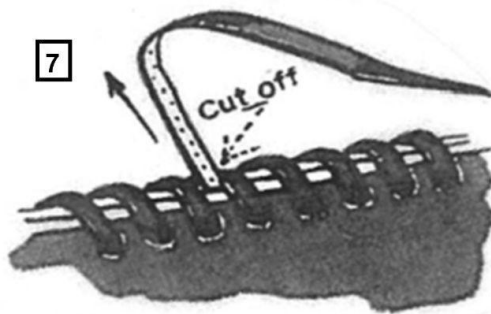

7. Cut off the end of the lace with a sharp knife and tap all lacing flat with a smooth-faced mallet.

When **Whip Stitching on a single thickness of leather**, be sure to catch the beginning tail of lace under the next few stitches on the back of the leather. End by running the needle back under the last few stitches on the back of the leather.

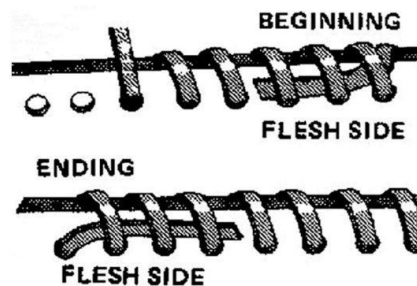

Running Stitch Lacing

Thread the needle, then pierce the opposite end of the lace with a sharp knife, leaving a 1/8" slit.

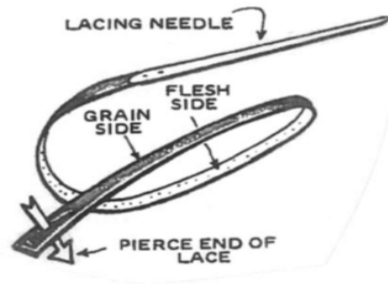

Push the lace through the hole from the flesh side.

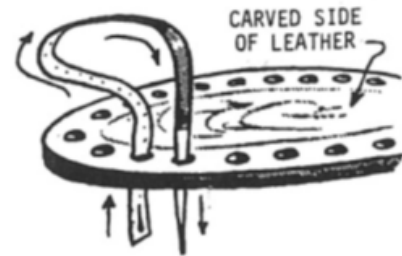

Run the needle through the slit in the lace and up through the next hole.

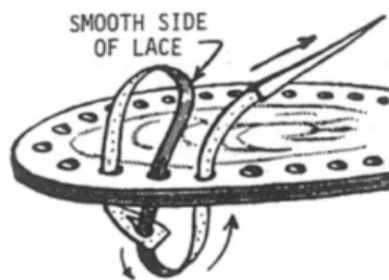

Pull the lace tight to lock the end. Continue lacing over and under through holes.

Lace completely around the article. Pull stitches tight as you go and lace through the last hole.

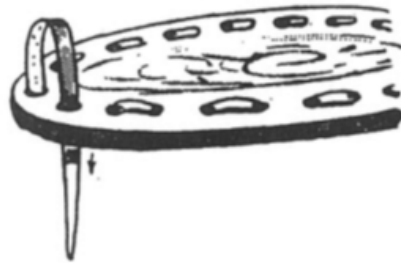

Push the needle under the last stitch on the flesh side and pull tight.

Pull the end of the lace up tight. Carefully cut off the end with the point of a sharp knife. Tap lacing flat with mallet.

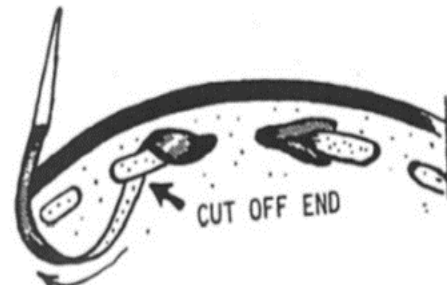

NOTE: When lacing only one thickness of leather, glue ends to the back of the article.

BUCKSTITCHING

What we term "BUCKSTITCHING" probably derived from the early days when leather garments and other items were sewn together with buckskin thongs. These laces were made from deer skins, either rawhide or with some tannage. Deer skin is very strong, therefore articles sewn or laced with deerskin thongs, or lace, were very durable. Laces and thongs made of deerskin used to be commercially available. There still may be a few places or people who prepare these laces, but generally speaking they are probably not to readily available.

Almost any kind of commercial lace leather can be used for buckstitching. Or, you can make your own. For best results, the edges of the leather would be beveled on the flesh side. This allows the stitches to lay flatter against the leather...which is more practical and more pleasing in appearance. Each stitch should be made as uniform as possible...the most desirable being in a diamond shape. This can only be accomplished by slitting the leather with lacing punches or saddler's awls of the proper size. **Round punches are not used for buckstitching as a diamond shaped stitch cannot be made.**

"BUCKSTITCHING" is simply a running (over-under) stitch, with the lace coming up through one slit and down through the next...continuing in this manner until the stitching has been completed. Buckstitching, as we know it today, is generally used as a decoration to enhance the appearance of the design or project. It should not be used as a sole agent to hold two or more pieces of leather together where great stress and strain will be applied to the buckstitched seams. Generally, these seams are sewn by hand (or machine) as the leather buckstitching cannot bear the strain of constant use. In this case, buckstitching should be used as a decoration only.

There are "rights" and "wrongs" with BUCKSTITCHING as with anything else. REMEMBER...the proper angle of your lacing slits is most important for good diamond shaped stitches. **Note-You will need an even number of holes around your project so the last hole ends with the lace ending on the under side of the leather.**

Examples here illustrate the diamond shaped stitches created by using a variety of punches, spacers, and laces. Scribe light guide lines with wing dividers for each punch and lace as shown. Study the examples shown.

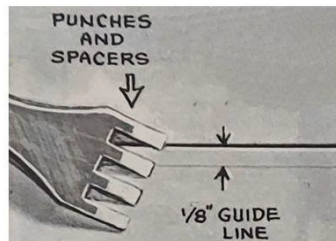

3/32 inch
4-prong
lacing
chisel



BUCKSTITCHING (continued)

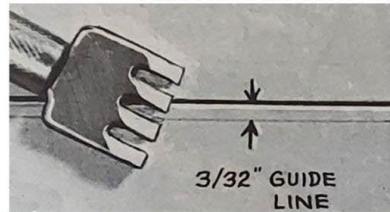

3/32"
4-prong
angle
lacing chisel



WITH THE ANGLED SLITS THE DIAMONDS ARE LESS ELONGATED. ROUGH (FLESH SIDE) OF LACE WILL APPEAR ON THE BACK SIDE OF THE PROJECT.

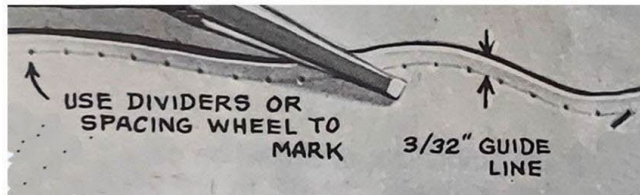

3/32"
single-prong
lacing chisel



FOR 3/32" LACE USE No. 6 OR No. 7 WHEEL.

FOR 1/8" LACE USE No. 5 OR No. 6 WHEEL AND 1/8" SINGLE PRONG CHISEL.

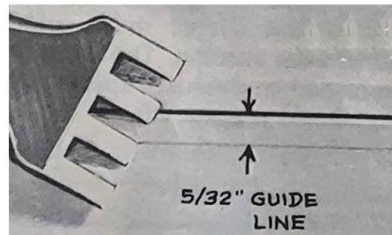

1/8"
4-prong
lacing chisel

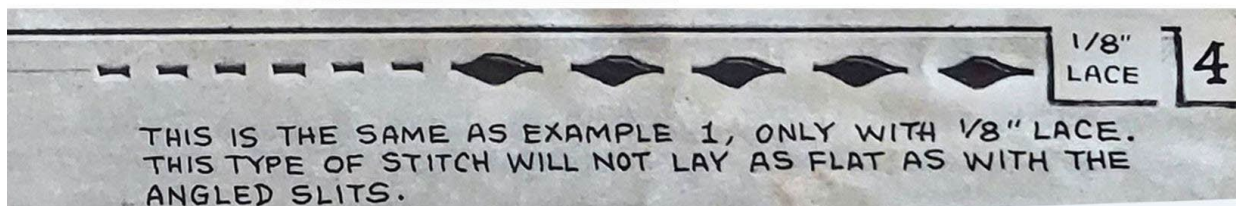

THIS IS THE SAME AS EXAMPLE 1, ONLY WITH 1/8" LACE. THIS TYPE OF STITCH WILL NOT LAY AS FLAT AS WITH THE ANGLED SLITS.

BUCKSTITCHING (continued)

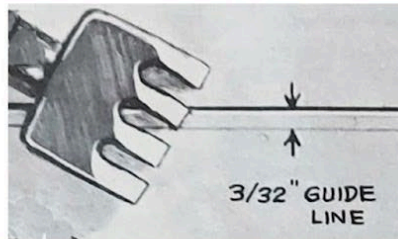

1/8"
4-prong
angle
lacing chisel

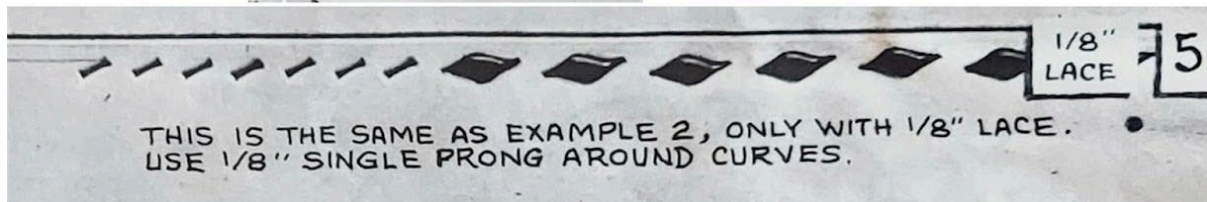

THIS IS THE SAME AS EXAMPLE 2, ONLY WITH 1/8" LACE. USE 1/8" SINGLE PRONG AROUND CURVES.



5/32"
Single prong
lacing chisel

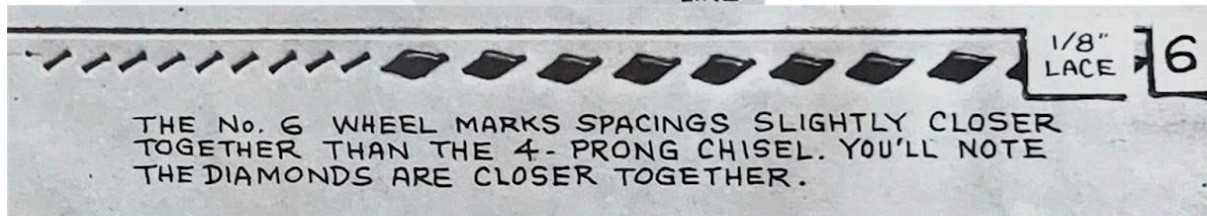

THE No. 6 WHEEL MARKS SPACINGS SLIGHTLY CLOSER TOGETHER THAN THE 4-PRONG CHISEL. YOU'LL NOTE THE DIAMONDS ARE CLOSER TOGETHER.

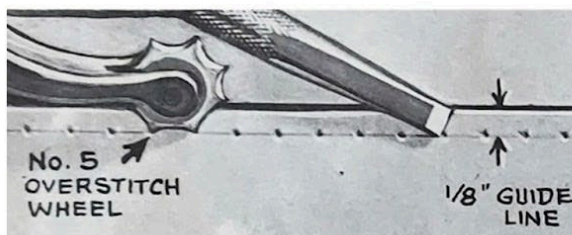

5/32"
Single prong
lacing chisel

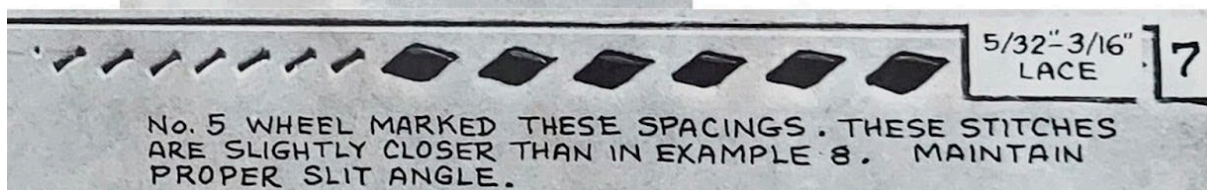

No. 5 WHEEL MARKED THESE SPACINGS. THESE STITCHES ARE SLIGHTLY CLOSER THAN IN EXAMPLE 8. MAINTAIN PROPER SLIT ANGLE.

Leather Lacing Techniques Video

<https://www.youtube.com/watch?v=hJtbthWGn3U&list=PL2v0zL3aZty-RPep7sBL6AB6gquOi3ZZ4&index=4>

Beginning and ending for Buckstitch

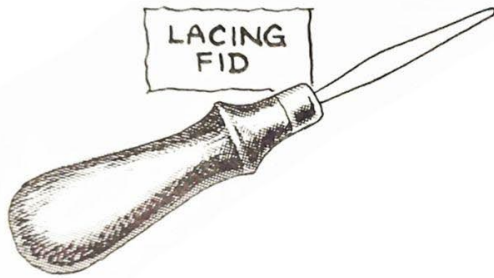

The **LACING FID** is a most important tool to aid in buckstitching through the slits made by the lacing chisels. The end of the tool is smooth-blunted for easy opening of the slits. This makes insertion of the needle and/or lace easier...especially from the back side.

Preparing the project for buckstitching

Before punching the lacing slits, always “count” the number of marks around the project after marking with the wheel, or chisels. **An even number is desired**, so you will have an over-under set of stitches on the front of your project. **Abutted stitches (stitches right next to each other) are not desirable.** Always **adjust** odd numbered marks so you have an even number of marks around the project, from start to end.



On a large project, where it would be difficult to count all the marks, punch the holes from the beginning to about 5 inches before the end. Start lacing and lace up to where you stopped punching holes about 5 inches before the end. In that last 5 inches, mark the holes carefully to see if it will come out right. If you have to fit an extra hole to make it come out right you have some space to either spread the holes out a little or crowd the holes together a little. Use good judgement. Farther apart is better than too close together.

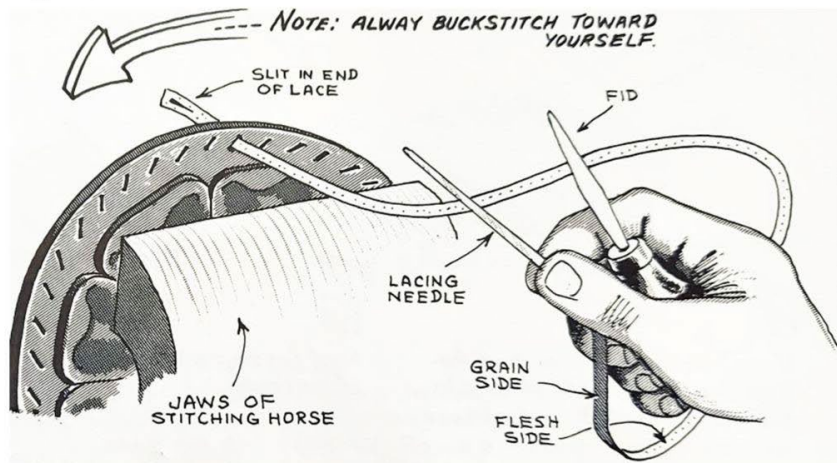

Buckstitching on one thickness (coaster)

Push fid in slit to stretch the hole, pull lace through, from the back side. Put a slit in the end of the lace.

Beginning and ending for Buckstitch (continued)

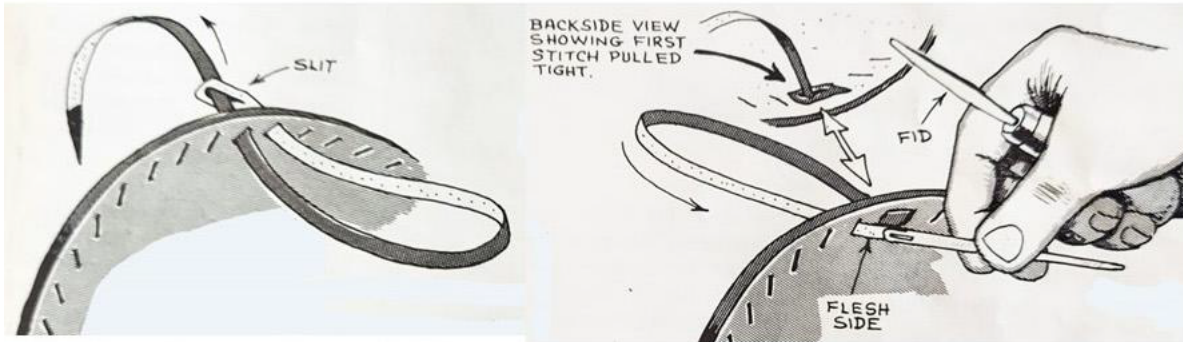

Push lace through second slit...and through the slit in the end of the lace as shown. This will lock the end of the lace when the first stitch is tight.

Pull slitted end of lace up snug, at back, and pull first stitch tight. Open 3rd slit with fid and push needle through from back side. Pull stitch up snug. Continue lacing until there is just 2 slits left.

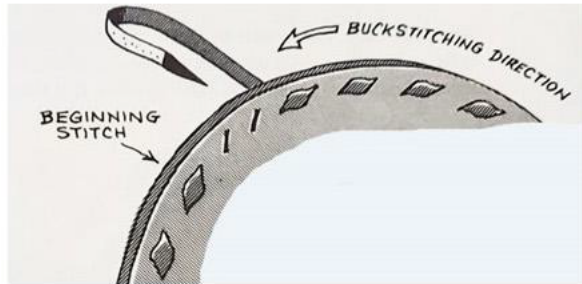

To finish it off......push lace through from back leaving loose loop A. **(see figure 1 below)** Continue lacing, as shown leaving loose loops at (B) and (C). Run end (D) UP through (A).

(see figure 2 below) Smooth side of End (D) should be against the back of coaster. (A) pull tight.

(see figure 3 below) Pull on loop (C) to tighten loop (B) ... pull tight. Next pull end (D) to tighten loop ©.

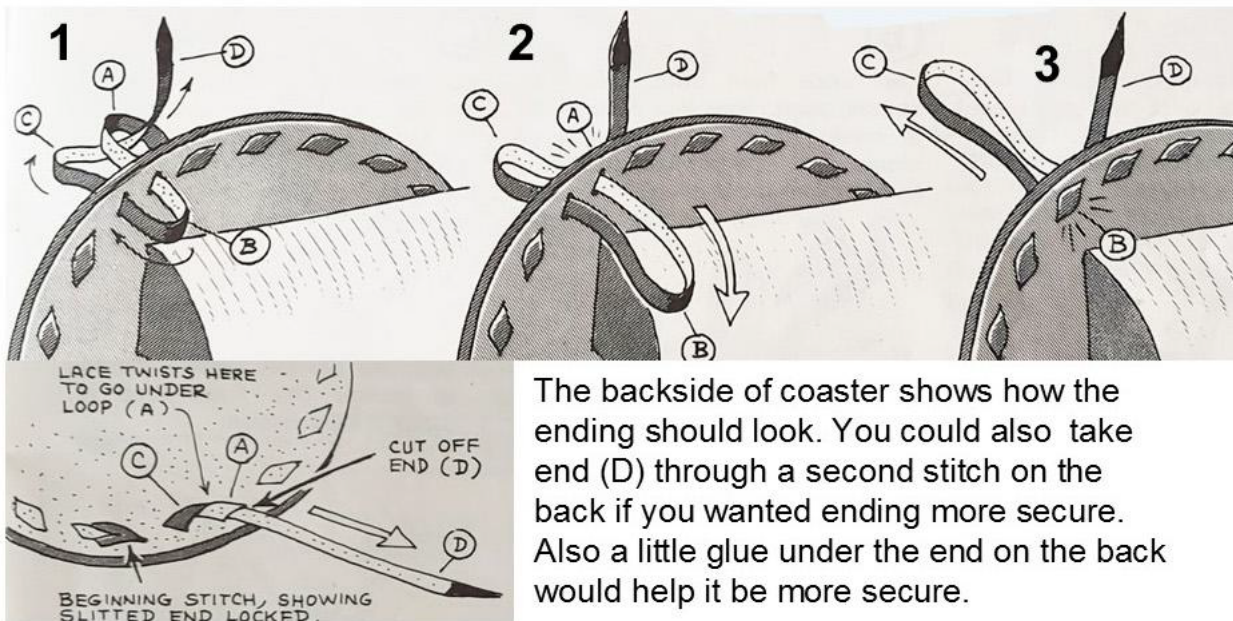

The backside of coaster shows how the ending should look. You could also take end (D) through a second stitch on the back if you wanted ending more secure. Also a little glue under the end on the back would help it be more secure.

Single Loop Lacing (Also called Single Cordovan or Single Buttonhole Stitch)

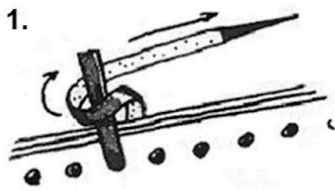

1. Begin at the top of the article. Push lace through the front side. Leave about 1/2" at the end. The front side of the article

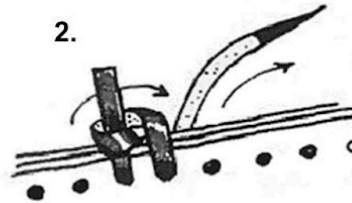

2. Fold end up and loop lace around as shown. Hold with fingers until the first stitch is tightened.



3. Lace through the second hole. Be sure the smooth side of lace faces you. Pull up snugly.

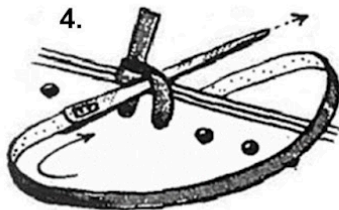

4. Push needle under lace as shown, with the flesh side up. Do not twist lace. Pull up snugly.



5. The first two stitches should be snug, but not tight. They will need to be adjusted when you get completely around the article. Continue lacing in this way until you reach a corner hole.

More stitches are required at corners for the lacing to lie flat and go around the corner.

Lace through corner hole or holes more than once, as shown. Other methods for lacing corners are also permissible. **All corners must be done consistently.**



This method has three stitches through the corner hole. Each stitch is through the hole and then under the loop. The corner hole may need to be enlarged or stretched to fit the extra stitches.

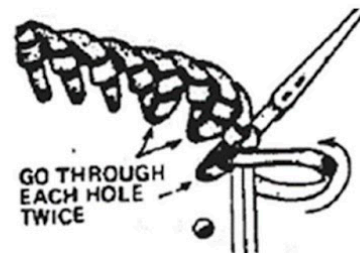

GO THROUGH EACH HOLE TWICE

This method has two stitches going through the three corner holes going around corner.

Continue lacing to the beginning point.



Joining the single loop lace ending to the beginning point to complete lace.

Lace through the last hole and under loop.

Insert stylus end of modeling tool under beginning end of lace.

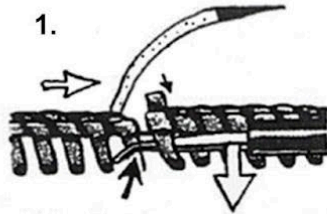

Pull end of lace out of loop with end of modeling tool. Maintain the loose loop.

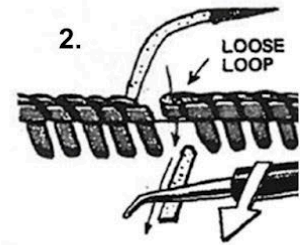

Insert stylus between the leathers and hook it over the end of the lace.

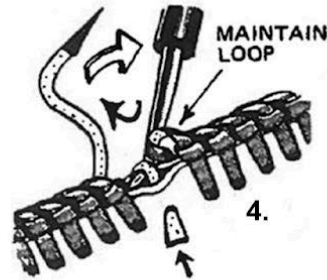
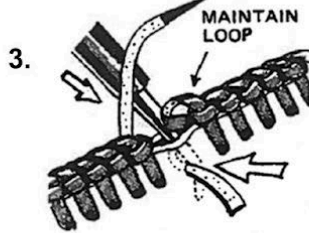

Carefully pull up the stylus and gradually pull the end of the lace out of the hole, up between leathers.

Carefully push the needle down through the loose loop.

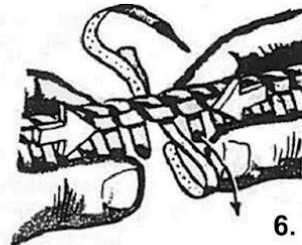
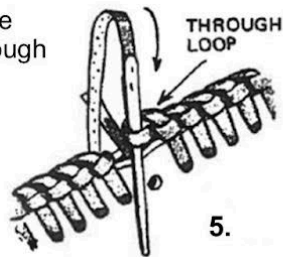

Push the needle through the hole and up between the leathers. Be sure lacing does not twist.

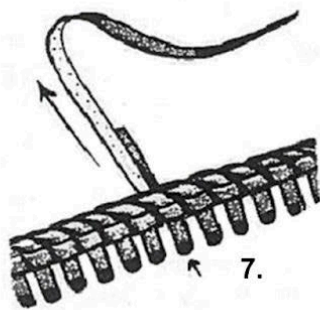

Pull lacing up snug and adjust so all the stitches appear even.

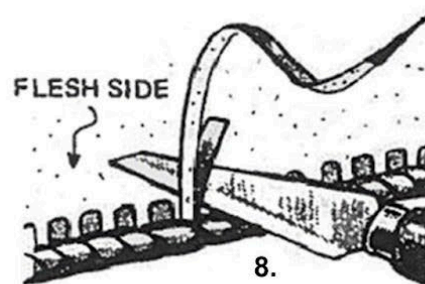

Carefully cut off ends from the flesh side.

(Before you cut the lace you can also apply a little leather glue (that dries clear) on the end of the lace to keep the lace ends from pulling loose & then cut the lace)

Tap lacing flat with a smooth mallet or roll under a wooden dowel.

NOTE: When lacing only one thickness of leather, glue ends to the back of the article.

Single loop lacing is best suited for lacing the edges of the lightweight leathers or a single thickness of leather.



TIP: To make lace slide through holes more easily:

1. Put the end of the stylus through each hole to enlarge it slightly.
2. Coat the lace with leather cream or beeswax to lubricate it. Rub it in well. This also helps preserve the lace.

Double Loop Lacing

(Also called Double Cordovan or Double Buttonhole Stitch.)

Double loop lacing covers a wider area and is used on heavier leather than single loop lacing. It is used especially where two thicknesses of leather require more lacing to cover the edge. On special articles where variations of thickness of leathers occur, the lacing can be joined continuously from one kind of stitch to another. The stitching can also be reversed as thicknesses of leathers decrease.

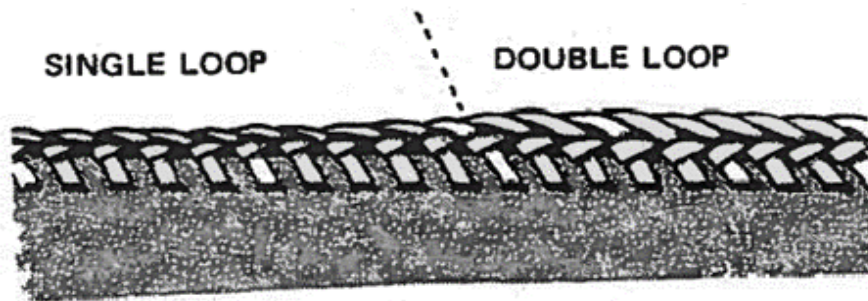

Use the following formula to determine the amount of lacing you will need for the double loop stitch.

| Style | Edge Distance | Amount Required |
|-------------|---------------|----------------------------------|
| Double Loop | 1/8" | 7 1/2 x the distance to be laced |
| | 3/16" | 8 1/2 x distance to be laced |
| | 1/4" | 9 x distance to be laced |

Add 10 percent to the above formulas for splicing and ending lacing.

The front side of the article must face the person lacing beginning with the flesh side of the lace up, pull the needle and lace through the first hole. Leave about 3/4" of the lacing end and go on to lace the next hole.

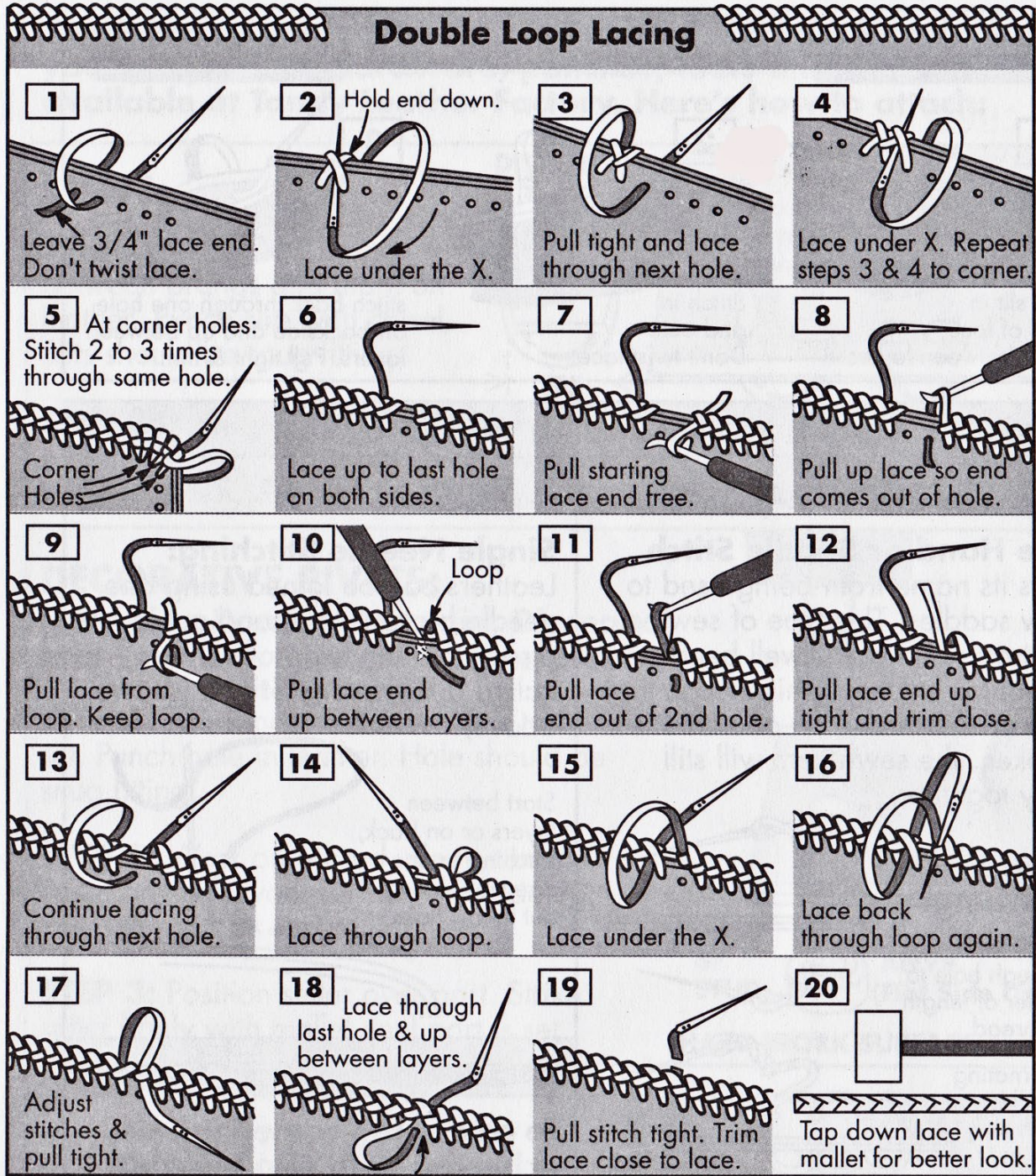

Learning Leathercraft with Jim Linnell – Lesson 13: Double Loop Lacing
<https://www.youtube.com/watch?v=HlpanSwuy4o&list=PL2v0zL3aZty-xboVhml3Z5SKuWkumtzaM> &index=14

SPLICING LACE

When you lace a project it is generally recommended that you use no more than 2 yards of lace at a time. This is because pulling the lace through all those holes wears the lace and may weaken it. It also frays the edges so that the lace doesn't look good toward the end of the project. Well, unless your project is very small and you are doing a very simple stitch, 2 yards of lace will not go completely around it. You will have to splice in a new length of lace, maybe even several times.

The two most common ways to splice lace

A cement splice (sometimes called a "wet" splice) is a splice that is glued together with a leather cement that dries clear. It needs to be clear so it will not show a glue color around the splice.

A dry splice is a way of splicing when lacing two or more thicknesses of leather with single or double loop lacing.

CEMENT SPLICING

This method is commonly used by leathercrafters and manufacturers of lace as well. Often on a spool of lace a piece will be spliced in to fill the spool. Splice when 5 inches of old lace remains.

Skive the end of the old lace on the top side. Skive the end of the new lace on the bottom side. Carefully apply leather cement that dries clear, to the skived ends.

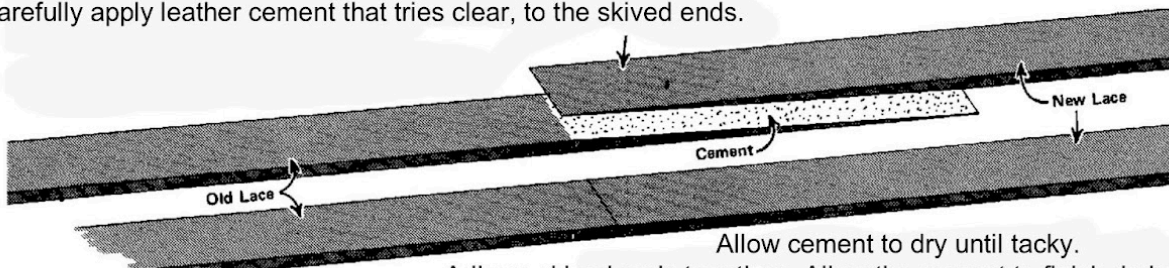

Allow cement to dry until tacky.

Adhere skived ends together. Allow the cement to finish drying.

Continue lacing around your project with new lace. NOTE: It might be helpful to stretch the holes a little with a stylus, lacing fid or tracing tool and be a little gentle pulling the spliced lace through the next few holes.

HOW TO ADD LACE ("Dry Splicing")

When only 5" of old lace remain, stop and attach new lace to a new needle.

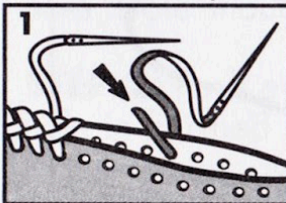

1 Insert new needle. Lace down between parts, 4 holes from last stitch. Stitch out the back. Leave 3/4" lace between parts.

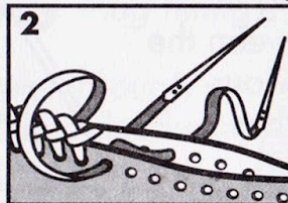

2 Tuck 3/4" lace end between parts. Continue lacing with old needle, securing end of new lace so it won't show.

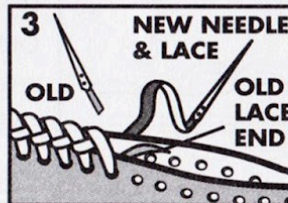

3 Lace through hole across from new lace. Bring lace up between parts. Cut off old lace at angle; leave 1/2" end between parts.

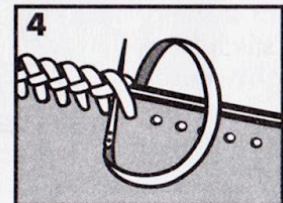

4 Continue lacing with new needle & lace, securing end of old lace under next stitches so the end won't show.

Hand and Saddle Stitching

For the saddle stitch, two harness needles are required and one length of thread as long as your extended arms.

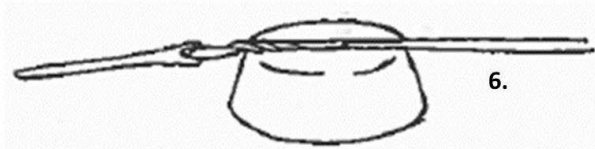
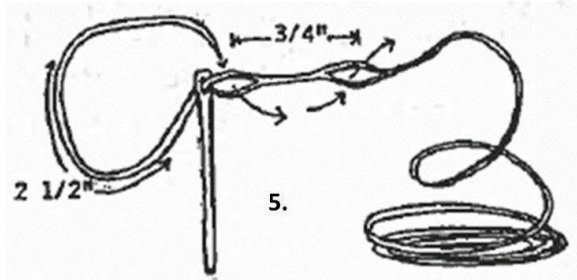

Place one end of the thread through the eye of the needle. Twist the thread open near the eye and pass the short end through the opening. Twist open again about $\frac{3}{4}$ inch further down and pass the end through again. This will lock the thread in place. Repeat for the other needle on the opposite end of the thread.

Pull thread over beeswax several times to fuse thread together.

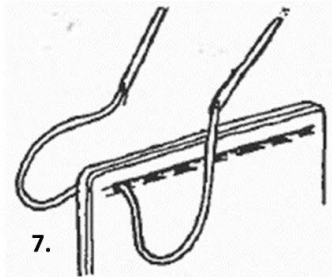

Start by placing a needle through the first hole. Even up the ends of the thread. Push one needle through the second hole.

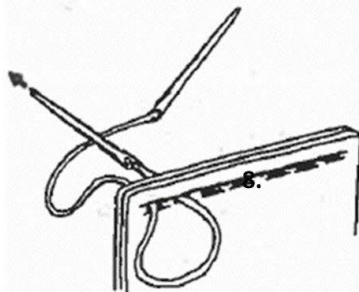

Push one needle through the second hole.

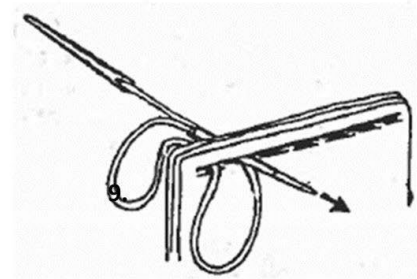

Push the other needle through the same hole. Grasp thread on each side and pull tightly.

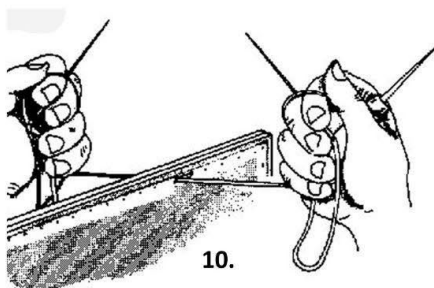

To tighten the stitch grip threads as shown and pull into gouged channel. Use equal tension with both hands. Continue stitching around project to starting hole.

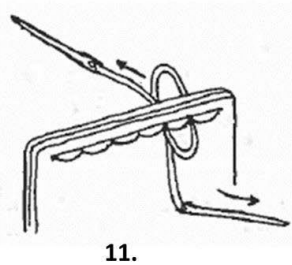

To end, back stitch through two holes.

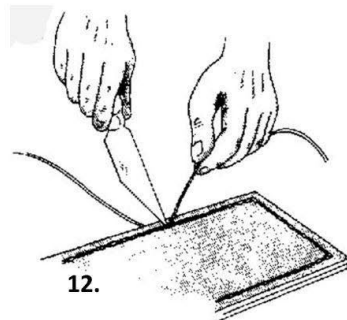

Cut threads off flush with the leather in stitching channel on both sides with a sharp knife.

Splicing thread: If you are sewing and use up a full length of thread and have not reached the starting hole you need to add more thread to finish.

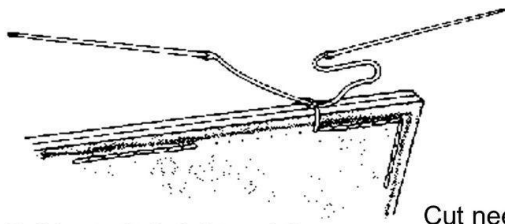

Pull last stitch tight and tie threads together on top edge of leather as shown.

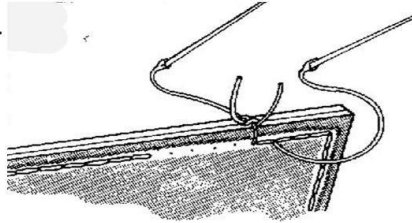

Cut needles off threads. Put needles on a new length of thread. Insert needle one hole back from last stitch and start new thread in this hole. Continue stitching around project to starting hole.

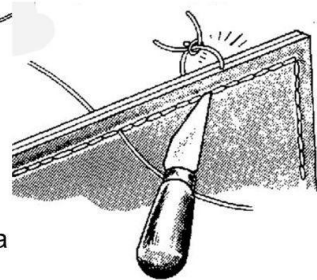

Complete stitching, back stitch two stitches, then cut off both sets of ends.

Finishing touches for the sewing and edges.

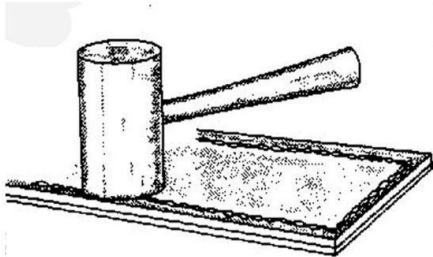

Lay project on smooth work surface and tap over all stitching with a smooth faced mallet. Be careful not to mar leather. This helps set the stitches and smooths them.

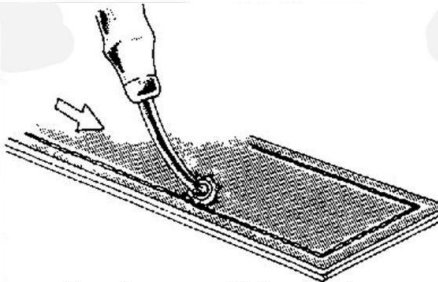

Run the over stitch wheel over all of the stitches. This actually helps the appearance of any slightly irregular stitches.

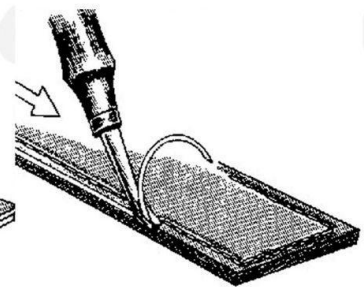

Round the edges of the leather on both sides with an edger.

Optional Hand Stitching



Single Needle Stitching: Leathers can be joined using one needle by sewing in and out in one direction, then tying off. This is called a **Running Stitch** (shown above).

Start between layers or on back, stitching in one direction in and out to last hole.

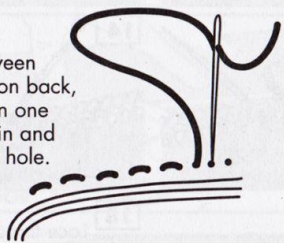

A method similar to the saddle stitching is sometimes used in place of lacing. This method is identical to saddle stitching except that the stitching is generally done with regularly punched holes instead of through diamond holes. Usually a prepared thread (waxed thread) and a tapestry needle are used. Many leathercraft pre-cut and pre-punched kits have this stitching as an option.

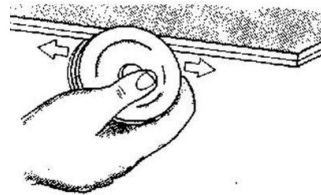

Moisten the edges of the leather and burnish with a circle edge slicker.

To create the same look as achieved with two needles:

Turn and stitch back through the same holes, filling in between the previous stitches.

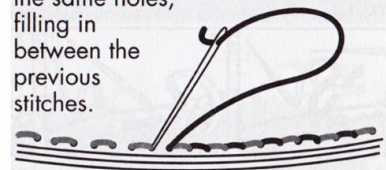

Hand Sewing

Hand sewing is done where high-quality work is desired and in places which are impossible to reach with a sewing machine. A lacing pony or stitching horse may be used to hold the leather in place. This frees both of your hands for the stitching. Select a good resource book and follow the instructions for preparing your thread and threading the needle.

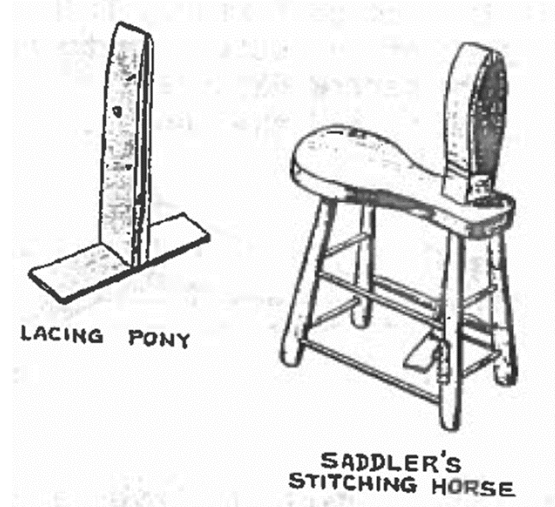

The basic hand stitch is done by starting with a thread two arm's length (about 8 to 10 feet) long and putting a needle on each end.

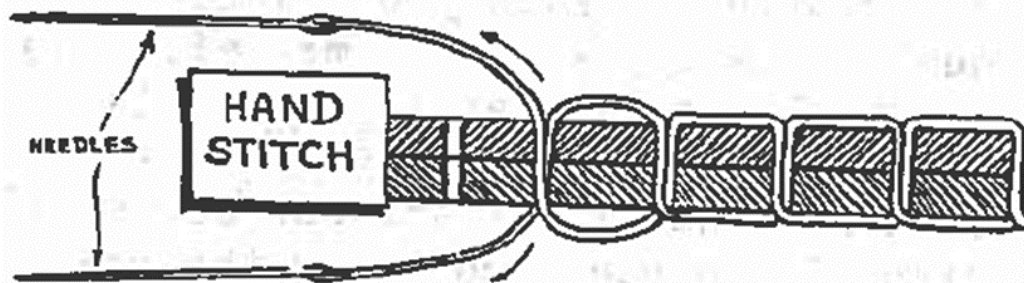

A block of wood should be used to hold the leather straight when you are making a mitered corner.

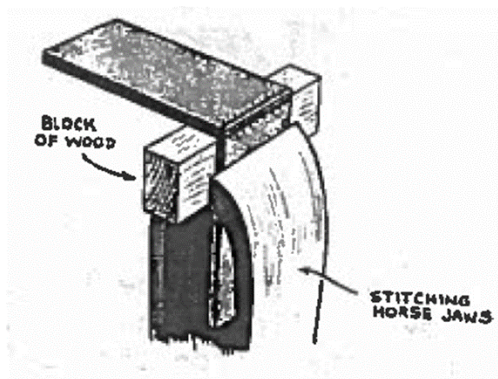

Hand shoe tacks may be used to hold the leather in place when you are sewing leather around a wooden frame.

Curved awls and needles may be needed for some rounded articles.

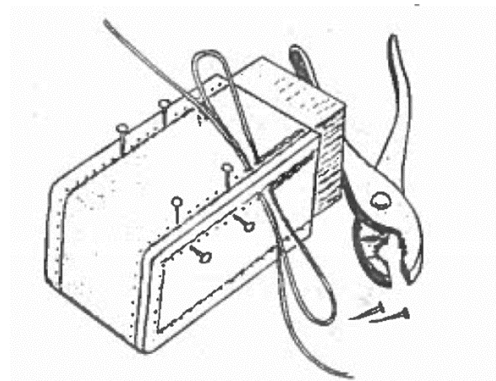

And different stitches, such as the baseball stitch are sometimes most appropriate for an article.

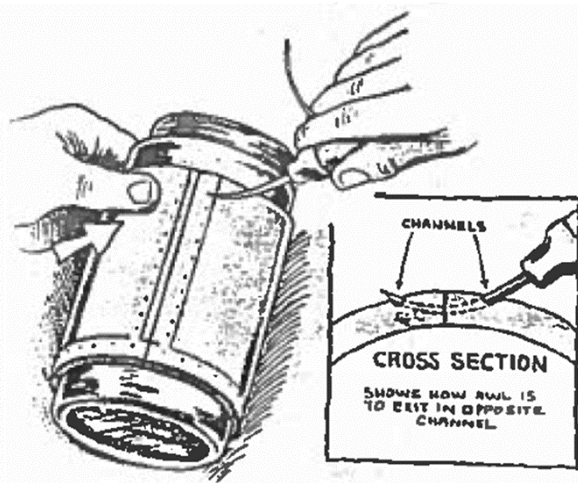
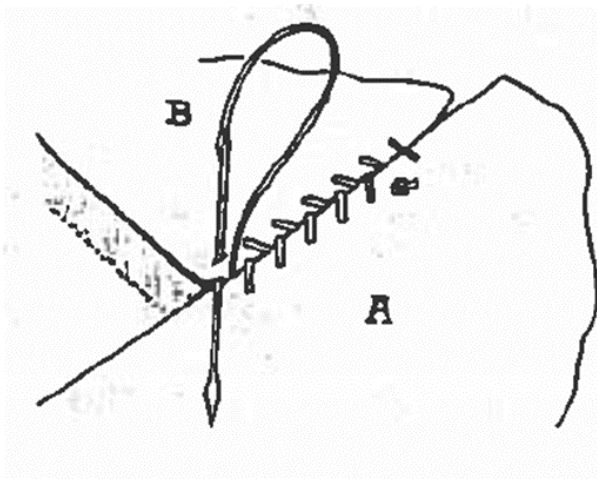

Look for different ideas for articles which can be made by sewing leather.

Hand Stitching Leather Techniques Video:

<https://www.youtube.com/watch?v=qj3BRWO7kuo&list=PL2v0zL3aZty-RPep7sBL6AB6gguOi3ZZ4&index=3>

Chapter 12—Constructing and Braiding Leather

In this chapter, you will learn to manipulate leather by lacing, braiding, expanding, sculpting or other techniques which include little or no decorative tooling and no sewing.

Expanded Leather

Expanding leather is the process of cutting flat pieces so they can be pulled out into unique shapes.

A circular shape is illustrated. This can be used as a candle holder, hanging planter, or to form the crown of a hat. You can probably think of many other uses.

Materials needed:

Heavy vegetable tanned leather

Sharp knife for cutting leather

Awl or similar pointed object

No. 1 and No. 3 round drive punches

Leather dyes and/or finishes of your choice

Board for protecting table surface while punching and cutting leather

Instructions

1. Make paper pattern or article.

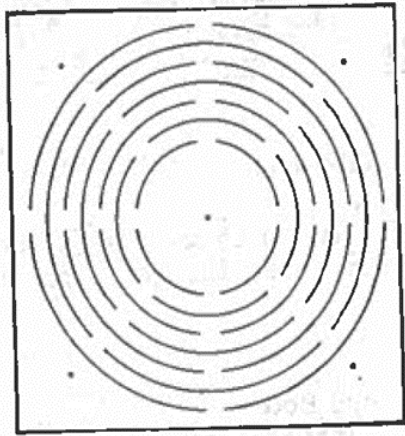

2. Transfer pattern to dampened leather with point of modeling tool, awl, or nail. Mark lines and locations of holes to be punched.
3. A saddler's compass or ruler may be used on leather to assure greater accuracy of parallel lines.

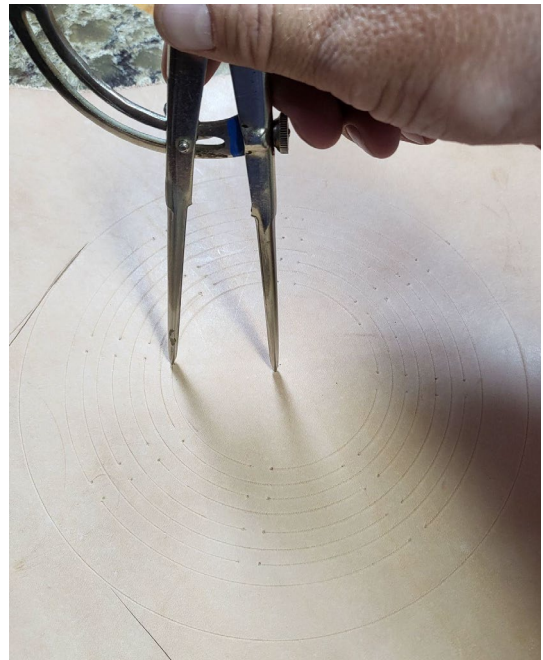

4. Punch holes at end of lines with No. 1 drive punch. This makes the leather less likely to tear at ends of cuts and also assures

smoother, more accurate ending of the cuts.
Makes holes for leather thongs with a No. 3
punch.

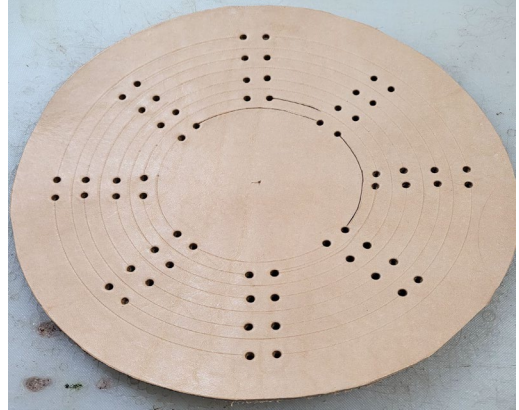

5. Carefully cut out the article with a sharp knife.

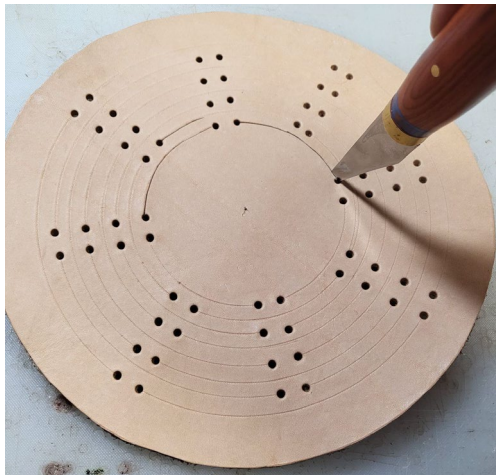

6. Cut the parallel lines. Be careful not to cut past the holes.

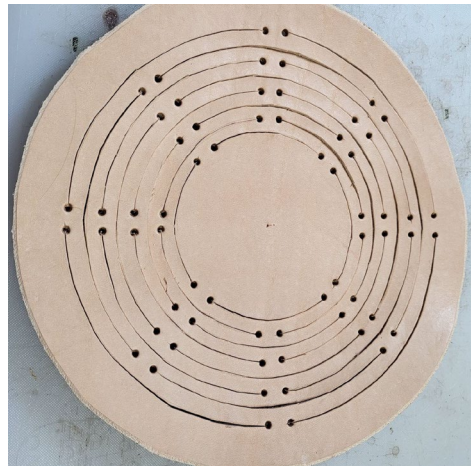

7. Apply dye or antique finish to flesh side, grain side and edges.

8. While the leather is still damp, shape the article over a can, bottle or other form and let dry.



Pool table pocket:



9. If hangers are required, tie leather thongs in holes punched in the outer ring. Insert ends of thongs through from flesh side to grain side then tie an overhand knot. The thongs may be tied together with an overhand knot.

Braiding

Braiding may be used on belts, bracelets, watch bands, earrings, bridles, reins, headstalls, riding crops, quirts, and bull whips.

Braiding may be flat, round, or square; used in knots, appliqué or edge lacings. It may be simple or complicated.

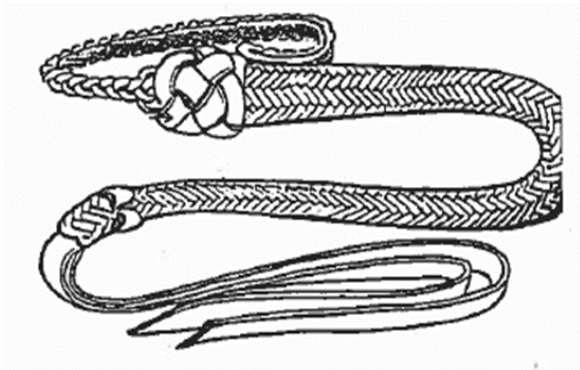

Select a pattern and follow the instructions carefully. Below are books you can use to learn more about braiding:

- Books by Bruce Grant on Leather Braiding:
http://www.goodreads.com/author/list/242582.Bruce_Grant
- Books by David W. Morgan on Leather Braiding:
https://www.davidmorgan.com/shop/product_info.php?products_id=78
- [Encyclopedia of Rawhide and Leather Braiding by Bruce Grant](#)

Mystery Belt

The Mystery Belt which is closed at both ends, yet braided in the middle might be interesting to make. Remember that braiding shortens a belt, so allow extra length.

Leather weight: 4/5 oz., heavier

Extra allowance per 12" braiding: 1 inch, 2 inches or more

Cut three equal dead-end slits in the center of the belt. Do not punch buckle tongue slots or holes until the belt is braided. The braiding punch will look better if edges of the strands are beveled.

1. Clamp the end of the belt to the bench.
2. Pass end through slit separating strands 2 and 3.
3. Pull all the way through with the end down.

4. Cross strand 1 over 2, 3 over 1, then 2 over 3. This forms braids A, B and C. Now pass end below point C between strands 2 and 3.
5. Pull all the way down. This eliminates all twists in the strands.
6. Continue braiding, forming D, E and F. This now completes the cycle. All strands are straight. Start the cycle over again with step 2. Pass the end between strands F and E. Pull down as in step 3.

7. Braid another A, B and C and pass end through as in step 4. Pull down as in step 5.
8. Braid another D, E and F. Continue the cycles until you have finished. Make slits longer, if necessary, to complete the cycle.
9. The last braids will not be as tight as the beginning. Clamp this end to the bench and begin tightening the last braids, gaining slack from the others.

Mystery Braid Leather Cuff Tutorial

<https://www.youtube.com/watch?v=41gFlbhYaM0>

Leather Mystery Braid Cuff - YouTube

<https://www.youtube.com/watch?v=bCEC4d-KaQU>

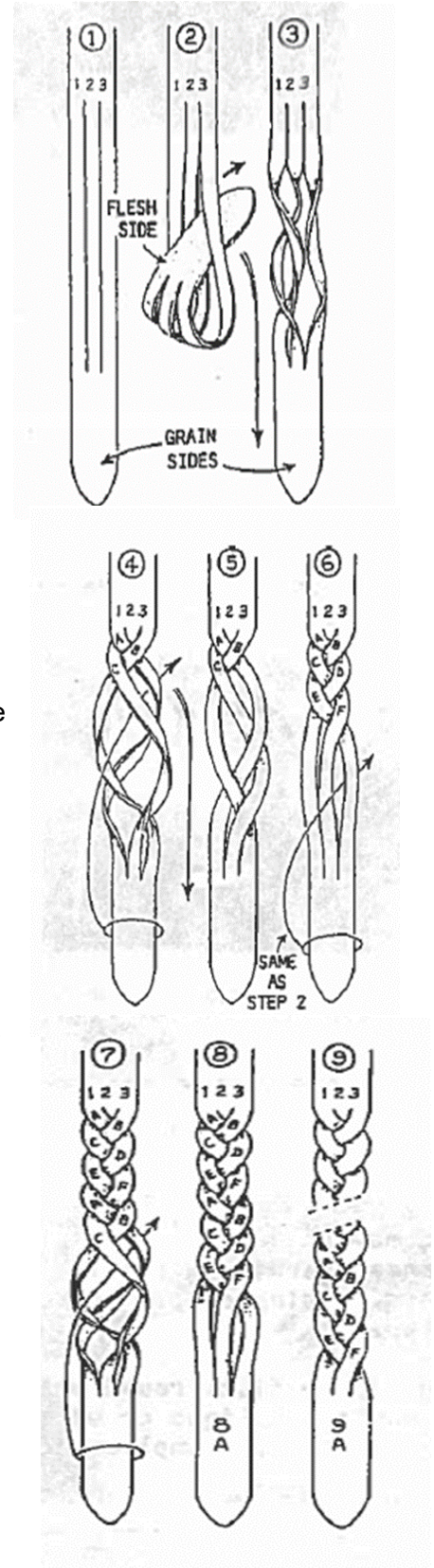

Collages and Other Art Forms

Collages can be made by gluing pieces of leather on a panel made of plywood, Masonite, or heavy cardboard. The background can be painted with acrylic paint, if desired, but be sure it is thoroughly dried before applying leather pieces.

Cut leather of desired shapes – geometric, abstract, flowers, fish, etc. Arrange the pieces on the background; then glue with transparent white resin glue. Apply glue to the flesh side of leather and press into place.



Chapter 13—Sewing Leather

Equipment and Supplies

A few special pieces of equipment are necessary for achieving professional looking leather articles constructed by sewing (hand or machine). Good instruction books on sewing leather should be consulted. Below are a few tips on how to use different tools for sewing leather.

- **Knife or razor blade:** A beveled skiving knife or single edged razor blade in a holder may be needed to skive seams for reduction of bulk or to obtain a consistent thickness where leather will overlap.
- **Mending tape:** Iron-on mending tape is helpful for reinforcing weak spots in the leather. This tape remains in place permanently.
- **Paper clips:** Paper clips may be used to baste seams. Push clip only part of the way over the seam allowance. The straight end of a clip is sharp and can mar the leather.
- **Rubber cement or leather cement:** These special cements are used to hold hems, facings, and seam allowances in place. They remain flexible and will not crack or become brittle. Cements can stain leather, especially suedes, so care is necessary during application. Test on a scrap first. Excess rubber cement can often be removed with a glue ball. To make a glue ball, allow some rubber cement to dry, roll into a ball and use it like an eraser.
- **Tape:** Tape is used to hold pattern pieces in place and for marking and basting. Try masking tape, transparent tape and hair setting tape to see which type works best. Tape can take the nap off suede or mar the surface of smooth leather. Always apply lightly and remove tape with care. Do not leave tape on leather any longer than absolutely necessary. Many leather suppliers have developed double sided tape for holding seams together when sewing.
- **Thimble:** Special thimbles with an attached gripper mechanism are available to aid in pushing and pulling a needle through double thicknesses of leather.
- **Triangular pointed sewing machine needle:** The triangular shaped point cuts cleanly for stitching without punching or tearing. Sheer suedes and soft leathers require a #11 needle; use #14 for medium weight suede and leather and #16 for heavy cowhide.
- **Twill tape or seam tape:** Woven tape is used to reinforce seams that receive great stress, to help keep the article or garment in shape.

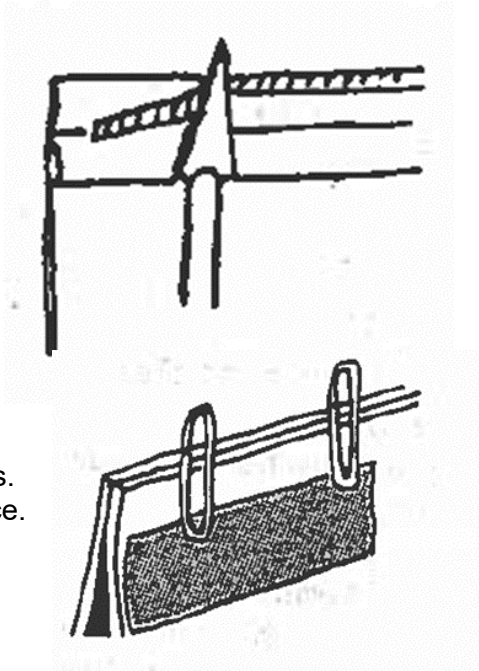

Selecting Patterns and Leather

Patterns

Study high quality leather furniture, ready-to-wear and other items for design and construction details before purchasing or designing a pattern. Almost any pattern that features simple, straight lines can be adapted for use with leather. Patterns designed especially for leather, simulated leather, and vinyl on the list of “suggested fabrics” are also available. These patterns have manageable ease and detailing suited to leather construction. Choose the pattern size you normally select when sewing woven fabrics.

Avoid patterns that feature eased seams, gathers, tucks, long points, or intricate styling. Patterns that have only a few large pieces do not lay out to good advantage, so piecing is often required. A pattern that features simple, straight lines may be divided into smaller sections for piecing without destroying the design. Trace the pattern onto brown paper and then divide into sections. Be sure to add seam allowances and fit the paper pattern on the person or item it is to cover.

Patterns designed for knits or very stretchable fabrics do not allow enough fitting ease to use with leather.

Leather Selection

Leather is sold by the square foot, skin or hide. This means you must convert yards into square feet or take the fitted pattern to the leather store and lay the pattern pieces on the available skins. Taking time to do an in-store layout will ensure purchase of the correct amount of leather. It also provides an opportunity to plan the layout to the best advantage so weak areas or holes in the leather can be avoided during the final layout.

Because leather is a natural product, it varies in weight, thickness, and quality. All skins that will be used for a garment, piece of furniture or other leather article should be purchased at the same time to ensure that color and thickness will be as uniform as possible. Make certain the leather selected is of an appropriate thickness for the pattern design.

Avoid skins that have large stiff areas. Purchase only leather that has been specially tanned for garment use or the purpose for which it will be used.

Cutting and Sewing

The “grain” in leather runs along the animal’s backbone. Cut all pieces the “long” way. An exception would be in small trim pieces which may be cut differently for contrast.

NOTE: Suede leathers have a “nap.” Lightly stroke each skin and match the nap so it runs the same direction on all pieces, or you will have different colors or shades on your finished article.

Place all pattern pieces on the leather before any cutting is done. This lets you rearrange the pieces and even redesign the pattern if there is not enough leather for a certain piece.

Cut only a single thickness of leather. Use sharp shears or a razor blade in the holder. If a knife or razor is used, a hardwood cutting board is needed. Cut with long, even strokes from the top

to the bottom of each piece. A rotary cutter can be used for long straight cuts (be careful to follow lines or use a guide such as a straight edge).

Put pattern markings on the back side of the leather with chalk, a marking pencil or fine ballpoint pen.

Needle holes made in leather are permanent. Use small pieces of tape or weights about every five or six inches to hold the pattern pieces to the leather.

Machine Stitching

Most sewing leather requires seven to 10 stitches per inch. The heavier the leather the longer the stitches must be. If stitches are too short, the leather will pucker, or the machine will skip stitches.

Generally, the pressure regulator must be set for less pressure because leather is thicker and spongier than most fabrics. Too much pressure will cause leather to mar during stitching.

Use a straight stitch throat plate (round hole) on machines that zigzag to prevent soft leather from catching in the needle hole.

Lightweight tissue paper placed between leather and the feed dogs of the machine helps keep the leather from bunching up and protects it from scuff marks.

Stitch from top to bottom of each piece and avoid stretching the leather as it passes through the machine.

When fabric and leather are seamed together, place fabric on top for best control.

Threads should be tied in a square knot to fasten stitches. Avoid backstitching as it tends to cut leather.

Stitch accurately the first time. Restitching cuts leather unless the stitches fall precisely in the original holes formed by the first stitching.

Seams

Leather stretches, so it is best to hold seams together with tape or paper clips. Do not sew over either tape or paper clips but remove them as you come to them. Cut a strip of pre-shrunk seam tape as long as the seam and sew it in with the seam. This will prevent stretching, especially at points of stress.

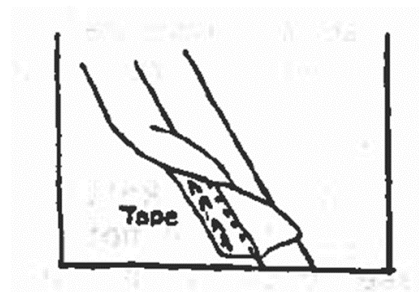

To flatten seams, press by pounding with a mallet.

Apply rubber cement to the tape and seam allowance of the leather. Some references suggest gluing only the part of the seam allowance which is close to the stitching and leaving the outside 1/8" unglued so ridges will not form on the right side of the garment.

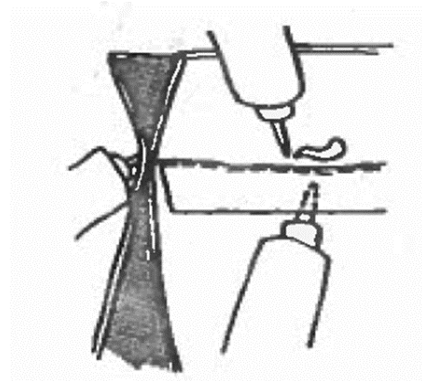
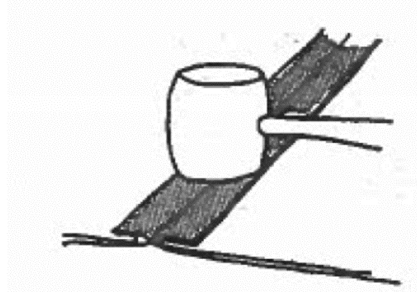

Press the seam down with your fingers and pound it with a mallet.

Allow the seam to dry, then lift the seam up lightly and press it back down to ease the tension and pull. Avoid using excess amounts of rubber cement. Do not cement any areas that will show on a finished suede garment because the cement will stain. Investigate seams other than the plain seam.

Darts

Crease darts along fold lines and pound to flatten the crease before stitching.

Stitch darts carefully from the wide part to the point.

Tie off threads to fasten. Trim the dart to within 3/8" of the stitching to reduce bulk. Very narrow darts are not opened but pressed toward the center.

Press or pound the dart open over a tailor's ham. Glue and fingerprints dart in place.

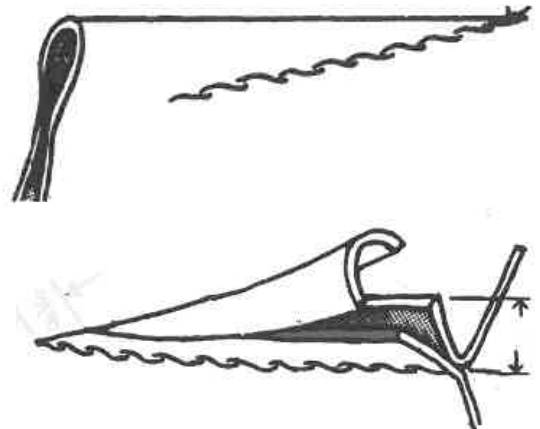

Hems

A hem should be marked on the fold line on the wrong side of the leather with a ballpoint pen. Brush rubber cement as far as the fold line. Now fold the hem up, pressing it with your fingers. Pound it gently with the mallet. The hem should be between 1" and 2" in width. If there is fullness in the hem so it will not lie flat, cut out small triangular pieces and ring the raw edges together.

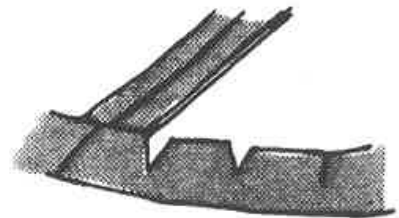

Linings

A leather garment should be lined to make it easy to slip on and off and to prevent the garment from stretching out of shape.

Chapter 14—Making and Rebuilding Saddles

The best way to learn to make or rebuild saddles is to find a saddle maker who is able to help teach you the process. Working with an experienced saddle maker will help you prepare for the project, work on the different parts, and then how to put it all together. **There are saddle making books that can give you good general information** as well. Using the references listed below may help you learn more about the world of saddle making!

As you research saddle making, here are three possible ways to go about making a saddle.

Make a saddle from a saddle pattern or kit. Purchase materials with everything needed to complete the saddle. Do all the tooling, assembly and finishing according to instructions provided.

Rebuild an old saddle. Secure an old saddle of the style you prefer. Study the saddle, and repair and/or replace those parts that need rebuilt. (More information below)

Custom build a saddle. The most difficult way to make a saddle is to buy a tree rawhide covered (or of your preference) of size and type to suit the rider and build the saddle from this point. This involves many hours of painstaking cutting and fitting of paper patterns to the tree to ensure a proper fit before any actual cutting of leather begins.

There are good books on saddle making available: See a resource list at the end of this book.

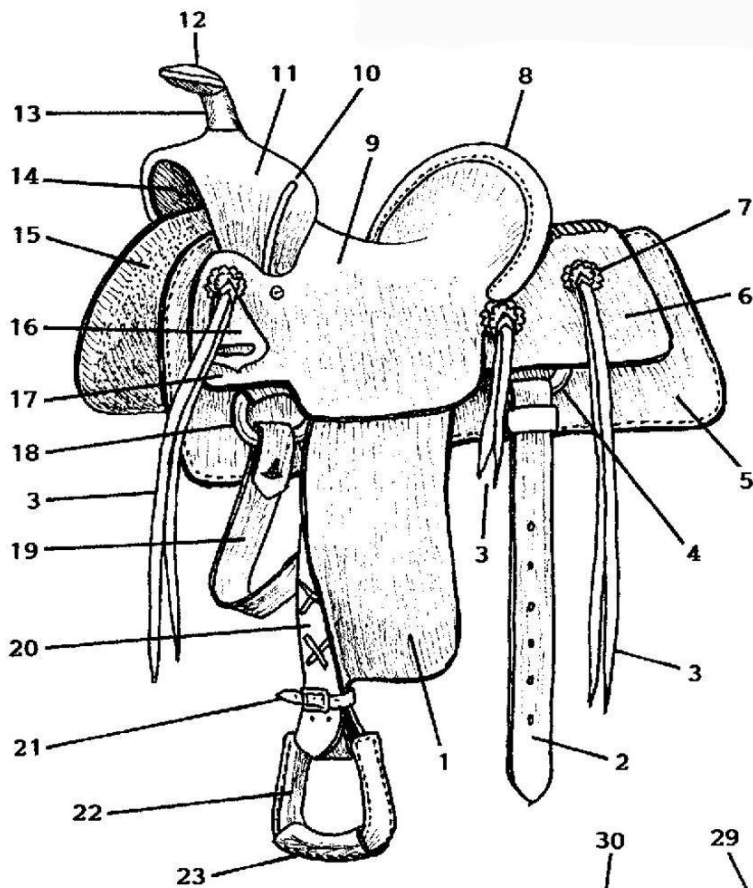

- 1 - Fender
- 2 - Flank Cinch Billet
- 3 - Saddle Strings
- 4 - Back Rigging Dee
- 5 - Skirt (square)
- 6 - Back Jockey (square)
- 7 - Rosettes (leather)
- 8 - Cantle
(regular binding)
- 9 - Seat
- 10 - Welt
- 11 - Swell Fork
- 12 - Horn Cap
- 13 - Horn Neck
- 14 - Gullet
- 15 - Shearling (lining)
- 16 - Latigo Holder
- 17 - Front Seat Jockey

- 18 - Front Rigging Ring
- 19 - Latigo (near side)
- 20 - Stirrup Leather
- 21 - Hobble Strap
- 22 - Stirrup
- 23 - Stirrup Tread
- 24 - Off-Side Latigo
(half-breed)
- 25 - Cinch Holder
- 26 - Rope Strap
- 27 - Slick Fork
- 28 - Hand Hole
- 29 - Padded Seat
- 30 - Cantle
(cheyenne Roll)
- 31 - Jockey Shield
- 32 - Back of Cantle
- 33 - Silver Concho
and Rosette
- 34 - Back Jockey (round)
- 35 - Skirt (round)
- 36 - Flank Cinch
- 37 - Connecting Strap
- 38 - Front Cinch (mohair)

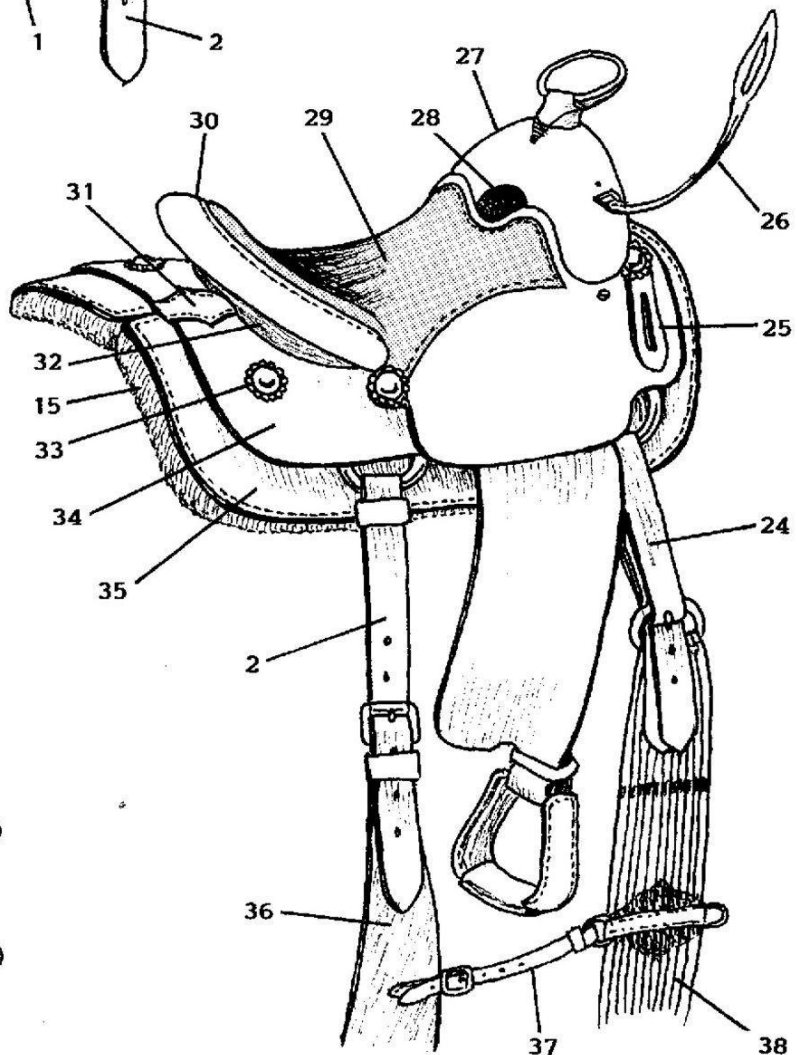

References and Resources

Art of Making Leather Cases Vol. 1, Al Stohlamn, 1979

Braiding Fine Leather, David Morgan, 1961

Coloring Leather, Al Stohlman, 1985

Encyclopedia of Rawhide and Leather Braiding, Bruce Grant, 2009

Good Reads, Bruce Grant Books, [Books by Bruce Grant \(Author of Leather Braiding\) \(goodreads.com\)](#)

How to Color Leather, Al Stohlman, 1954

Inverted Leather Carving, Al Stohlman, 1961

Leathercraft by Hand, Jan Faulkner, 1973

Projects & Design, Al Stohlman, 1972

Tandy Leather Library, <https://tandy-leather.com/blogs/leathercraft-library>

The Stohlman Encyclopedia of Saddle Making, Al and Ann Stohlman, 1993

Things to Make with Leather, Sunset Hobby & Craft Books, 1976

How to Carve Leather, Al Stohlman, 1952

Videos:

Leathercraft Basics, Elktracks Studio (free video):

<https://elktracksstudio.com/collections/videos/products/beginner-leatherworking>

Leather Lacing Techniques, Tandy Leather, 2011, [Leather Lacing Techniques - YouTube](#)

Hand Stitching Leather Techniques, Tandy Leather, 2011, [Hand Stitching Leather Techniques - YouTube](#)

How to Finish Exposed Edges On Leather, Tandy Leather, 2011, <https://www.youtube.com/watch?v=bTzT8PynuKk>

How to Set a Copper Rivet, Tandy Leather, 2011, <https://www.youtube.com/watch?v=p8Y1k5HKX0o&list=PL2v0zL3aZty8wJ7tcYTLLTrkFkEGXae0V&index=2>

How to Use a Safety Beveler on Leather, Tandy Leather, 2012, [How To Use A Safety Beveler On Leather - YouTube](#)

How to Use the Mini Punch Set on Leather, Tandy Leather, 2012, <https://www.youtube.com/watch?v=Ey29TOjmWqc&list=PL330E95D65DA4BA68&index=129>

Mystery Braid Leather Cuff Tutorial, Tandy Leather, 2011, [Mystery Braid Leather Cuff Tutorial - YouTube](#)

Setting Snap Fasteners On Leather, Tandy Leather, 2011, [Setting Snap Fasteners On Leather - YouTube](#)

Appendix

This appendix includes patterns from illustrations used in this manual and a few others that are helpful. You can use these patterns for practice or for your project!

Beginner Patterns

Coaster Pattern (3 ¼ inch)



Step 1: Trace



Step 2: Cut



Step 3: Camouflage

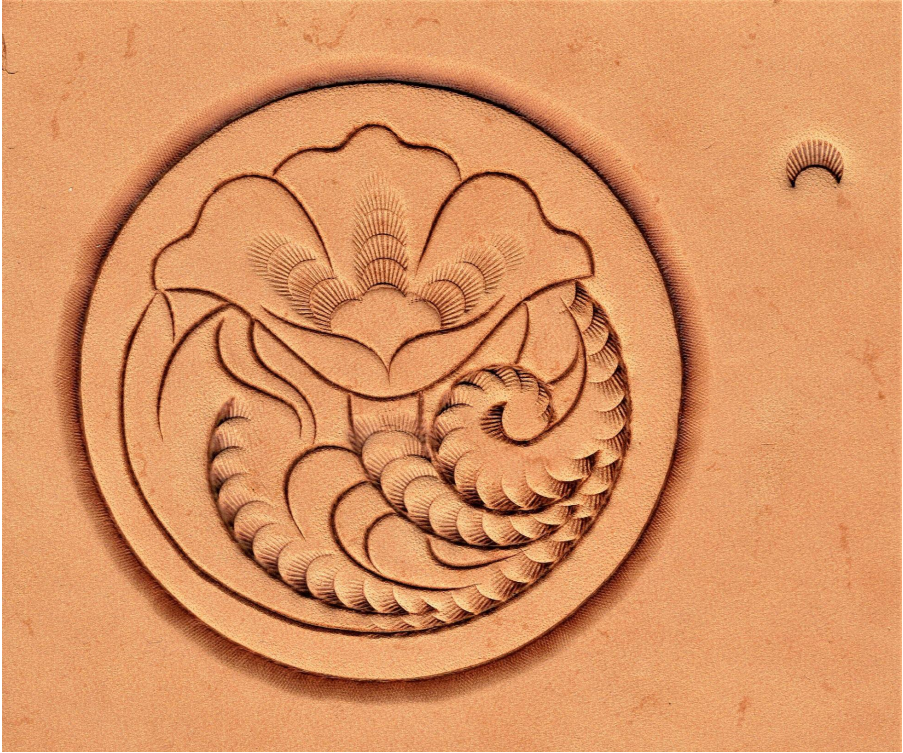

Step 4: Pear Shade

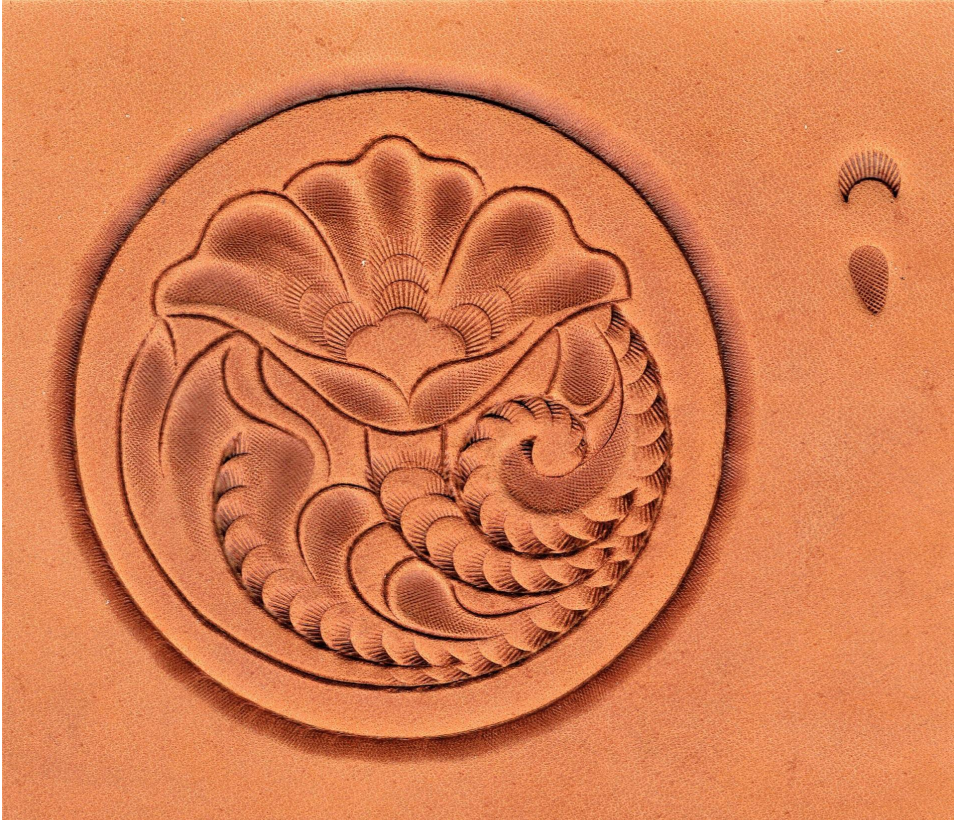

Step 5: Bevel



Step 6: Veiner

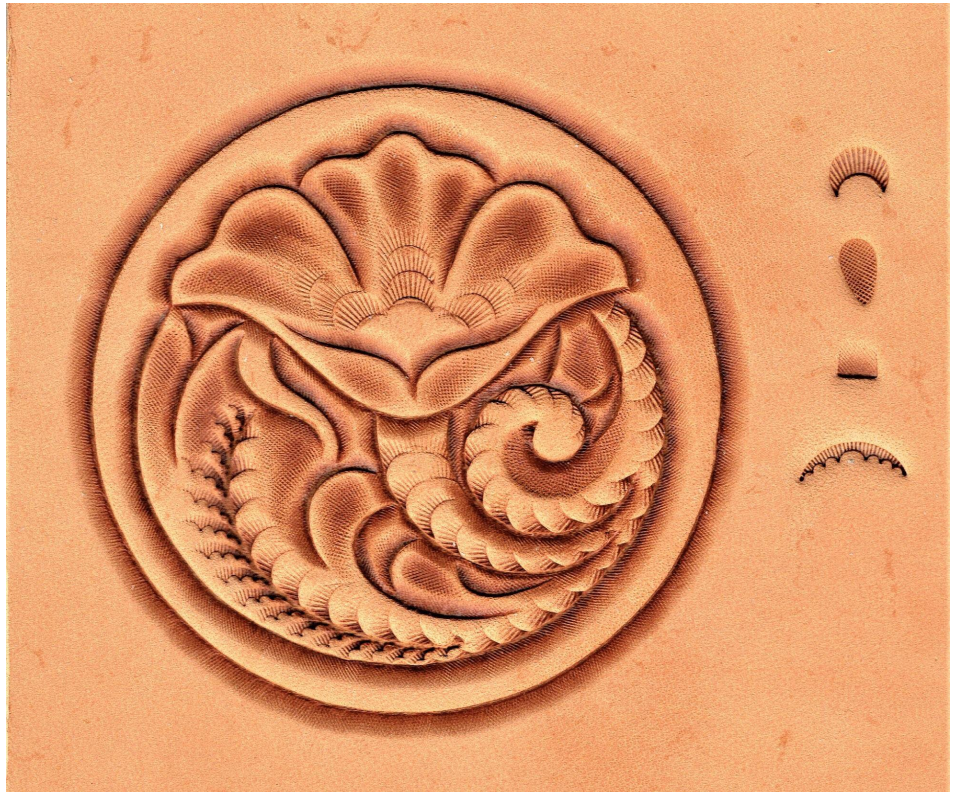

Step 7: Seeder



Step 8: Background



Step 9: Decorative Cuts



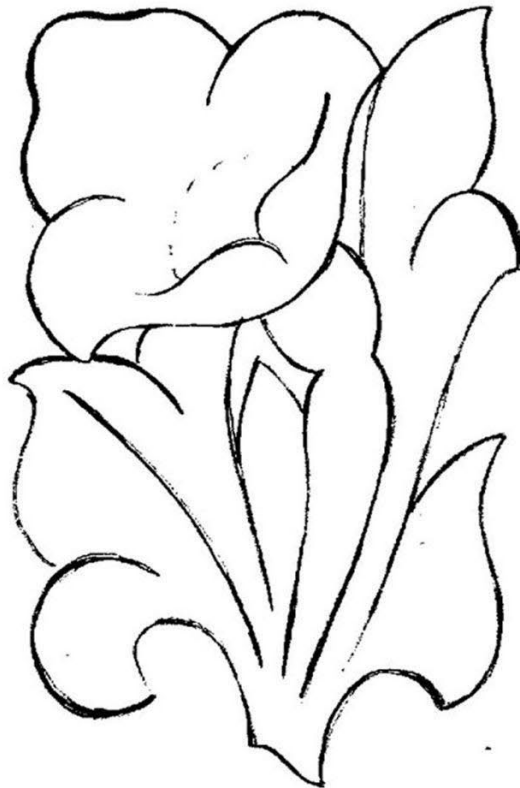

Beginner Pattern

This is flower
pattern to fit
on a 3 1/2
inch by 4 5/8
inch half back.

(1/2 of a
wallet size
piece of
leather is
called a
halfback.)



The six basic
tools, tracing
tool and
swivel knife
are used.

Trace,
swivel knife,
camouflage,
pear shade,
bevel, vein,
back ground,
and seed
tools are
used.

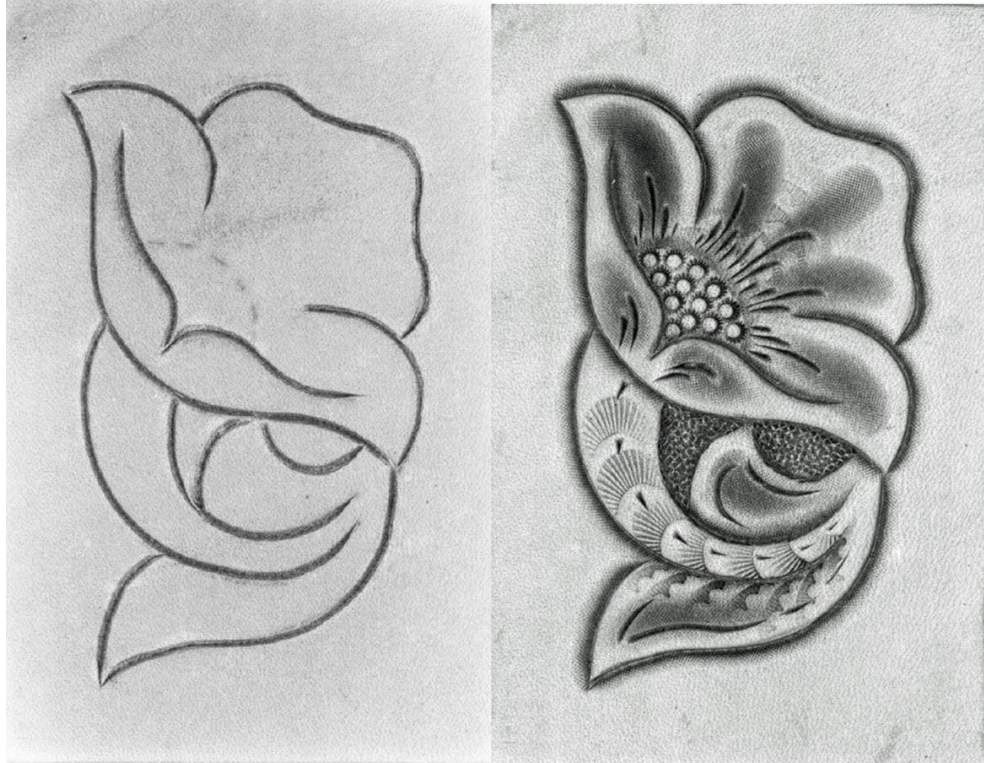

Beginner flowers

Tracing pattern and finished flowers.

Step by step instructions in Chapter 4, Traditional Carving

Basic tools used

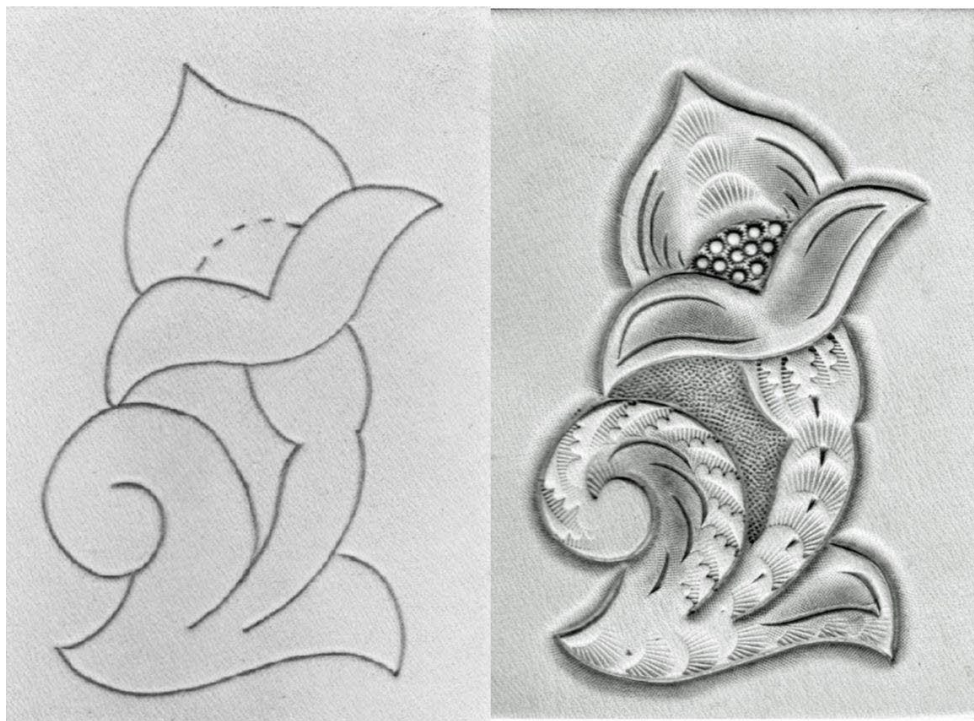

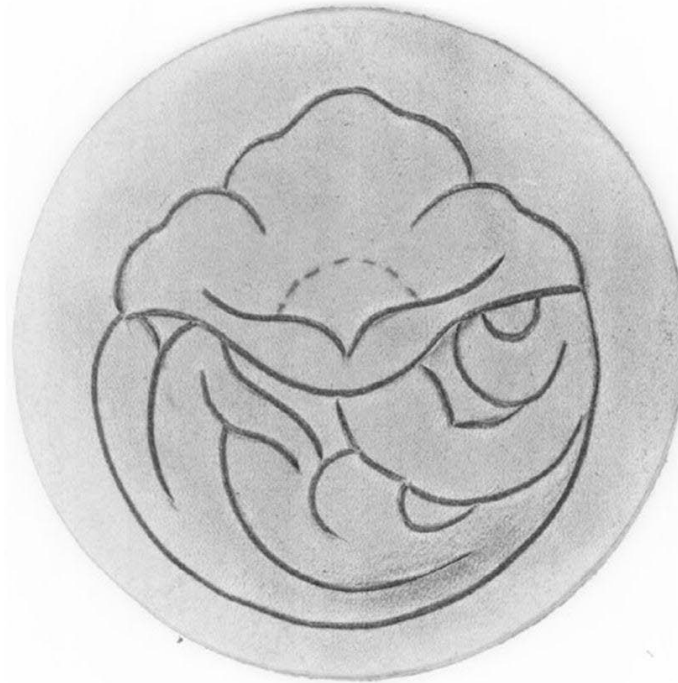

This is a beginning flower pattern to fit on a 3 1/2 inch rounder or coaster. It can be enlarged to fit a 4 inch rounder. The six basic tools, tracing tool and swivel knife are used. Trace, swivel knife, camouflage, pear shade, bevel, vein, back ground, and seed tools are used.



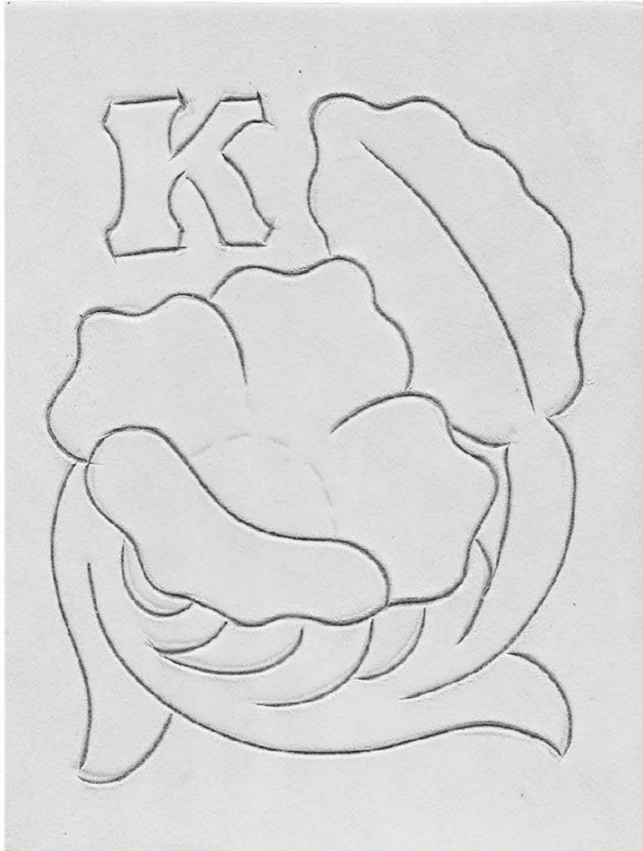

This is a beginning flower pattern to fit on a 3 1/2 inch by 4 5/8 inch half back.

(1/2 of a wallet size piece of leather is called a halfback.)

Any letter can be used or the space can be left blank.

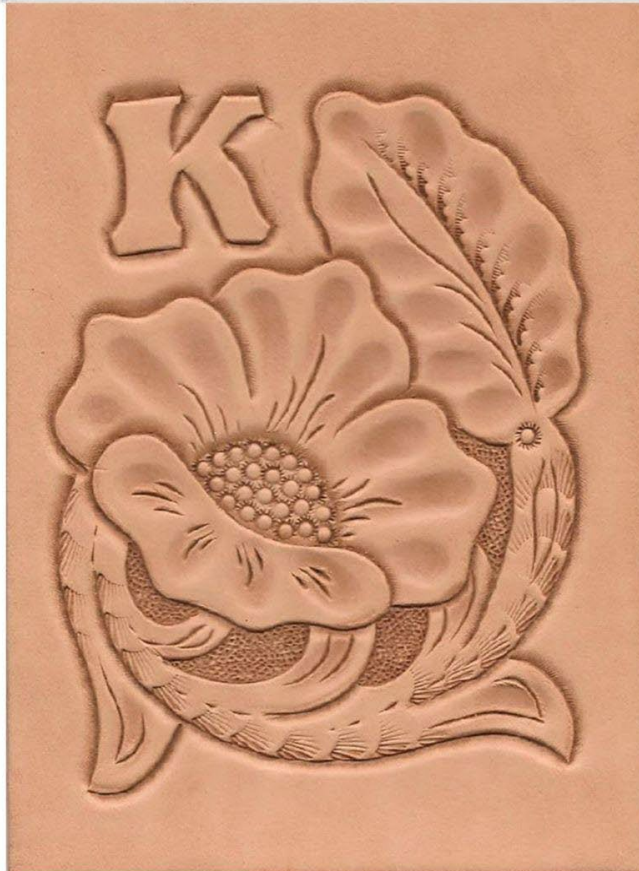

The six basic tools, tracing tool and swivel knife are used. Trace, swivel knife, camouflage, pear shade, bevel, vein, back ground, and seed tools are used.

Intermediate Patterns

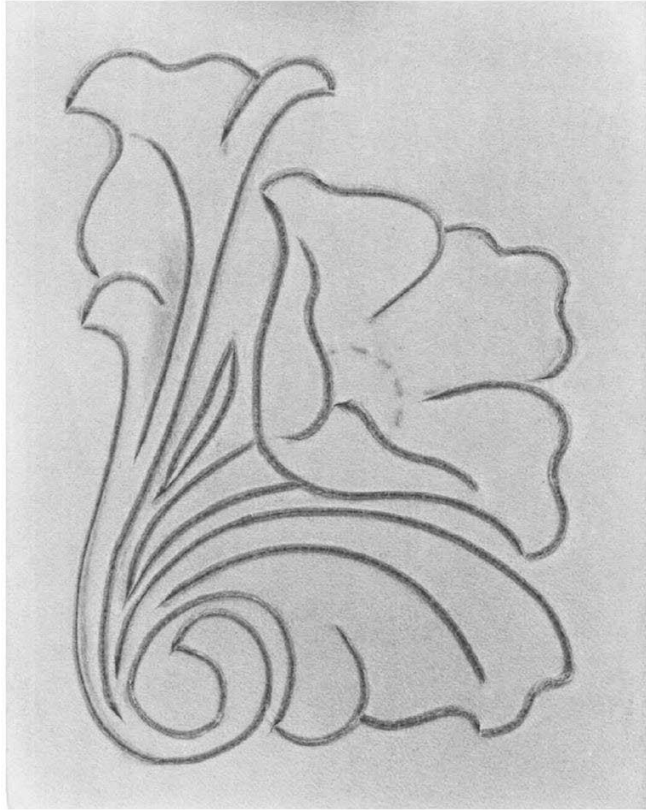

**Intermediate
Carving**

**Inverted
Carving**

Tracing pattern

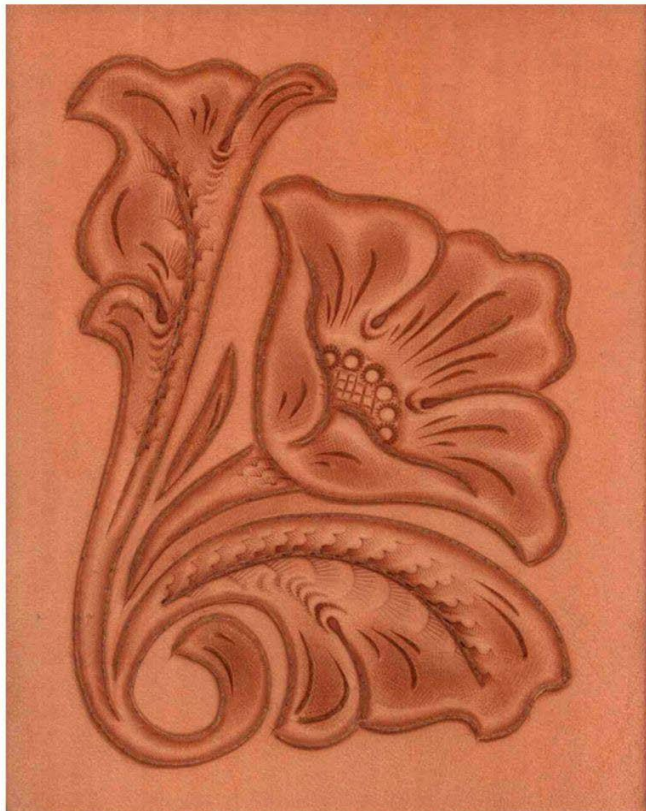

Tools used

Swivel Knife
Camouflage
Pear shader
Beveler
Veiner
Seeder
Stop
Mules foot



Tracing pattern (above)

This is an intermediate pattern to fit on a 3 1/2 inch rounder or coaster. It can be enlarged to fit a larger size. This pattern below is called rough out carving because it is tooled on the flesh side of tooling leather. The tracing tool, swivel knife, pear shader, beveler and backgrounder are used. This pattern can be done on the grain side of the leather also if desired.

Completed rough out tooling (below)



Advanced Patterns

Pictorial Carving

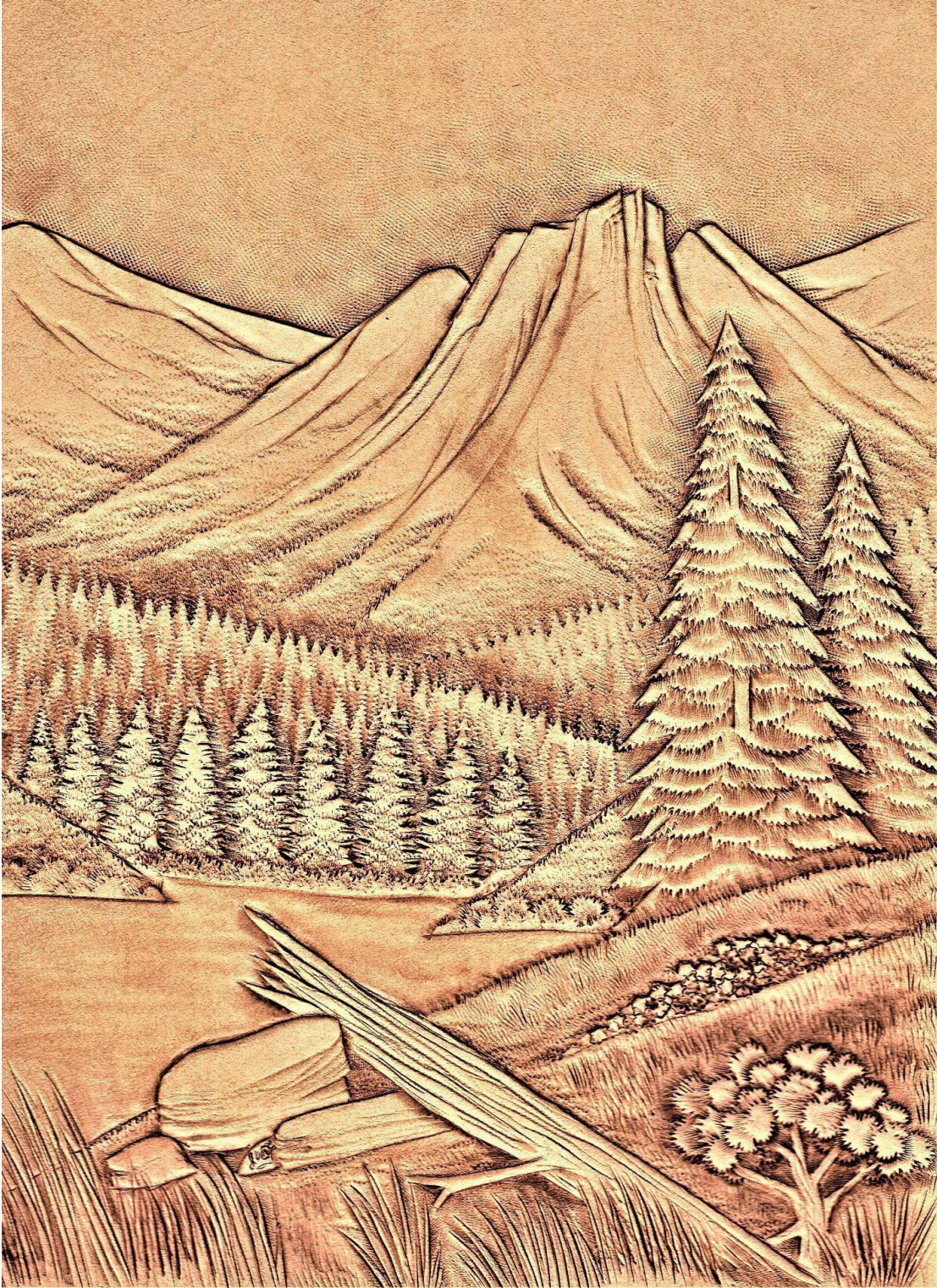

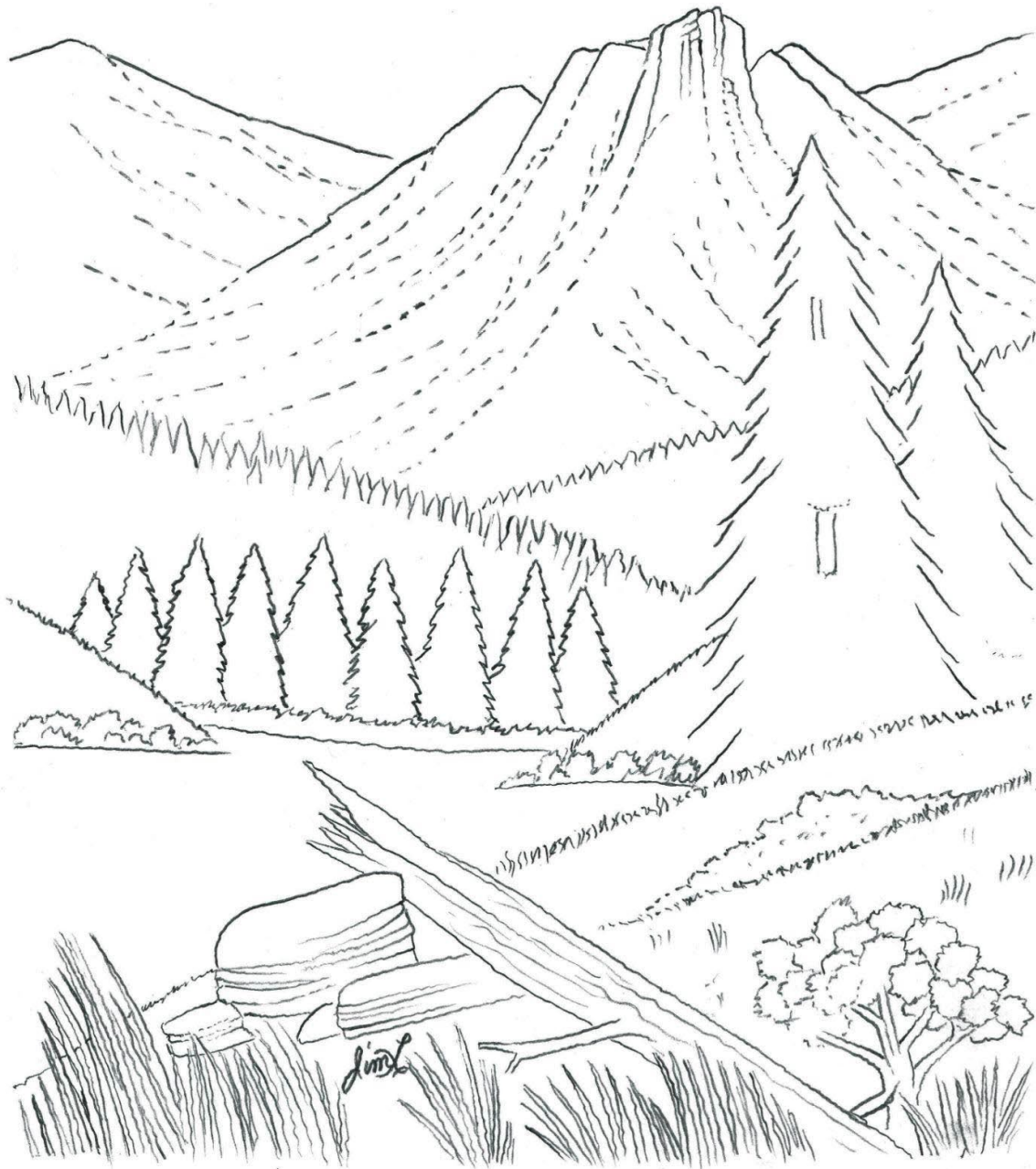

Horse Figure Carving





Colorado 4-H Mission

4-H empowers youth to reach their full potential by working and learning in partnership with caring adults.

Colorado 4-H Vision

A world in which youth and adults learn, grow and work together

4-H Pledge

I pledge...

My head to clearer thinking,
My heart to greater loyalty,
My hands to larger service,
My health to better living
for my club, my community,
my country and my world.

Promesa 4-H

Prometo usar mi mente para pensar con más claridad,
mi corazón para ser más leal,
mis manos para ser más servicial,
mi salud para cuidarme más,
por mi club, mi comunidad, mi país y mi mundo.

4-H Motto

“To Make the Best Better.”



COLORADO STATE UNIVERSITY
EXTENSION

Colorado4h.org