

TABLE OF CONTENTS

	PAGE
General Authority Statement.....	2
Supplemental Rules and Regulations.....	2
Scope and General Requirements.....	2
Permits	2
Certificate of Occupancy.....	3
Violations.....	4
Definitions.....	4
Open Burning, Recreational Fires, and Portable Outdoor Fireplaces.....	5
Fire Apparatus Access Roads.....	6
Aerial Apparatus Access Roads.....	7
Commercial and Industrial Developments.....	9
Fire Apparatus Access Road Gates.....	10
Premise Identification.....	10
Key Boxes.....	11
Fire Protection Water Supplies.....	11
Fire Hydrant Systems.....	13
Fire Hydrant Signs.....	14
Fire Protection Systems and Equipment.....	15
Portable Fire Extinguishers.....	18
Fire Alarm and Detection Systems.....	19
Emergency Egress Lighting.....	20
Fireworks.....	20

DELTA TOWNSHIP FIRE DEPARTMENT

General Authority Statement

INTERNATIONAL FIRE CODE 2015 EDITION-SECTION 104.1. The fire code official is hereby authorized to enforce the provisions of this code and shall have the authority to render interpretations of this code, and to adopt policies, procedures, rules and regulations in order to clarify the application of its provisions. Such interpretations, policies and procedures, **rules and regulations** shall be in compliance with the intent and purpose of this code and shall not have the effect of waiving requirements specifically provided for in this code.

Supplemental Rules and Regulations

Delta Township Code of Ordinances Sec. 16-49: The chief is authorized to render interpretations of this Code and to make and enforce rules and supplemental regulations in order to carry out the application and intent of its provisions. Such interpretations, rules and regulations shall be in conformance with the intent and purpose of this Code and shall be available to the public during normal business hours.

Scope and General Requirements

O101.1 **Title:** These regulations shall be known as the *Fire Code* of **Delta Charter Township**, hereinafter referred to as “this code.”

O101.3 **Intent:** State regulations prevail whenever state law or regulations provide a higher standard or requirement than is provided in the fire prevention code, the higher requirement or standard of this state law shall be followed in lieu of the requirement or standard of the fire prevention code. Said state standards or requirements shall be construed as part of this chapter as if fully set forth herein, and shall be enforceable as a part of this chapter.

Permits

S105.1.1 **Permits required** within Delta Township:

- 105.6.4 **Carnivals and fairs:** (see the International Fire Code)
- 105.6.14 **Explosives:** (see the International Fire Code)

- S105.6.30 **Open Burning:** An operational permit is required to conduct open burning on public or private property. (See Chapter 16 Article III of the Fire Prevention Code in the Charter Township of Delta Michigan Code of Ordinances.)
 - Open burning permits shall be issued primarily online via the Delta Township website. There is no fee for this permit. The following rules shall apply:
 - A wrong or fraudulent ID is subject to a misdemeanor per the International Fire Code.
 - The address on the ID must match the address location of the open burning.
 - Open burning may not be initiated until an official burn permit is received via email or in person (typically within 2 business days of the online application).
 - Burning permits requested in person after normal business hours shall only be for *Recreational burning*.
- 105.6.36 **Pyrotechnic special effects material** (see the International Fire Code):
- O105.6.43 **Temporary membrane structures, tents, and canopies:** An operational permit is required to erect or operate an air-supported temporary membrane structure or tent 200 square feet or larger, or a canopy 400 square feet or larger, except for structures used exclusively for camping. Tents shall not be erected for more than thirty (30) days in a single period or more than ninety (90) days in a calendar year.
- S105.2 **Application:** The Delta Township Board of Trustees has established a \$10.00 (ten dollar) fee for the following required permits: Explosives, Carnival and Fairs; Temporary Membrane Structures, Tents, and Canopies; and Pyrotechnic Special Effects Material. Fees shall be collected by a member of the Delta Township Fire Department prior to issuing any permit issued.

Certificate of Occupancy

S105.3.3 **Occupancy prohibited before approval:** A *Final* Certificate of Occupancy shall be issued by the authority having jurisdiction conditional upon the following:

- The completed project meets the conditions of the construction permit, the approved construction documents including all amendments, and all prior approvals.
- All required fees have been paid.

- All necessary inspections have been completed, and the completed project meets the requirements of the applicable *Codes* and the *Delta Township Supplemental Rules and Regulations*.
- All violations have been corrected, and any assessed penalties have been paid.
- All protective devices and equipment required to be installed by the applicable Codes and the Delta Township Supplemental Rules and Regulations will continue to be operational.

S105.3.4 **Conditional Permits:** A *Temporary* Certificate of Occupancy shall be permitted to be issued at the discretion of the fire code official for the use of parts or portions of a building prior to completion of the entire building.

Violations

O109.1 **Unlawful Acts:** It shall be unlawful to reset a fire alarm prior to the arrival of the fire department. Such acts shall be punishable up to a misdemeanor as required by the code.

O109.3.1 **Service:** It is acceptable for the notice to be sent electronically via email and shall serve as satisfying this section of the code.

O109.4 **Violation Penalties:** Persons who shall violate a provision of this code or shall fail to comply with any of the requirements thereof or who shall erect, install, alter, repair, or do work in violation of the *approved construction documents* or directive of the *fire code official*, or of a permit or certificate used under provisions of this code, shall be guilty of a **misdemeanor**, punishable by a fine of not more than **\$500.00** or by imprisonment not exceeding **93 days**, or both such a fine and imprisonment. Each day that a violation continues after due notice has been served shall be deemed a separate offense.

Definitions

O202 **Fireworks 1.4G:** Fireworks means that term as defined by the Michigan Fireworks Safety Act, Public Act 256 of 2011, and MCL 28.451 et seq.

O302.1 **Definitions:** New definitions added as follows:

- **Burning Barrel Fire:** Burning barrel fire means any fire in the vicinity of a residence within the curtilage of a dwelling; where the material to be burned has been placed in a

fireproof container constructed of metal or masonry, with an approved spark arrestor with openings not larger than ¾ of an inch.

- **Training Burn:** Training burn means any fire set by the fire chief or his designee for the purpose of training members of the fire department in the techniques of fire control, management or prevention.
- **Yard Waste:** Yard waste means lawn clippings, leaves, twigs and branches (excluding stumps) not more than three inches in diameter and not more than four feet in length; weeds, brush, shrub clippings and other plant matter which does not emit a foul or offensive odor when burned.

Open Burning, Recreational Fires, and Portable Outdoor Fireplaces

O307.2.1 **Authorization:** Where required by state or local law or regulations, open burning shall only be permitted with prior approval from the fire chief or his designee, provided that all conditions specified in the authorization are followed.

O307.4.1 **Bonfires and Recreational Fires:** A bonfire or recreational fire shall not be conducted within 25 feet of a structure or combustible materials. Conditions which could cause a fire to spread within 25 feet (7,620 mm) of a structure shall be eliminated prior to ignition. The size of the bonfire or recreational fire shall be limited to three feet by three feet by three feet.

O307.4.2 **Recreational Fires:** is hereby deleted.

O307.6 **Regulated Activities:** is a new section added as follows:

- O307.6 **Regulated Activities:** The fire chief is authorized to regulate all burning within the township.
- O307.6.1 **Open Burning of Yard Waste:** The burning of yard waste shall only be permitted in areas zoned A-1 or A-2 anytime during the calendar year with a permit.
- O307.6.2 **Bonfires and Recreational Fires:** Bonfires and Recreational fires may be permitted anytime during the calendar year with a permit.
- O307.6.3 **Training Burns:** Training burns may be permitted any time during the calendar year at the discretion of the fire chief or his designee.
- O307.6.4 **Burning Barrel Fires:** Burning barrel fires may only be permitted in areas zoned A-1 or A-2 any time during the calendar year and may only be used between sunrise and sunset.

- **O307.6.5 Open Burning for Development:** The fire chief or his designee may issue a permit for open burning on public or private property being cleared for the purpose of development or in cases deemed emergencies.

Fire Apparatus Access Roads

S503.1.1 Buildings and facilities: Approved fire apparatus access roads shall be provided for every facility, building or portion of a building hereafter constructed or moved into Delta Township. The fire apparatus access road shall extend to within 150 feet of all portions of the facility and all portions of the exterior walls of the first story of the building as measured by an approved route around the exterior of the building of facility (see **Figures 1 & 2**).

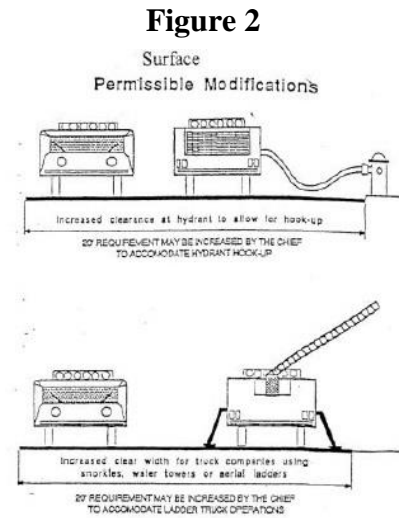
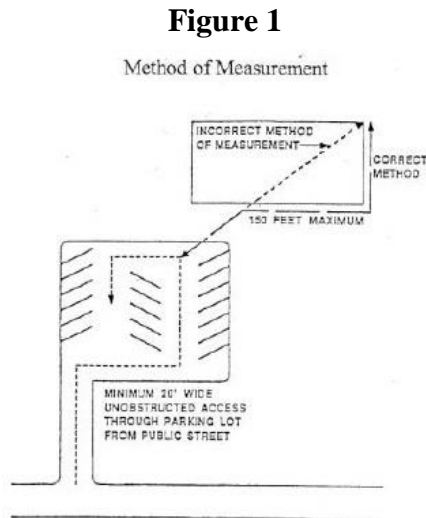

S503.2.1 Dimensions: Fire apparatus access roads shall have an unobstructed width of not less than 20 feet and an unobstructed vertical clearance of not less than 13 feet 6 inches.

S503.2.3 Surface: Facilities, buildings or portions of buildings shall be accessible to fire department apparatus by way of an approved fire apparatus access road with an asphalt, concrete or other approved driving surface capable of supporting the imposed load of fire apparatus weighing at least 75,000 lbs.

S503.3 Marking: Fire department access roads shall be marked with permanent NO PARKING—FIRE LANE signs complying with Figure 3 (see **Figure 3**). Signs shall have a minimum dimension of 12 inches wide by 18 inches high and have red letters on a white reflective background. Signs shall be posted on one or both sides of the fire apparatus road. Additional marking(s) shall be determined by the fire code official. All means by which fire

lanes are designated shall be maintained in a clean and legible condition at all times and replaced or repaired when necessary to provide adequate visibility.

Figure 3
No Parking Signs

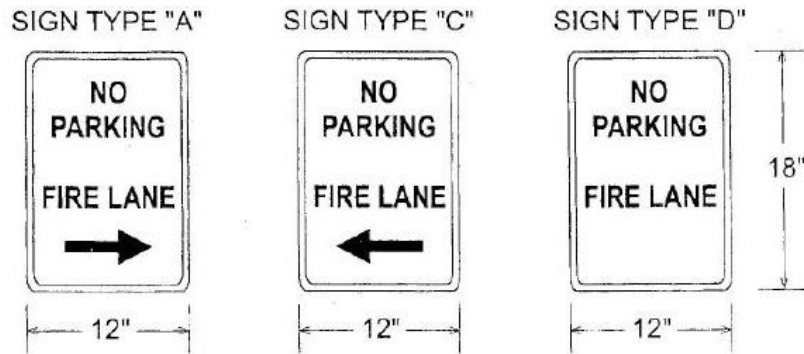

Aerial Apparatus Access Roads

S503.1 Where required: Buildings or portions of buildings or facilities with 3 or more stories or exceeding 30 feet in height above the lowest level of fire department vehicle access shall be provided with approved fire apparatus access roads capable of accommodating fire department aerial apparatus. Overhead utility and power lines shall not be located within the aerial fire apparatus access roadway.

S503.1.1 Buildings and facilities: At least one of the required access routes shall be located within a minimum of 15 feet and a maximum of 30 feet from the building, and shall be positioned parallel to one entire side of the building.

S503.2.1 Dimensions: Fire apparatus access roads shall have a minimum unobstructed width of 26 feet in the immediate vicinity of any building or portion of a building with 3 or more stories or more than 30 feet in height.

S503.2.4 Turning radius: The turning radius of a fire apparatus access road shall be constructed with a minimum turning radius of 36 feet at the inside curb line and a turning radius of 54 feet at the outside curb line (see **Figure 4**).

Figure 4

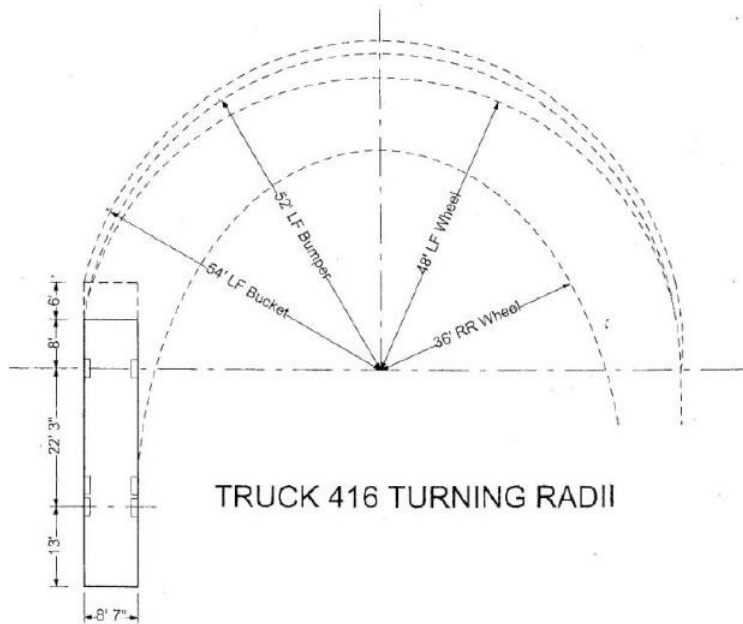

S503.2.5 DEAD-END TURNAROUND REQUIREMENTS: Dead-end fire apparatus access roads in excess of 150 feet in length shall be provided with width and turnaround provisions in accordance with Table D103.4 and Figure 5 and 6. (see **Table D103.4** , **Figure 5**, and **Figure 6**).

Table D-103.4

Requirements for Dead-End Fire Apparatus Access Roads

LENGTH (FEET)	WIDTH (FEET)	TURNAROUNDS REQUIRED
0-150	20	None Required
151-500	20	120-foot Hammerhead, 60-foot "Y" or 96-foot-diameter cul-de-sac in accordance with Figure 6.
501-750	26	120-foot Hammerhead, 60-foot "Y" or 96-foot-diameter cul-de-sac in accordance with Figure 6.
Over 750	Special approval required	

For SI: 1 foot = 304.8 mm.

Figure 5
Turnaround Required

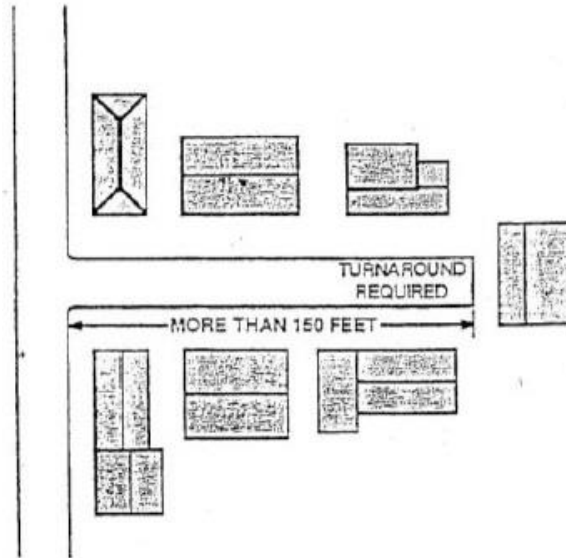
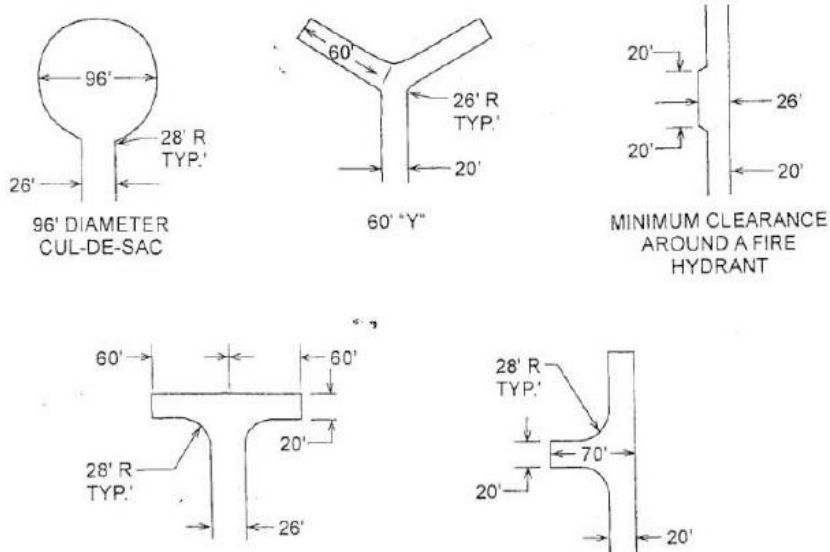

Figure 6
Examples of Dead-End Fire Apparatus Access Road Turnarounds



Commercial and Industrial Developments

S503.1.2 **Additional access:** Buildings or facilities exceeding 30 feet or 3 stories in height shall have at least three means of fire apparatus access to each structure. Buildings or facilities having a gross building area of more than 62,000 square feet shall be provided with two separate and approved fire apparatus access roads.

- *Exception:* Projects having a gross building area up to 124,000 square feet that have a single approved apparatus access road when automatic fire extinguishing system(s) are provided throughout and approved by the fire code official as an acceptable alternative.
- Where two access roads are required, they shall be placed a distance apart equal to not less than one half of the length of the maximum overall diagonal dimension of the property or area to be served, measured in a straight line between accesses.

Fire Apparatus Access Road Gates

S503.6 **Security Gates:** Gates securing the fire apparatus access roads shall comply with all of the following criteria:

- The minimum gate width shall be 20 feet with an unobstructed vertical clearance of 13 feet, 6 inches.
- Gates shall be of the swinging or sliding type.
- Construction of gates shall be of materials that allow manual operation by one person.
- Gate components shall be maintained in an operative condition at all times and replaced or repaired when defective.
- Electric gates shall be equipped with a means of opening the gate by the fire department personnel for emergency access. Emergency opening devices shall be approved by the fire code official.
- Manual operating gates shall not be locked with a padlock or chain and padlock unless they are capable of being opened by means of forcible entry tools or when a key box containing key(s) to the lock is installed at the gate location.
- Locking device specifications shall be submitted for approval by the fire code official.

Premise Identification

S505.1 **Address identification:** New and existing buildings shall have approved address numbers, building numbers or approved building identification placed in a position that is plainly legible and visible from the street or road fronting the property. Tenant spaces that are individually address shall display their address on the front of the building and the rear service door. All suites are required to display their suite number/letter on both the front and rear door.

These numbers shall contrast with their background. If on glass, they shall be white. Address numbers shall be Arabic numerals or alphabet letters. Numbers shall be a minimum of 4 inches high for residential dwellings and 6 inches high for commercial buildings.

S505.2 **Street or road signs:** All street or roads (public or private) shall be identified with approved signs per the Eaton County Address Ordinance as amended in 2007

Key Boxes

S506.1 **Where required:** A key box is required for every building hereafter constructed when said building has an automatic fire extinguishing system/fire alarm system or where immediate access is necessary for life-saving or firefighting purposes. Keys shall be provided by the owner, manager or occupant to the fire code official each time the lock(s) have been changed or rekeyed. The key to such lock shall be secured in the key box.

- **Location:** Key boxes shall be installed by the owner or his/her representative in an approved location. Key boxes shall be located at or near the entrances to structures or areas with gates. The key boxes shall be mounted no higher than 5 feet and no lower than 3 feet above finished grade.
- **Number:** Depending on the size and configuration of the structure, more than one key box may be required. Determination of the amount of key boxes shall be determined by the fire code official.
- **Order Form:** Appropriate order forms shall be issued by the Fire Prevention Bureau at the fire department administrative offices.

Fire Protection Water Supplies

S507.1: **Required water supply:** An approved required water supply capable of supplying the required fire flow or fire protection shall be provided to all premises upon which facilities, buildings, or portions of buildings are hereafter constructed or moved into Delta Township.

S507.3 **Fire Flow:**

One- and two-family dwellings: The minimum fire flow requirements for one- and two-family dwellings having a fire-flow calculation area which does not exceed 3,600 square feet shall be 1,000 gallons per minute. Fire-flow and flow duration for dwellings having a fire-flow

calculation area in excess of 3,600 square feet shall not be less than that specified in Table B105.1 (see **Table B105.1**).

- *Exception:* A reduction in required fire flow of 50%, if approved, is allowed when the building is provided with an approved automatic sprinkler system.

Buildings other than one- and two-family dwellings: The minimum fire-flow and flow duration for buildings other than one- and two-family dwellings shall be as specified in Table B105.1 (see **Table B105.1**).

- *Exception:* A reduction in required fire-flow of up to 75%, as approved, is allowed when the building is provided with an approved automatic sprinkler system. The resulting fire-flow shall not be less than 1,500 per minute for the prescribed duration as specified in Table B105.1.

Table B105.1

Minimum Required Fire Flow and Flow Duration for Buildings

FIRE AREA (square feet)					FIRE FLOW (gallons per minute) ² × 3.785 for L/min.	FLOW DURATION (hours)
× 0.0929 for m ²						
Type I-F.R. II-F.R. ¹	Type II One-HR. III One-HR. ¹	Type IV-R.T. V-One-HR. ¹	Type II-N III-N ¹	Type V-N ¹		
0-22,700	0-12,700	0-8,200	0-5,900	0-3,600	1,500	2
22,701-30,200	12,701-17,000	8,201-10,900	5,901-7,900	3,601-4,800	1,750	
30,201-38,700	17,001-21,800	10,901-12,900	7,901-9,800	4,801-6,200	2,000	
38,701-48,300	21,801-24,200	12,901-17,400	9,801-12,600	6,201-7,700	2,250	
48,301-59,000	24,201-33,200	17,401-21,300	12,601-15,400	7,701-9,400	2,500	
59,001-70,900	33,201-39,700	21,301-25,500	15,401-18,400	9,401-11,300	2,750	
70,901-83,700	39,701-47,100	25,501-30,100	18,401-21,800	11,301-13,400	3,000	3
83,701-97,700	47,101-54,900	30,101-35,200	21,801-25,900	13,401-15,600	3,250	
97,701-112,700	54,901-63,400	35,201-40,600	25,901-29,300	15,601-18,000	3,500	
112,701-128,700	63,401-72,400	40,601-46,400	29,301-33,500	18,001-20,600	3,750	
128,701-145,900	72,401-82,100	46,401-52,500	33,501-37,900	20,601-23,300	4,000	4
145,901-164,200	82,101-92,400	52,501-59,100	37,901-42,700	23,301-26,300	4,250	
164,201-183,400	92,401-103,100	59,101-66,000	42,701-47,700	26,301-29,300	4,500	
183,401-203,700	103,101-114,600	66,001-73,300	47,701-53,000	29,301-32,600	4,750	
203,701-225,200	114,601-126,700	73,301-81,100	53,001-58,600	32,601-36,000	5,000	
225,201-247,700	126,701-139,400	81,101-89,200	58,601-65,400	36,001-39,600	5,250	
247,701-271,200	139,401-152,600	89,201-97,700	65,401-70,600	39,601-43,400	5,500	
271,201-295,900	152,601-166,500	97,701-106,500	70,601-77,000	43,401-47,400	5,750	
295,901-Greater	166,501-Greater	106,501-115,800	77,001-83,700	47,401-51,500	6,000	
"	"	115,801-125,500	83,701-90,600	51,501-55,700	6,250	
"	"	125,501-135,500	90,601-97,900	55,701-60,200	6,500	
"	"	135,501-145,800	97,901-106,800	60,201-64,800	6,750	
"	"	145,801-156,700	106,801-113,200	64,801-69,600	7,000	
"	"	156,701-167,900	113,201-121,300	69,601-74,600	7,250	
"	"	167,901-179,400	121,301-129,600	74,601-79,800	7,500	
"	"	179,401-191,400	129,601-138,300	79,801-85,100	7,750	
"	"	191,401-Greater	128,301-Greater	85,101-Greater	8,000	

Fire Hydrant Systems

S507.5.1 Where required: Fire hydrants shall be provided along required fire apparatus access roads and adjacent public streets.

- The minimum number of fire hydrants available to a building shall not be less than that listed in Table C105.1. The number of fire hydrants available to a complex or subdivision shall not be less than that determined by spacing requirements listed in Table C105.1 when applied to fire apparatus access roads and perimeter public streets from which fire operations could be conducted (see **Table C105.1**).

Table C105.1

Fire Flow Requirement (gpm)	Minimum No. of Hydrants	Average Spacing Between Hydrants ^{1,2,3} (feet)	Maximum Distance From Any Point on Street or Road Frontage to a Hydrant
x 3.785 for L/min.		X 304.8 for mm	
1,750 or less	1	500	250
2,000-2,250	2	450	225
2,500	3	450	225
3,000	3	400	225
3,500-4,000	4	350	210
4,500-5,000	5	300	180
5,500	6	300	180
6,000	6	250	150
6,500-7,000	7	250	150
7,500 or More	8 or more ⁵	200	120

¹Reduce by 100 feet (30 480mm) for dead-end streets or roads.

²Where streets are provided with median dividers which can be crossed by firefighters pulling hose lines, or arterial streets are provided with four or more traffic lanes and have a traffic count of more than 30,000 vehicles per day, hydrant spacing shall average 500 feet (152.4 m) on each side of the street and be arranged on an alternating basis up to a fire-flow requirement of 7,000 gallons per minute (26 495 L/min.) and 400 feet (122 m) for higher fire-flow requirements.

³Where new water mains are extended along streets where hydrants are not needed for protection of structures or similar fire problems, fire hydrants shall be provided at spacing not to exceed 1,000 feet (305 m) to provide for transportation hazards.

⁴Reduce by 50 feet (15 250 mm) for dead-end streets or roads

⁵One hydrant for each 1,000 gallons pre minute (3785 L/min.) or fraction thereof.

Existing fire hydrants: Existing fire hydrants on public streets are allowed to be considered as available. Existing fire hydrants on adjacent properties shall not be considered available unless fire apparatus access roads extend between properties and easements are established to prevent obstruction of such roads.

Hydrant spacing: The average spacing between fire hydrants shall not exceed that listed in Table C105.1. Regardless of the average spacing, fire hydrants shall be located such that all points on streets and access roads adjacent to a building are within the distances listed in Table C105.1 (see **Table C105.1**).

- *Exception:* The fire chief is authorized to accept a deficiency of up to 10% where existing fire hydrants provide all or a portion of the required fire hydrant service.

Fire Hydrant Signs

S509.1 **Identification:** It shall be the responsibility of the property owner to provide and install approved hydrant signs in newly developed office, industrial, commercial and all other areas when required by the fire code official to indicate the location of all required on-site hydrants.

- Hydrant signs shall be of an approved type as adopted by the fire code official and shall be mounted on a minimum 9-foot green commercial sign post. The sign and post shall be located no closer than 3 feet to the rear of the hydrant. Signs on either side of the post maybe required to allow more visibility coming from any direction in parking lots, streets or private drives.
- The fire hydrant sign shall be 18 inches long and 8 inches wide. The sign shall be of a white fire hydrant with a white arrow pointing down on red background. The sign shall be installed so that it is 5 feet from finish grade to the bottom edge of the sign (see **Figure 7**).
- Coordinate with the Fire Code Official on the correct sign, post, location and direction prior to installation.

Figure 7

Fire Hydrant Signs

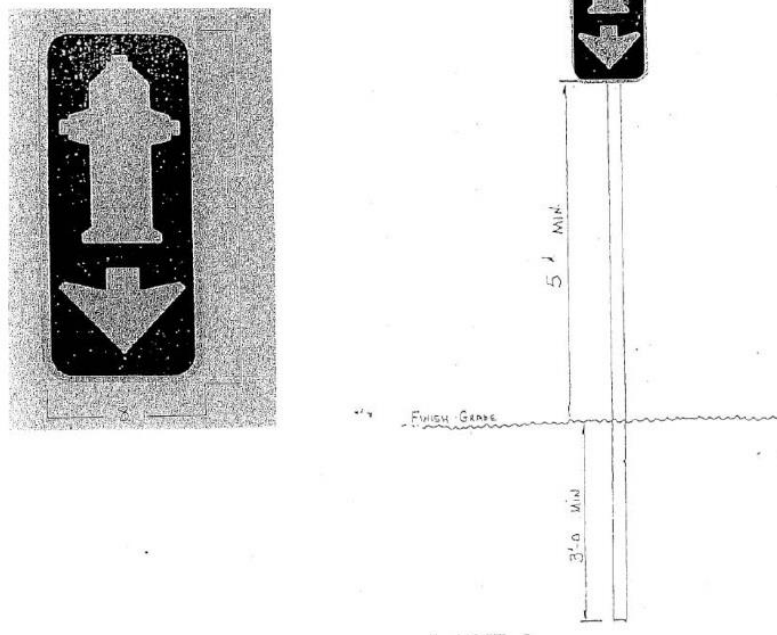

Fire Protection Systems and Equipment

S901.2 **Construction documents:** Sprinkler plans and water calculations shall be submitted electronically to the building and fire departments for review and approval prior to installation.

S901.4 **Installation:** All control, drain, test and alarm valves shall be provided with identification signs of standard design adopted by the automatic sprinkler industry. The test valve shall not be located more than 7 feet above the floor and readily accessible with discharge outlets.

- A name plate shall be installed on the riser giving information on calculations.
- The two-inch drain pipe shall drain to the outside at a point where it will cause no water damage. If difficult to comply, than the drain connections shall be sized to carry the water from open drains while discharging under normal water pressure.
- There shall be a pressure gauge located at each hose connection and at the top of all standpipe(s).
- There shall be a 2½ inch to 1½ inch reducer on all hose connections with NH threads for all standpipe(s).
- All new and existing fire protection systems shall have a placard located above the required fire department connection. The placard shall advise fire department personnel as to the level and location of the coverage of the fire department system within the building.
- Dry sprinklers shall be installed and connected to wet pipe sprinkler systems in areas subject to freezing temperatures. Sprinklers of sufficient length shall be used to avoid freezing of the water filled pipes and the clearance space around the sprinkler barrel shall be sealed.
- Fire protection equipment shall be identified in an approved manner. Rooms containing controls for air-conditioning systems, sprinkler risers and valves, or other fire detection, suppression or control elements shall be identified for the use of the fire department. The signs shall be permanently installed and readily visible.

S901.5 Installation acceptance testing: All tests to the system shall be witnessed by the fire code official and/or the mechanical/plumbing inspector.

- The fire sprinkler system is required to be tested at least annual by a fire sprinkler contractor. Owner is responsible to provide documentation of test to the Delta Township Fire Department Fire Prevention Bureau.

S903.3.7 Fire department connections: The sprinkler/standpipe fire department connection shall be located on the side of the building fronting the street or parking lot. A fire hydrant shall be located within 100 feet of the fire department connection. The distance must be a direct path for the apparatus.

- *Exception:* The fire department connection may be located on any side of the building that is provided with a fire lane and adequate water supply.
- The fire department connection shall not be installed less than 18 inches and nor more than 4 feet above the finished grade. Fire department sprinkler/standpipe connection(s) shall be placarded, i.e. sprinkler or standpipe connection (see **Figure 8**).
- The underground fire protection line into the building shall be equipped with a Yard Post Indicator Valve (YPIV) or Wall Post Indicator Valve (WPIV). The YPIV shall be located a minimum of 40 feet from the building (see Figure 8).
 - *Exception:* The YPIV may be closer, provided it is installed near the corner of the structure or otherwise protected from structural collapse.

Figure 8
Standpipe Systems

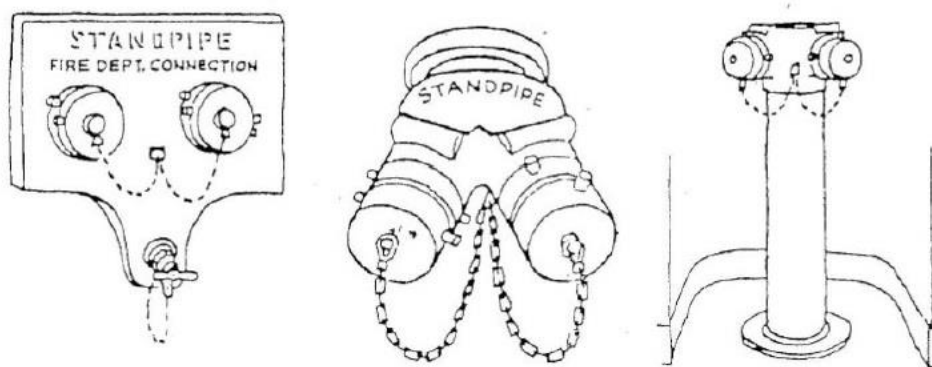
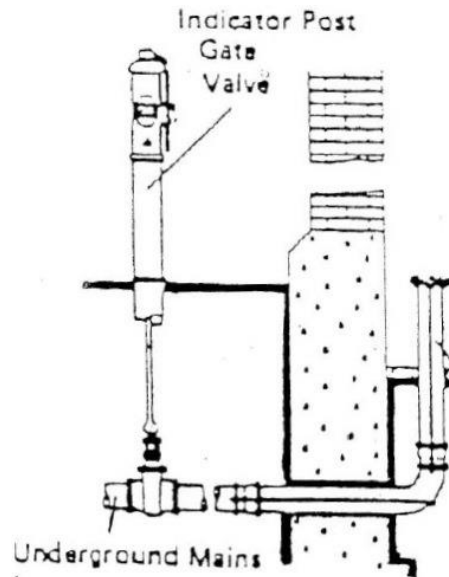

Figure 9

Indicator Post Gate Valve



S903.4 Sprinkler system supervision and alarms: In multi-tenant commercial buildings, water control valves shall be provided in each individual space. A flow switch shall be provided in each individual tenant space. Connected to the flow switch shall be a visible alarm device in an approved location on the front of the building for each and every tenant space.

- Yard or Post PIV's shall be electronically supervised and monitored by a fire alarm company.
- All interior and exterior valves controlling water supply for the automatic sprinkler system shall be electronically supervised, monitored, and chained and/or padlocked to prevent tampering as approved by the fire code official. A key shall be supplied to the fire department for the Knox box system.
- All water control valves shall transmit a supervisory signal when the valve is in any position other than OPEN.
- All flow and/or pressure switches shall be electronically supervised and monitored by a fire alarm company. Any movement of water in the system shall transmit an alarm signal.

S903.4.2 Alarms: There shall be approved visible and audible alarm(s) installed directly above the fire department sprinkler connection. The audible alarm shall be a 10-inch bell. The visual alarm shall be a flashing, rotating or oscillating red light (no strobes). The audible and visual

alarm shall both be installed a minimum of 12 feet high, or as approved by the fire code official. When the fire department sprinkler connection is not located on the side of the building fronting the street, there shall be a second red flashing, rotating or oscillating light installed on the front of the building.

- There shall be a separate red flashing, rotating, or oscillating light for each system or riser. Each light shall be numbered to correspond with the riser number.

Portable Fire Extinguishers

O906.2 **General Requirements:** Fire extinguishers shall be selected, installed and maintained in accordance with this section and NFPA 10, or as may be required by the fire code official.

O906.3 **Size and distribution:** Exceptions - Occupancy classifications Group A divisions 1-5; Group B; Group M and Group R divisions 1-4 shall be as follows:

- Portable fire extinguisher(s) in occupancies not equipped with automatic fire protection systems shall have a minimum rating of 4A-60BC (10 pound. multi-purpose) or equivalent with the maximum travel distance not to exceed 50 feet in any direction to an extinguisher.
- Portable fire extinguisher(s) in occupancies equipped with automatic fire protection systems shall have a minimum rating of 4A-60BC (10 pound. multi-purpose) with the maximum travel distance not to exceed 75 feet in any direction to an extinguisher.

O906.9. **Extinguisher installation:** Portable fire extinguishers having a gross weight not exceeding 40 pounds shall be installed so that its top is five feet above the floor. Hand-held portable fire extinguishers having a gross weight exceeding 40 pounds shall be installed so that its top is not more than 3½ feet above the floor. The clearance between the floor and the bottom of the installed hand-held extinguishers shall not be less than four inches.

Fire Alarm and Detection Systems

S907.2 **Where required-new buildings and structures:** A manual fire alarm box shall be installed within 5 feet of the main entrance for each space.

O907.3.1 **Duct smoke detectors:** Smoke detectors installed in ducts shall be listed for the air velocity, temperature, and humidity present in the duct. Duct smoke detectors shall be connected to the building's fire alarm control unit where a fire alarm is required by Section 907.2. Duct smoke detectors connected to the fire alarm control unit shall be a "smart" type detector capable of sending condition information and being reset from to fire alarm panel. Detectors shall, upon activation, perform the intended function and activate the alarm notification appliances or activate a visible and audible full alarm signal at a constantly attended location and shall perform the intended fire safety function in accordance with this code and the International Mechanical Code. Duct smoke detectors shall not be used as a substitute for required open area detection.

- Exceptions:

1. The supervisory signal at a constantly attended location is not required where duct smoke detectors activate the building's alarm notification appliances.
2. In occupancies not required to be equipped with a fire alarm system, actuation of a smoke detector shall activate a visible and an audible signal in an approved location. Smoke detector trouble conditions shall activate a visible or audible signal in an approved location and shall be identified as air duct detector trouble.

S907.4.2.5 **Protective covers:** Protective covers to prevent malicious false alarms are *required* for all new and remodel construction unless specifically authorized by the fire code official.

S907.6 **Installation:** The audience for the audible and visual alarm activation shall be all suites and/or tenants within the same fire rated wall as the initiated alarm, including but not limited to water flow, duct, and detectors per NFPA 72.

O907.6.5 **Monitoring:** An IP transmitter for fire alarm transmission is allowed but must be UL Standard listed. Any IP transmitters must have two modes of communication, one of which must be a POTS (Plain Old Telephone System) line.

Emergency Egress Lighting

O1006.3 **Illumination emergency power:** The emergency egress lighting shall be tested in dark conditions and witnessed by both the Delta Township Electrical Inspector and/or the Fire Code Official.

Explosives and Fireworks

5601.1 **Scope:** The sale, display, storage, transportation, or distribution of fireworks shall comply with the provisions of the Michigan Fireworks Safety Act, Public Act 256 of 2011, and MCL 28.451 et seq. Nothing in this section shall modify generally applicable township ordinances, including, without limitation, those regulating vendors, peddlers, transient merchants, solicitors, and hucksters.