

BOONVILLE BOARD OF WORKS
BOONVILLE CITY HALL
135 SOUTH SECOND STREETS
BOONVILLE, INDIANA
Wednesday June 13, 2018
4:00 pm

PRESENT: Mayor Charles Wyatt, Board members, Larry Lacer, Chuck Childress, Clerk Treasurer Tammy Boruff, and Attorney Brennan Phillips.

Absent: Attorney Mark Phillips

Mayor Wyatt called the meeting to order and asked all who wished to join in the Pledge to the Flag.

APPROVAL OF PREVIOUS MINUTES: Chuck Childress made a motion to approve the minutes of May 23, 2018. Larry Lacer second and the motion carried 3-0.

Citizen Comments:

Jerry L. Johnson Jr, from Johnson Construction, 1455 Homestead Dr., was present to ask permission to shut down a section of sidewalk and close off parking and the sidewalk along S. Second Street in front of the old gun shop. Shawn Wright of Veolia said the City needs to check on the location of down spout and location of water runoff.

Larry Lacer made motion to approve orange fencing blocking off the sidewalk for 1 week shutdown Chuck Childress seconded the motion carried 3 -0.

Angela Epley, 1093 Northwood Drive, was present to address the Board. She allowed someone to place a jumper on her water meter to fill up a pool with the intent to by-pass the water meter.

Mr. Phillips said that if Boonville City is going to pursue the theft charges with the Prosecutor then he advised Ms. Epley of her rights to remain silent because anything she says can be used against her; she said she understood. Larry Lacer asked if her intention was to steal water and she said yes.

Mayor Wyatt asked who put the jumper in and she said a guy overheard her at Wal-Mart talking to her husband about filling the pool. The man at Wal-Mart said if she paid him \$50.00 he would put in something to jump the meter and by pass her having to pay for the water. She did not know his name and she had deleted his number from her phone.

Shawn Wright, from Veolia said that the meter appeared damaged.

Brennan Phillips said if the City wants to pursue the theft issue the BOW can even after turning the Epley's water back on.

Larry Lacer made a motion to turn Ms. Epley's water back on but the City intends to pursue theft/vandalism charges regarding this case.

A letter from the Museum asking for the SW corner of the square could be used on 9-22-2018 for their sign. The Board asked Sara Hurt to let the Museum Board know that due to Construction we cannot approve the sign at this time.

Larry Lacer made a motion to deny the Museum Board this request Chuck Childress seconded and the motion to deny passed 3-0.

RECESS
RECONVENUE

Department Reports:

Police: Police Chief Daryl Saltzman submitted a Letter of Resignation effective July-8, 2018 from Caleb Wiseman.

Chief Saltzman said Paul Harper will be submitting his Letter of Resignation on July 9, 2018.

Applicants Zachary Virgin and Justice Goeken will be sworn in on July 9, 2018 at 3:00 p.m. They will start the Academy on July 12, 2018.

Purchase of new vehicles pricing:		
Chevy	\$34,471.50 x 2 = (trade in \$25,000.00)	\$ 43,943.00
Ford	\$31,430.36 x 2= (trade in \$21,500.00)	\$ 41,360.72
Dodge	\$29,240.00 x 2= (trade in \$21,500.00)	\$ 36,980.00

Fire Department:

Fire Chief Steven Byers gave the Building Addition time line from Midwestern

1. June 19 Advertise
2. June 27 Pre Bid
3. July 11 Open Bids
4. July 25 Issue Notice of Award

After participating in a CPR Instruction Class on 6-14-2018 through the American Heart Association the fire department will be a certified training center and have 5 CPR Instructors.

The Fire Department has been awarded a \$4,000.00 Grant to purchase ice rescue equipment.

Fire Chief Byers presented a Quote from Pro Air for Breathing Air Compressor & Cascade System for station and squad. They are a single source vendor and are used to fill SCBA and SCUBA cylinders with breathing air. The price is \$40,000 total. Larry Lacer made a motion to purchase the Breathing Air Compressor & Compressor & Cascade System from Pro Air who is a single source vendor in the amount of \$40,000; seconded by Chuck Childress and motion carried 3-0.

Fire Chief Byers presented a job description for a Safety Officer for the Fire Department would like to budget one man for this position in the future.

Veolia:

Shawn Wright stated at the last City Council meeting a request had been made by Councilman David Talley to put a guard rail system on Maple Grove Road. Shawn will investigate and get 3 quotes.

Shawn stated a Transfer switch at the sewage plant that switches the Power to generator power when we experience a power outage has caught fire during the last storm. He has filed a claim with our insurance company

When repairing a man hole at City Lake we found a unknown line at the base of City Lake which has created a hole.

Water Plant inspection with OUCC went well!!!!

AC at the Wastewater Plant's Main Lift station and blow building needs some upgrades. Shawn presented quotes for the Main Lift:

BNG	\$19,561.50
Hi Tech	No Response
Schindler Heating and Air	\$21,600.00

For Blower Building:

BNG	\$9,109.80
Hi-Tech Sheet metal, Inc.	No Response
Schindler Heating and Air	\$10,850.00

Chuck Childress made a motion to go with BNG for both the AC at Main Lift Station and Blower Building; Larry Lacer seconded motion carried 3-0

Shawn presented quotes to purchase new pumps and rail system at Aigner Lift Station because they have reached the end of their lives and the rail system in in dire need of replacement.

Straeffer Pump – 15 HP Meyers	\$11,092.00	Rails \$4,172.00 Total	\$15,264.00
KM Specialty Pumps – 15 HP Hydromatic	\$14,160.00	Rails \$4,636.00 Total	\$14,160.00
Xylem – Flytt 15 HP	\$13,509.70	Rails no quote	

Chuck Childress made a motion to purchase a new 15 HP Meyers Pump for \$11,092.00 along with the rail system at \$4,172.00 for a total price of \$15,264.00; Larry Lacer seconded the motion and motion carried 3-0.

NEW BUSINESS:

Mayor Wyatt presented Pay App #9 for Kieffer Brothers for \$139,109.38 for West Side Sewer Expansion. Chuck Childress made a motion to pay Kieffer Brothers for Pay App #9 in the amount of \$139,109.38; Larry Lacer seconded the motion and motion carried 3-0.

Mayor Wyatt presented Midwestern Invoice #14 for \$16,114.98 for inspection and engineering for West Side Sewer Expansion. Larry Lacer made a motion to approve for payment Midwestern Invoice #13 in the amount of \$19,238.46; seconded by Chuck Childress and the motion carried 3-0.

Mayor Wyatt presented Pay App #3 for Skill Electric for WWTP Solar Filed Equipment for \$9,645.00 for West Side Sewer Expansion. Chuck Childress made a motion to pay Skill Electric for Pay App #3 in the amount of \$9,645.00; Larry Lacer seconded the motion and motion carried 3-0.

Mayor Wyatt presented Pay App # 1 for Deig Brothers Lumber & Construction Co., for \$37,113.48 for commencement of construction up to 5/31/18 for 2018 Street Improvement Projects in regards to Community Crossing Grant. Larry Lacer made a motion to approve for payment to Dieg Brothers Pay App # 1 in the amount of \$37,113.48; seconded by Chuck Childress and the motion carried 3-0.

Mayor Wyatt presented a Fee schedule from VS Engineers in the amount of \$14,700.00 to provide lighting design and plan review for the downtown square project. Larry Lacer approved the fee schedule from VS Engineers in the amount of \$14,700.00; Chuck Childress seconded the motion and motion carried 3-0.

Mayor Wyatt asked the board to act on the program that was presented at the last BOW meeting from Reach Alert. Shawn presented a Reach Alert Flyer regarding a program which is a notification service which helps Administrators communicate timely information to everyone in your organization. The cost is \$3,000.00 a year. Chuck Childress made a motion to approve the Reach Alert Program; seconded by Larry Lacer and motion carried 3-0.

OLD BUSINESS: None

TAPS & ADJUSTMENTS: Larry Lacer made a motion to approve the water tap for Kerry App, 233 E. Gemlich Rd pending line cost from Shawn; Chuck Childress second and the motion carried 3-0.

Chuck Childress made a motion to approve a sewer adjustment for \$220.85 due to a hidden leak for Daniel Sams, 1227 Christopher Dr.; Larry Lacer seconded the motion and motion carried 3-0.

Chuck Childress made a motion to approve a sewer adjustment for \$5,744.38 due to a hidden leak for the Boonville City Spray Park, Mike Wilson director. Larry Lacer seconded the motion and motion carried 3-0.

Chuck Childress made a motion to table SassaFrassy's at 217 S. Third Street for a request for a credit of \$149.46 for more information. Larry Lacer seconded the motion and motion carried 3-0.

CLERICAL ADJUSTMENTS: Chuck Childress made a motion to approve all properly documented clerical adjustments. Larry Lacer second and the motion carried 3-0.

APPROVAL OF CLAIMS: Larry Lacer made the motion to approve all properly documented claims. Chuck Childress second and the motion carried 3-0.

ADJOURNMENT: Larry Lacer made the motion to adjourn. Chuck Childress second and the motion carried 3-0.

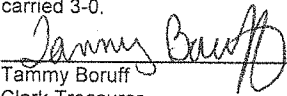

Tammy Boruff
Clerk Treasurer

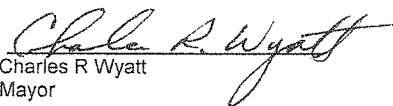

Charles R Wyatt
Mayor

**BOONVILLE BOARD OF WORKS
BOONVILLE CITY HALL
135 SOUTH SECOND STREETS
BOONVILLE, INDIANA**
Wednesday June 27, 2018
4:00 pm

PRESENT: Mayor Charles Wyatt, Board members, Larry Lacer, Chuck Childress, Clerk Treasurer Tammy Boruff, and Attorney Mark Phillips.

Absent: Attorney Brennan Phillips

Mayor Wyatt called the meeting to order and asked all who wished to join in the Pledge to the Flag.

APPROVAL OF PREVIOUS MINUTES: Chuck Childress made a motion to approve the minutes of June 13, 2018. Larry Lacer second and the motion carried 3-0.

Citizen Comments:

Tammy Recob, Pastor of Hemenway Church, was present to request Sycamore Street in Boonville be blocked off between Third St. and Fourth St. for a Family Fun Day on August 18, 2018 between the hours of 2:30 pm until 7:30 pm.

Chuck Childress made the motion to approve the request by Hemenway Church to block off Sycamore Street on Saturday August 18, 2018 from 2:30 pm until 7:30 pm; Larry Lacer seconded motion carried 3-0.

Richard Ellis, 8474 Melody Lane, Newburgh, was present on behalf of Wen Hai Li on 1133 N. Eskew Rd, Boonville. Mr. Li is in need of his lateral to be hooked up as soon as possible due to a failing septic system. Shawn from Veolia said we can approve a Tap for Wen Hai Li at 1133 N. Eskew Rd pending final completion approval from the contractor on Tuesday.

Larry Lacer made a motion to approve Sewer Taps from Wen Hai Li, 1133 N. Eskew Road and Dorothy Hadley 1233 N. Eskew Road pending substantial completion from Contractor on Tuesday; Chuck Childress seconded motion carried 3-0

New Business

Bid Openings: Attorney Mark Phillips opened bids for Demolition of two dilapidated buildings at Quail Crossing behind Red Barn are as follows:

Ray Stradtner, Certificate of Insurance included	\$7,850.00
Jerry Aigner, Certificate of Insurance included	\$8,200.00
Krantz Construction, Certificate of Insurance included	\$4,900.00

Larry Lacer made a motion to accept Krantz Construction to demo the two buildings at Quail Crossing behind Red Barn for \$4,900.00 Chuck Childress seconded motion carried 3-0.

Clerk Treasurer, Tammy Boruff, asked about setting up a Fund for Dog Park donations. Attorney Mark Phillips said the Park Board needs to do a Resolution creating a Dog Park in order to take donations.

**RECESS
RECONVENUE**

Department Reports: Police: Police Chief Daryl Saltzman said he had received a Resignation letter from Paul Harper his last day is July 9th.

Chief Saltzman said The Epley case has been sent to the Prosecutors office. Shawn Wright of Veolia stated the Tap was broke so the Epley's will be charged for this.

Fire Department:

Fire Chief Steven Byers stated there is a problem with phones at the Fire Department where the phones hook up in the closet. He received three quotes to replace phone, clean up wiring where phones hook up putting lock on telephone box and to change out equipment.

Business Communication Solutions	\$5,964.50
Midwest Telecom	\$6,964.00
AT &T	did not submit

Larry Lacer made a motion to go with BCS for \$5,964.50 Chuck Childress seconded motion carried 3-0.

Code Enforcement:

Jeff Floyd, Code Enforcement Officer got a call from Lowell Like asking him to check the Right of Way on 602 E, Division where it was determined that the dead tree is half on the City Right of Way and half on his property. Since half of the dead tree is on City Right of Way Mr. Like was asked to get three licensed quotes with Certificate of Insurance provided to remove the tree. Because it is half on the City Right of Way and a danger the City will pay half of the bill for taking the tree down.

Veolia:

Shawn Wright stated Tower Drive Lift Station metal is rusted inside and needs to be replaced will be submitting quotes soon.

OLD BUSINESS: None

TAPS & ADJUSTMENTS

Larry Lacer made a motion to table Sassa Frassy's at 217 S. Third Street. Chuck Childress seconded the motion to table and motion carried 3-0.

CLERICAL ADJUSTMENTS: Chuck Childress made a motion to approve all properly documented clerical adjustments. Larry Lacer second and the motion carried 3-0.

APPROVAL OF CLAIMS: Larry Lacer made the motion to approve all properly documented claims. Chuck Childress second and the motion carried 3-0.

ADJOURNMENT: Larry Lacer made the motion to adjourn. Chuck Childress second and the motion carried 3-0.

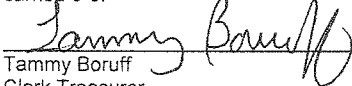

Tammy Boruff
Clerk Treasurer

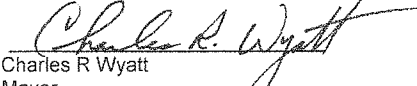

Charles R Wyatt
Mayor

**BOONVILLE BOARD OF WORKS
BOONVILLE CITY HALL
135 SOUTH SECOND STREETS
BOONVILLE, INDIANA
Wednesday July 11, 2018
4:00 pm**

PRESENT: Mayor Charles Wyatt, Board members, Larry Lacer, Chuck Childress, Clerk Treasurer Tammy Boruff, and Attorney Brennan Phillips.

Absent: Attorney Mark Phillips

Mayor Wyatt called the meeting to order and asked all who wished to join in the Pledge to the Flag.

APPROVAL OF PREVIOUS MINUTES: Chuck Childress made a motion to approve the minutes of June 27th, 2018. Larry Lacer second and the motion carried 3-0.

Citizen Comments: William Roberts, from FirstNet was present to do a presentation for FirstNet Mobile unlimited phone service with AT & T Wireless.

Department Reports: Code Enforcement Officer Jeff Floyd presented the following liens to be recorded:

Zahn, Jack & Patti Hicks & Catt Step Joan T Zahn	1221 Mayfair Dr.	\$350.00
Hayden, Robert	501 N. 9 th	\$350.00
Stinson, Beverly	712 N. 4 th	\$350.00
Birge, Mark S. & Ruth A	1108 Chariton	\$350.00
Mehling, Rebecca	332 Hudspeth Ave	\$350.00
Hines, Simuel	523 S. 7 th	\$350.00
Kiper, George A & Doris J	717 E. Oak Street	\$350.00
Miller, Audra J & Melissa Cameron	825 S. 3 rd Street	\$350.00
Broshears, John Sr. & Shannon J	Water Street	\$350.00
Zornes, Henry & Kathy	613 E. Division Street	\$350.00
Chase, Sharon	1003 Ann Street	\$350.00
Lucas, Klinton K & Kristan	302 N. 3 rd Street	\$350.00
Ness, Terri L	508 E. North Street	\$350.00

Larry Lacer made a motion to approve the above Sewer Liens to be recorded. Chuck Childress seconded the motion and motion carried 3-0.

Jeff presented quotes to have a dead tree removed on 602 E. Division Street after it was determined that the dead tree is located on half of the City's Right of Way.

J&J Tree Service	\$900.00	Certificate of Insurance included
American Eagle Tree Service	\$1275.00	No Certificate of Insurance included
S & S Tree Masters, Inc.	\$1000.00	Certificate of Insurance included

Larry Lacer made a motion to pay ½ of the \$900.00 quote from J & J Tree Service because the tree at 602 E. Division Street is located in half of the City's Right of Way. Chuck Childress seconded the motion and motion carried 3-0.

Chief Saltzman had a request from a school bus driver to check on a tree located at the corner of 3rd Street and Oak Street because of it being a safety hazard. Chief Saltzman and Code Enforcement Officer Jeff Floyd both feel this is a safety issue. Jeff Floyd sent the homeowner a certified letter advising her of the danger. The Board also asked him to measure the Right of Way on 3rd and Oak and see if the tree is in the City Right of Way.

Chief Daryl Saltzman informed the Board that National Night Out is August 7th from 5:00 - 7:00 pm at City Lake.

Chief Saltzman had previously submitted the quotes on 2 new police vehicles from:

Chevrolet Dealership	(2) \$34,471.50 each \$68,943.00 with a \$2500.00 trade-in = \$66,443.00
Ford Dealership	(2) \$31,430.36 each \$62,860.72 with a \$1,500.00 trade-in = \$61,360.72
Dodge Dealership	(2) \$29,240.00 each \$58,480.00 with a \$1,500.00 trade-in = \$56,980.00

After a lengthy discussion Chuck Childress made a motion to approve the proposal that Chief Saltzman presented for purchasing 2 new vehicles. Charles Wyatt seconded the motion and motion carried 2-1 with Larry Lacer voting no.

Shawn Wright of Veolia presented his report to the Board and updated on the following items:

Maple Grove Rail – Working on quotes
West Side Sewer – North Side – Substantial Completion signed
South Side – 50% Complete

Shawn Wright presented three quotes for CX55 B Excavator from:

Diamond Equipment - \$54,900

McKeel Equipment - \$63,990

Vandco - \$62,698.00

Chuck Childress made a motion to purchase the CX55 B Excavator from Diamond. Larry Lacer seconded the motion and motion carried 3-0.

Shawn Wright explained the pump from Wasson Drive Lift Station had a seal failure from debris getting wrapped around the impeller. The pump needs repair to make the station fully operational again. The pump is from a single source vendor and will cost \$2,363.97 to repair the pump. Chuck Childress made a motion to use Straeffler Pump & Supply who is a single source vendor to repair the Wasson Drive Lift Station pump in the amount of \$2,363.97. Larry Lacer seconded the motion and motion carried 3-0.

Shawn Wright presented the City of Boonville Utilities Standard Drawing for sewer service lateral specifications. Larry Lacer made a motion to accept the City of Boonville Utilities Standard Drawing for sewer service lateral specifications and to attach to all sewer inspection tags and permits. Chuck Childress seconded the motion and motion carried 3-0. (see Attachment A)

Chuck Childress made a motion that any repair work that requires a new sewer line to existing service must meet the new City of Boonville Utilities Standard drawing for sewer service lateral specifications. Larry Lacer seconded the motion and motion carried 3-0.

Shawn Wright presented Utility Right of Way Easements for approval. Larry Lacer made a motion to approve Utility Right of Way Easements Parcel 2 Permanent and 2 A Temporary in exchange for a sewer tap and \$500 for Parcel 3 Permanent Easement and 3A Temporary Easement for Dennis & Cathleen Mullen who has 4 parcels and because we had to cross the other 3 lots. Chuck Childress seconded the motion and motion carried 3-0.

Larry Lacer made a motion to approve permanent Utility Right of Way Easement Parcel 4 in exchange for a Sewer Tap and a temporary Utility Right of Way Easement Parcel 4A for John & Ellee Mullins. Chuck Childress seconded the motion and motion carried 3-0.

Larry Lacer made a motion to approve permanent Utility Right of Way Easement in exchange for a Sewer Tap and a temporary Utility Right of Way Easement for Greg & Maria Stanten and Tony & Linda Sandage. Chuck Childress seconded the motion and motion carried 3-0.

Shawn Wright explained that due to the extra cost of pipe in the Westside Water Project the amount previously approved on January 24, 2018 has increased by \$4938.51 making the total amount for the project \$77,083.96. Chuck Childress made the amendment of the previous approved price of \$72,145.45 to \$77,083.96 for the Westside Water Project. Seconded by Larry Lacer and motion approved 3-0.

Recess Reconvene

Attorney Brennan Phillips said it was brought to his attention during the recess that it was a possible conflict for Chuck Childress to vote on police cars because he works part time for the Police Department. Chuck Childress rescinded his motion and vote.

Larry Lacer then made a motion to trade in the 2005 Chevy Impala that the Water Department was currently using toward the 2 new Chevy Silverado Trucks and then the Water Department will pay General \$3500.00 for the 2009 Chevy Impala. The 2013 Chevy Silverado Truck will then be transferred to the Parks Department and \$11,000 out of the General Obligation Bond will be paid toward the purchase of the police vehicles. Charles Wyatt seconded the motion and motion carried 2-0 with Chuck Childress abstaining.

Charles Wyatt made a motion to purchase 2 new Silverado's trucks from Law Chevrolet in the amount of \$68,943.00 less \$2500.00 trade in making them \$66,443.00 because they were the most responsive police package. Larry Lacer seconded the motion and motion carried 2-0 with Chuck Childress abstaining.

Chief Daryl Saltzman requested Officer Matthew Brown and Trevor Winters be removed from probation status to First Class Patrolman.

Larry Lacer made a motion to removed Trevor Winter from probation status retroactive as of 5-14-18 and Matthew Brown on 7-2-18. Chuck Childress seconded the motion and motion carried 3-0.

Fire Chief Steven Byers presented 2 separate incident reports involving Assistant Fire Chief John Dohrn which happened June 19th and June 20th to each of the Board members during recess and was instructed by Attorney Brennan Phillips to read the reports but no discussion would be held. If the Board feels the need to discuss the issue then an Executive Session would need to be called in 48 hours to discuss. Fire Chief Byers recommended a written reprimand for the incident on July 19th, 2018 and a 3 day Suspension on July 12, 13 & 16th for incident on June 20th, 2018 without pay and on July 17th, 2018 at 7:00 AM John Dohrn will be removed as Assistant Fire Chief and back to 1st Class Fireman.

Chuck Childress made a motion to approve the recommendations from Fire Chief Steven Byers for a written reprimand for the incident on July 19th, 2018 and a 3 day Suspension on July 12, 13 & 16th for incident on June 20th, 2018 without pay and on July 17th, 2018 at 7:00 AM John Dohrn will be removed as Assistant Fire Chief and back to 1st Class Fireman. Larry Lacer seconded the motion and motion carried 3-0.

Fire Chief Steven Byers recommended Brandon Cason is moved into the Assistant Fire Chief position as of July 23rd, 2018. Larry Lacer made the motion to approve Brandon Cason is moved into the Assistant Fire Chief position as of July 23rd, 2018. Chuck Childress seconded the motion and motion carried 3-0.

NEW BUSINESS: None

OLD BUSINESS: None

TAPS & ADJUSTMENTS:

Chuck Childress made a motion to approve the adjustment for Daniel Sams of 1227 Christopher Dr., in the amount of \$153.77 for a hidden leak. Larry Lacer second and the motion carried 3-0.

Chuck Childress made a motion to approve the adjustment for Nicholas Beckort of 297 Persimmon Circle in the amount of \$160.62 for a hidden leak. Larry Lacer second and the motion carried 3-0.

Chuck Childress made a motion to approve the adjustment for Michael Forston of 202 W. Locust Street in the amount of \$746.39 for a hidden leak. Larry Lacer second and the motion carried 3-0.

Chuck Childress made a motion to approve the adjustment for Chris Williams of 716 Kiper in the amount of \$408.62 for a hidden leak. Larry Lacer second and the motion carried 3-0.

Chuck Childress made a motion to approve the following Swimming Pool – Fill Affidavits:

Alice Christian	418 North 3 rd Street	\$30.71
Teresa Keiffer	420 West Locust Street	\$47.24
John Dorsey	313 E. Elm Street	\$17.71
Tom Dorsey	311 E. Elm Street	\$70.86
Sara Numm	1224 N. Rockport Rd	\$62.59
Misty Hay	1266 Stonehaven Circle	\$180.69

Chuck Childress made a motion to deny Tractor's Supply to waive a late fee of \$32.59. Larry Lacer seconded the motion and motion carried 3-0.

Larry Lacer made a motion to approve a 6 month contract for Mary Biddle to pay her bill of \$678.02 for 322 N. 4th Street. Chuck Childress seconded the motion and motion carried 3-0.

CLERICAL ADJUSTMENTS: Chuck Childress made a motion to approve all properly documented clerical adjustments. Larry Lacer second and the motion carried 3-0.

APPROVAL OF CLAIMS: Larry Lacer made the motion to approve all properly documented claims. Chuck Childress second and the motion carried 3-0.

ADJOURNMENT: Larry Lacer made the motion to adjourn. Chuck Childress second and the motion carried 3-0.

Tammy Boruff
Clerk Treasurer

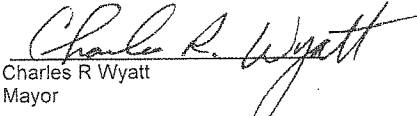
Charles R Wyatt
Mayor

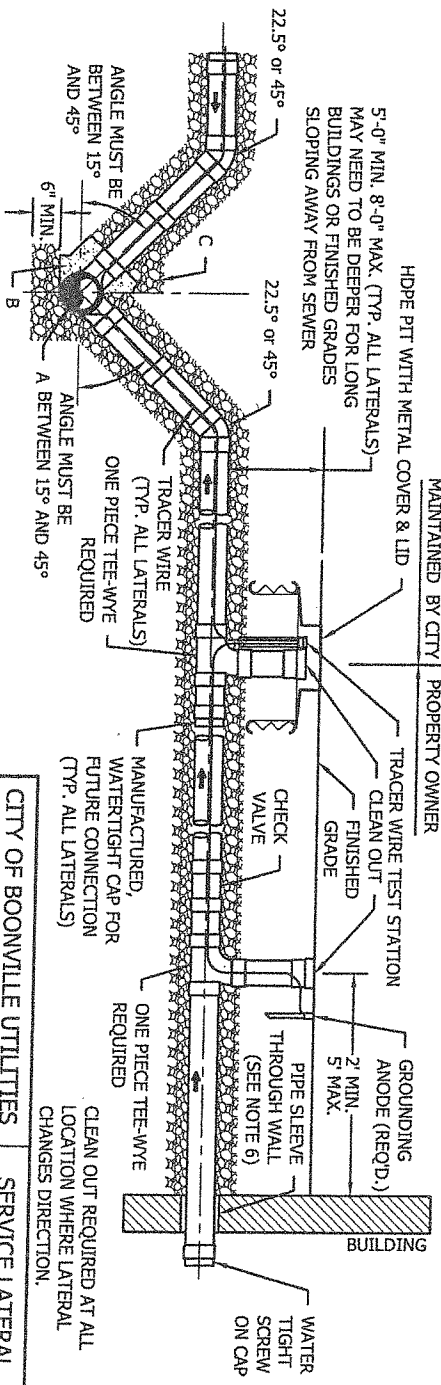
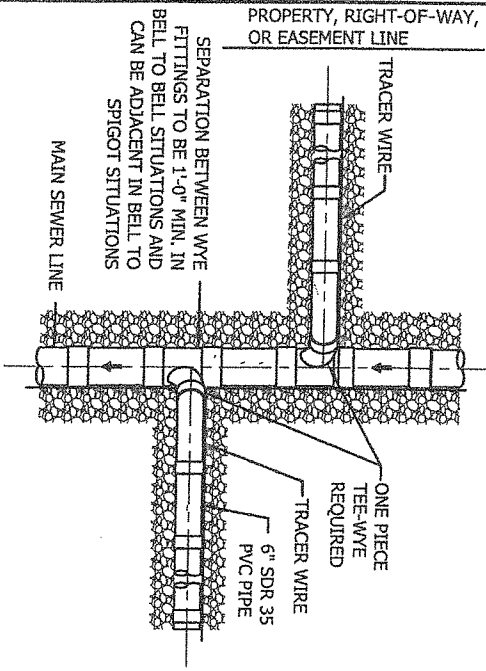

- NOTES:
1. ALL FITTINGS SHALL BE SDR 26.
 2. DEPTH OF SERVICE LATERAL SHALL BE MEASURED FROM FINISHED GRADE TO THE TOP OF MAIN SEWER LINE.
 3. ALL LATERAL BEDDING SHALL BE AGAINST UNDISTURBED TRENCH.
 4. MINIMUM FALL IS 2% PER FOOT, TYPICAL OF ALL LATERALS.
 5. PIPE REQUIREMENTS PER DEPTH ARE AS FOLLOWS:
 3'-12" SDR-35
 12'-25" SDR-26
 OVER 25' SDR-23.5
 6. THE PIPE PENETRATION THROUGH A BUILDING WALL SHALL BE PROTECTED FROM BREAKAGE BY MEANS OF A SLEEVE. THE SLEEVE SHALL BE ONE PIPE SIZE LARGER THAN THE DIAMETER OF THE PIPE PENETRATING THE WALL, AND BE SEALED WITH AN APPROPRIATE WATERPROOF SEALANT IN ACCORDANCE WITH MANUFACTURER'S GUIDELINES.
- KEYNOTES:
- A. BEDDING TO BE PLACED ON UNDISTURBED EARTH. COMPACTION OF #8 STONE IS CRITICAL UNDER ALL JOINTS AND FITTINGS. IF PROPER COMPACTION CANNOT BE ACHIEVED, THEN PLACE A MINIMUM OF 6" OF 4000 PSI, 28 DAY COMPRESSIVE STRENGTH CONCRETE AROUND THE PIPE TO BEAR ON STABLE GROUND (PER ENGINEER).
 - B. MINIMUM 4" THICK CONCRETE CAP OR VITREOUS STOPPER SEALED WITH MASTIC IS REQUIRED, NOT TO EXCEED BEYOND FIRST PIPE JOINT OF WYE. IF WYE IS 20' DEEP, THEN CONCRETE CAP IS REQUIRED AT ENGINEER'S DISCRETION. MIN. 4000 PSI, 28 DAY COMPRESSIVE STRENGTH CONCRETE REQUIRED. NOT REQUIRED FOR DUCTILE IRON TEE.
 - C. MIN. OF 8" OF STONE OVER THE CONCRETE CAPPED WYE SHALL BE PLACED PRIOR TO BACKFILL.

CITY OF BOONVILLE UTILITIES
 STANDARD DRAWINGS
 DATE: MAY 2018
 SCALE: NOT TO SCALE
 DRAWING:

Attachment A

SERVICE LATERAL
 DETAIL

CLEAN OUT REQUIRED AT ALL
 LOCATION WHERE LATERAL
 CHANGES DIRECTION.

MANUFACTURED,
 WATER TIGHT CAP FOR
 FUTURE CONNECTION
 (TYP. ALL LATERALS)

TRACER WIRE
 (TYP. ALL LATERALS)
 ONE PIECE TEE-WYE
 REQUIRED

5'-0" MIN., 8'-0" MAX. (TYP. ALL LATERALS)
 MAY NEED TO BE DEEPER FOR LONG
 BUILDINGS OR FINISHED GRADES
 SLOPING AWAY FROM SEWER

HDP E PIT WITH METAL COVER & LID
 MAINTAINED BY CITY

TRACER WIRE TEST STATION
 CLEAN OUT
 FINISHED
 GRADE
 MAINTAINED BY
 PROPERTY OWNER

GROUNDING
 ANODE (REQ'D.)
 2' MIN.,
 5' MAX.

PIPE SLEEVE
 THROUGH WALL
 (SEE NOTE 6)

WATER
 TIGHT
 SCREW
 ON CAP

22.5° or 45°
 ANGLE MUST BE
 BETWEEN 15°
 AND 45°

6" MIN.
 ANGLE MUST BE
 BETWEEN 15°
 AND 45°

22.5° or 45°
 ANGLE MUST BE
 BETWEEN 15°
 AND 45°

22.5° or 45°
 ANGLE MUST BE
 BETWEEN 15°
 AND 45°

**BOONVILLE BOARD OF WORKS
BOONVILLE CITY HALL
135 SOUTH SECOND STREETS
BOONVILLE, INDIANA**

Wednesday July 25, 2018
4:00 pm

PRESENT: Mayor Charles Wyatt, Board member, Chuck Childress, Clerk Treasurer Tammy Boruff, and Attorney Rob Phillips.

Absent: Larry Lacer

Mayor Wyatt called the meeting to order and asked all who wished to join in the Pledge to the Flag.

APPROVAL OF PREVIOUS MINUTES: Chuck Childress made a motion to approve the minutes of July 11th, 2018. Charlie Wyatt second and the motion carried 2-0.

Citizen Comments: Natalie Hyndman 723 S. 3rd St read a letter from Code Enforcement Officer Jeff Floyd regarding a safety issue involving a tree; she is requesting a 60day extension for the city to investigate further.

Chuck Childress made a motion to approve a 90 day extension from the date when the City notifies her of their findings after the city investigates. Charlie Wyatt seconded and the motion carried 2-0.

Department Reports: Fire Chief Steven Byers received 2 bids for the Fire Station.

Daryl Van Winkle Construction: \$376,500.00

Baylor: rejected \$30,500.00

Chuck Childress made a motion to take the bids under advisement. Charlie Wyatt seconded and the motion carried 2-0.

Code Enforcement Officer Jeff Floyd presented the following liens to be recorded:

Mary Miller	1317 S. 3 rd St.	\$2695.96
Terri Ness	508 E North St.	\$350.00
Audra Jo Miller & Melissa Cameron	825 S. 3 rd St.	\$350.00
George A & Doris J Kiper	717 E. Oak St.	\$350.00
Mark & Ruth Birge	1108 Chariton Dr	\$350.00
Henry & Kathy Zornes	613 E Division St.	\$350.00
Simuel W Hines	523 S. 7 th St.	\$350.00
Robert Hayden	501 N. 9 th St.	\$350.00
Beverly Kaye Stinson	712 N. 4 th St.	\$350.00
Rebecca Mehling	332 Hudspeth Ave.	\$350.00
Sharon Chase	1003 Ann Street	\$350.00
Cynthia Van Winkle	318 N. 4 th St.	\$350.00
Patsy M. Ivers	1015 Maple Ln.	\$350.00

Chief Saltzman presented bids to replace Holsters (19)

Vances: \$2052.00

Buds Police: \$2110.00

Chiefs: Supply: \$2286.50

Siegels: \$2375.00

Lawman Tactical: \$2375.00

Charlie Wyatt made a motion to purchase 19 Holsters from Vance's in the amount of \$2052.00. Chuck Childress seconded and the motion carried 2-0.

The 2 vehicles the Board of Works approved at the 7-11-18 meeting for purchase have all sold out; however Law Chevrolet found 2 more at comparable prices. The difference is \$2500.08 for the new police 2018 vehicles. Charlie Wyatt made a motion to approve the difference of \$2500.08 for the new 2018 vehicles. Chuck Childress seconded and the motion carried 2-0.

Chuck Childress made a motion to approve the Pay App #10 for Kieffer in the amount of \$222,389.90. Charlie Wyatt seconded and the motion carried 2-0.

Chuck Childress made a motion to approve invoice #15 for ME in the amount of \$8708.94. Charlie Wyatt seconded and the motion carried 2-0.

Bids for 2018 Community Crossings Project require relocation of water lines in 3 locations for Moore Street Water improvements.

Kieffer: \$85,100.00

Aigner: \$108,000.00

ISI: \$118,500.00

Chuck Childress made a motion to reject all 3 quotes. Charlie Wyatt seconded and the motion carried 2-0.

Charlie Wyatt made a motion to salvage the Vectren Electric Components from the Downtown Square Project. Chuck Childress seconded and the motion carried 2-0

Bids for Tower for Julian Lift Station for Scada:

Dieg: \$2386.00

Kieffer Bros: \$1500.00

ESM: No quote returned

Chuck Childress made a motion to approve Kieffer Bros. in the amount of \$1500.00. Charlie Wyatt seconded and the motion carried 2-0.

Chuck Childress made a motion to approve the repair of pump #2 at the Main Lift Station from Xylem Water Solutions USA, Inc. (who is a sole source vendor), in the amount of \$12,931.60. Charlie Wyatt seconded and the motion carried 2-0.

Patriot Engineer & Environmental Inc 809 E Chestnut wants permission to install soil borings in the Right of Way located on the North and South side of Taylor St.

Chuck Childress made a motion to take this under advisement so the Attorney can investigate. Charlie Wyatt seconded and the motion carried 2-0.

Chuck Childress made a motion to approve 3 utility Right of Way Permanent Easements in the back small section of sewer on west side for Wayne & Joyce Harris 1155 Eskew Rd, Wen Haili & Shaoyun Cai 1133 Eskew Rd, and Kenneth Lucas & Nina Lucas 1111 Eskew Rd. Charlie Wyatt seconded and the motion carried 2-0.

Quotes for new copiers for City Hall and Police Dept.

HBM: \$6985.00

PC Quest: \$7865.00

BMA: \$7735.00

Charlie Wyatt made a motion to approve 2 copiers to be purchased from HBM in the amount of \$6985.00 each. Chuck Childress seconded and the motion carried 2-0.

NEW BUSINESS: Bids for a new copier at the Fire Department.

HBM: \$4593.00

PC Quest: \$4995.00

BMA: \$5345.00

Charlie Wyatt made a motion to purchase a new copier for the Fire Department from HBM in the amount of \$4593.00. Chuck Childress seconded and the motion carried 2-0.

OLD BUSINESS: None

TAPS & ADJUSTMENTS:

Chuck Childress made a motion to approve a sewer tap for Lyle B Meyer 877 Julian Ct. Charlie Wyatt seconded and the motion carried 2-0.

Chuck Childress made a motion to approve a sewer tap for Joann Coleman 1255 N. Eskew Rd. Charlie Wyatt seconded and the motion carried 2-0.

Chuck Childress made a motion to approve a sewer tap for Leo Lentz 811 Julian Court. Charlie Wyatt seconded and the motion carried 2-0.

Chuck Childress made a motion to approve a sewer tap for Jerry & Edna Coleman 1166 Eskew Rd. Charlie Wyatt seconded and the motion carried 2-0.

Chuck Childress made a motion to approve a sewer tap for Michael Polk 800 N. Eskew Rd. Charlie Wyatt seconded and the motion carried 2-0.

Chuck Childress made a motion to approve a sewer tap for John Mullins 91 State Rd. 261. Charlie Wyatt seconded and the motion carried 2-0.

Chuck Childress made a motion to approve an adjustment for Cynthia Knott 1501 Autumn Dr. hidden leak in the amount of \$265.78. Charlie Wyatt seconded and the motion carried 2-0.

Coty Ritter 419 N First Street submitted a letter asking if he could attach a pipe that would direct the flow of the water from his side yard out to the sidewalk where it would be able to flow into the street and then the storm drains away from both his home and his neighbors.

Chuck Childress made a motion to deny this request. Charlie Wyatt seconded and the motion carried 2-0.

Chuck Childress made a motion to approve Dieg Brothers to move the water meters out of the sidewalk on North 4th Street while doing the Community Crossing project. The cost to remove will be for ¾" meter/pit \$1389.00 each and 1" meter \$1558.00 each. Charlie Wyatt seconded and the motion carried 2-0.

Chuck Childress made a motion to approve a 3month contract for Christopher Conner 1206 Tower Dr. Charlie Wyatt seconded and the motion carried 2-0.

Page 3
BOW 7/25/18

Shawn informed the Board that the pond by hole 17 at Quail Crossing is losing water and they are investigating the best route.

On 5-23-18 the Board approved a quote for concrete sidewalk on Edgewood Drive in the amount of \$4905.00 from CT's Concrete. Once on the job rock was needed at an additional cost of \$500.00. Chuck Childress made a motion to approve paying the additional \$500.00 to CT's Concrete for Rock on Edgewood Drive. Charles Wyatt seconded the motion and motion carried 2-0.

CLERICAL ADJUSTMENTS: Chuck Childress made a motion to approve all properly documented clerical adjustments. Charlie Wyatt seconded and the motion carried 2-0.

Page 3
BOW 7/25/18

APPROVAL OF CLAIMS: Chuck Childress made the motion to approve all properly documented claims. Charlie Wyatt seconded and the motion carried 2-0.

ADJOURNMENT: Chuck Childress made the motion to adjourn. Charlie Wyatt seconded and the motion carried 2-0.

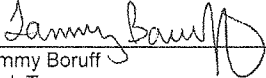

Tammy Boruff
Clerk Treasurer

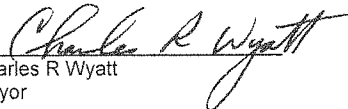

Charles R Wyatt
Mayor